

**CpE 645 Final Project**

**Practical Applications of Wavelet-based  
Multiresolution Displays**

Dec. 9, 2002

Rensheng Wang, Yu Liu

# 1 Introduction

Wavelets have been proposed in the field of signal processing due to the appealing property of representing signals compactly both in transform frequency and time domain with good resolutions and seems to promise better results with respect to conventional Fourier transforms. For classic Fourier decompositions, it can provide good frequency resolution but poor time localization. On the other hand, wavelet representations can solve this problem and decompose signals in terms of functions that are localized in both time and frequency, where the basis functions of a wavelet transform are wavelets. Wavelets usually has finite space or time duration, which can provide localized information of a signal. Moreover, wavelets are also band limited in frequency, which can represent frequency components in a signal. As a result of that, wavelet transform has received a lot of interest recently.

## 2 Wavelets and multiresolution processing

Wavelets are mathematical functions that cut up data into different frequency components, and then study each component with a resolution matched to its scale. In 1987, wavelets were first shown to be the foundation of a powerful new approach to signal processing and analysis called multiresolution theory. As its name implies, multiresolution theory is concerned with the representation and analysis of images at more than one resolution. The appeal of such an approach is obvious—features that might go undetected at one resolution may be easy to spot at another.

### 2.1 Image Pyramids Decomposition

A powerful, but conceptually simple structure for representing images at more than one resolution is the image pyramids. Each decomposition mainly consists of three sequential steps:

- Compute a reduced-resolution approximation of the input image. This is done by filtering the input and downsampling (i.e., subsampling) the filtered result by a factor of 2.
- Upsampling the output of the previous step by a factor of 2.
- Compute the difference between the prediction of Step 2. and the input to Step 1.

After decomposition, an original size image has been divided into four sub-images, where one is the low-resolution approximation sub-image and three difference sub-images. Therefore, the

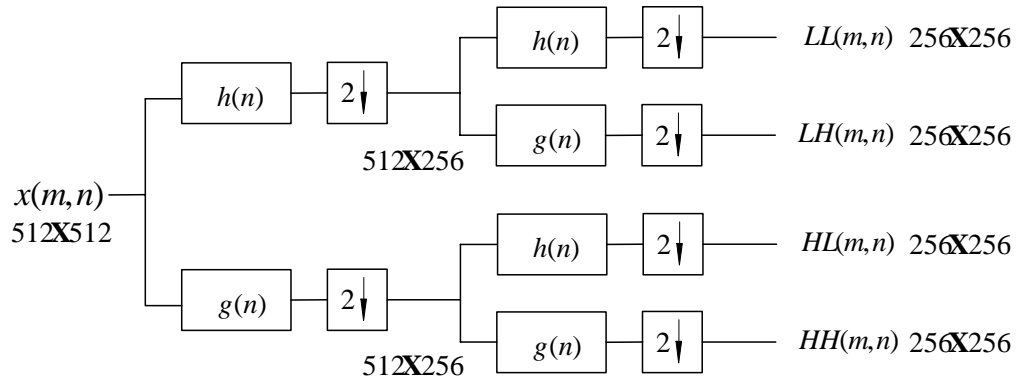

Figure 1: Image Pyramids Decomposition

difference sub-images can be coded, stored and transmitted more efficiently than the approximation sub-image.

## 2.2 Image Pyramids Reconstruction

Image pyramids reconstruction means a prediction processing from low-resolution images. During decomposition approaches, the difference sub-images can be used as prediction residual for reconstruction. Correspondingly, we need utilize the counterpart filters to rebuild the original images. In the absence of quantization error, a prediction residual pyramid can be used to generate the associated approximation pyramid, including the original image, without error.

## 3 Numerical Results

Here we choose a standard  $512 \times 512$  gray-level image with Pentagon and correspondingly, we will test a few sets of wavelet base filters as below.

- Mallat
- Laplacian
- Haar
- Second B-splide
- Third B-splide
- Biothogonal

## 4 Applications and concluding remarks

In image pyramids decompositions, one  $512 \times 512$  image has been split into four sub-banded images. The first one is a  $256 \times 256$  low-resolution approximation and the other detailed sub-images are containing the vertical, horizontal and 45 degrees edges. These direction-oriental edges are useful some oriental objects detection. Moreover, in multi-resolution decomposition, different resolution sub-images can be utilized to determine different level details. Actually, in Auto-Target Detection approach, a common way is to determine the basic and rough structure in a lower-level and refine the more accurate details in a higher resolution. This gradually steps can avoid the details confusion in an objects detection. In image compression, since the decomposed sub-image theoretically can be reconstructed without distortion, one can substitute the original image with a lower resolution sub-image, therefore, which can be stored and transmitted more efficiently. In each level decomposition, the original image can be represented by four sub-images with a equivalent total size, where the difference sub-images can be more efficiently coded, coded and transmitted. Actually, in the reconstruction approach, we can gradually recover the original image by adjusting the number of difference sub-images involved.

## 5 Matlab codes and examples

(See Appendix.)

- mywavelet.m

Main program for wavelet decomposition.

- wavelet-reconstr.m

Main program for wavelet reconstruction.

- choose-filter.m

Wavelet base filters choose function.

- grayadjust.m & reflect.m

Gray adjustment function and border image pixel reflection.