

# Game Theory for Wireless Networks

## Lecture 9

# Course outline

- Adaptive modulation for wireless networks
  - Paper on joint power control and link adaptation
  - Paper on dynamic energy minimization for wireless transceivers
- Your presentations

# Adaptive modulation

- Recall – we transmit symbols over the air by modulating a carrier

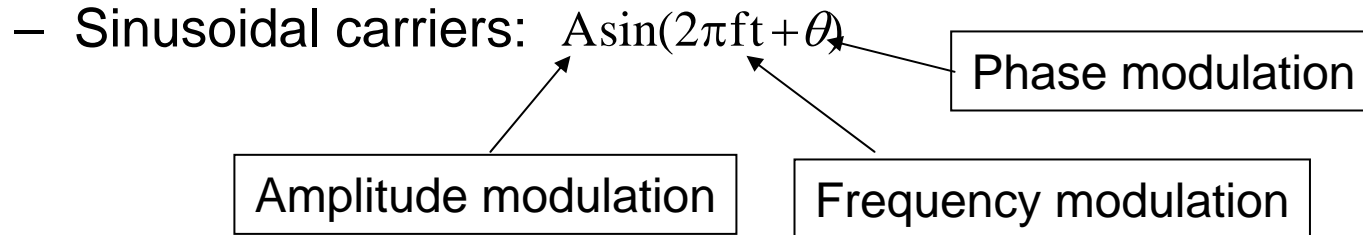

- Quadrature modulation: we use as carriers both sin and cos

- M-ary modulation:  $A_1, A_2 = \pm 1, \pm 3, \dots, \pm \sqrt{M} - 1$

- Example M - QAM

- $\log_2 M$  bits encoded into one symbol

- Large M – higher rates!!!

- **Higher BER too** → need higher SNR/SIR → better quality channel

# Adaptive modulation

- BER target  $\rightarrow$  application specific: imposed
- Channel quality fluctuates  $\rightarrow$  change modulation to meet target BER
  - Fading
  - Interference changes (burstiness, mobility, access control, etc.)
- Channel quality fluctuates  $\rightarrow$  change transmission power to achieve target BER
- Adaptive modulation and power control: related  $\rightarrow$  joint optimization??

# Joint link adaptation and power control

- Reference: “Game theoretic Analysis of Joint Link Adaptation and Distributed Power Control in GPRS”, S. Ginde, J. Neel, R. M. Buehrer, VTC, fall 2003.
- Application for GPRS
  - General Packet Radio Service → standard for wireless data communications → extension from GSM (Global System for Mobile Communications): digital cellular system, based on TDMA technology

# System model – cellular with TDMA technology

Similar as in our SIR analysis:

- First tier of interferers
- cellular reuse factor: 3

-Compute SIR in dB for user i:

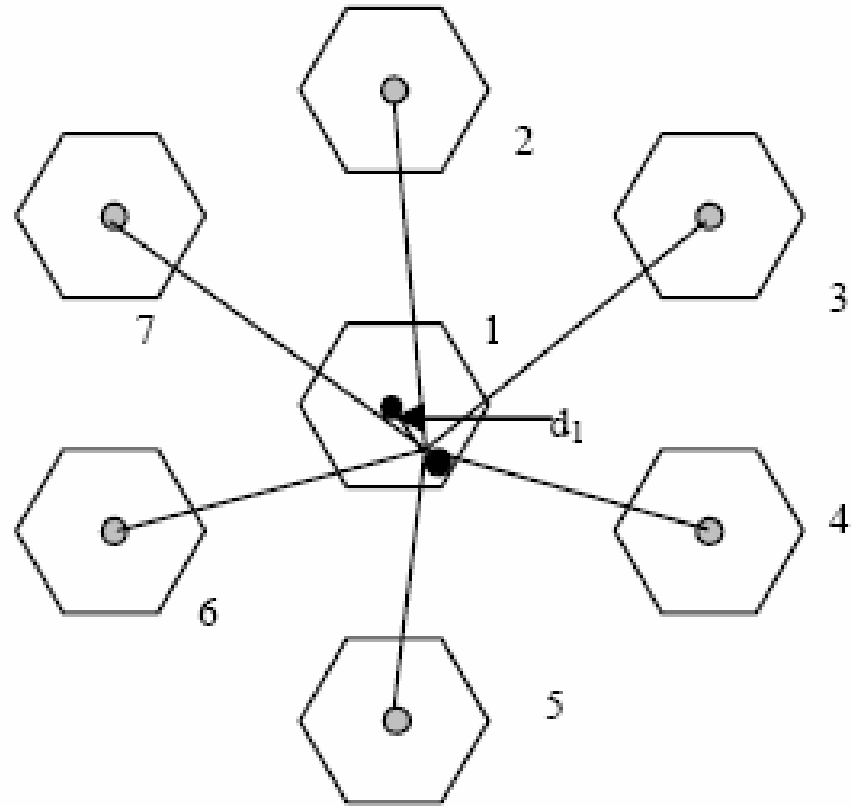

$$\text{SIR} \rightarrow \gamma_i = 10 \log_{10} \left( \frac{G_{ii} P_i}{\sum_{j \neq i} G_{ij} P_j + \eta_i} \right)$$

Transmitted Power for user j

link gain (path loss)

noise at receiver i

# Performance measure

- Performance measure: **analytical model for throughput**
  - Depends on the SNR(SIR)
  - Can be modeled by a sigmoid function of the SIR, with some parameters:  $A$ ,  $\lambda$ , and  $\delta \rightarrow$  fitted for given modulation and coding

$$L(\gamma) = \frac{A}{1 + \exp[-\lambda(\gamma - \delta)]}$$

TABLE I. GPRS CODING SCHEMES [3]

Coding Scheme	Modulation	Code Rate	Data rate/ Time slot
CS-I	GMSK	0.49	9.05 kbps
CS-II	GMSK	0.64	13.4 kbps
CS-III	GMSK	0.73	15.6 kbps
CS-IV	GMSK	1	21.4kbps

# Performance measure: Throughput

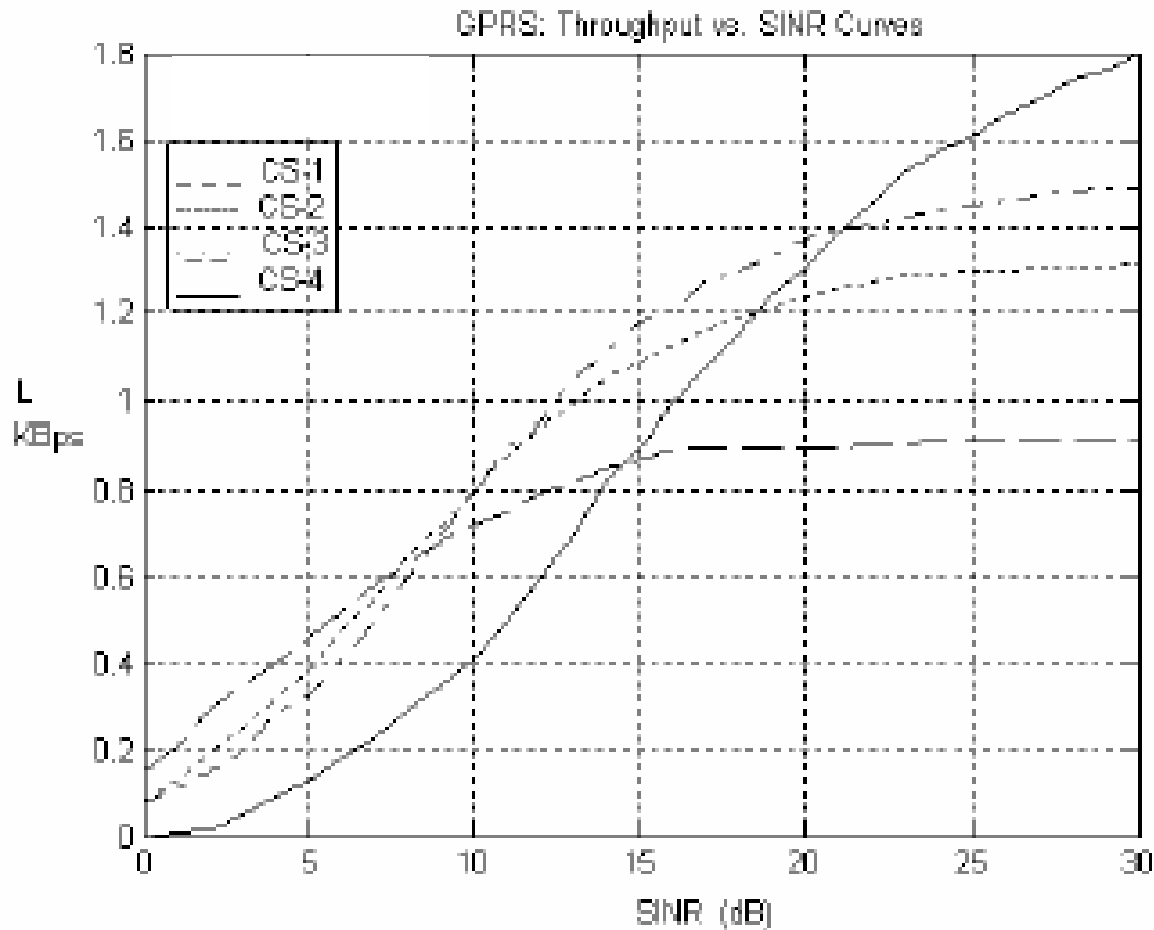

CS	A kbps	$\lambda$	$\delta$ dB
CS-1	7.36	0.272	4.75
CS-2	10.52	0.256	8.250
CS-3	11.88	0.256	9.5
CS-4	14.36	0.231	15

# Game theoretic formulation

- Players: set of co-channel links
- Actions: select powers and rates:

$$A_i = \{(P_i, r_i) \mid P_i \in [P_{i,\min}, P_{i,\max}], r_i \in \{r_1, r_2, r_3, r_4\}\}$$

- Utility function: throughput measure with pricing function

$$U_i(\mathbf{P}, r_i) = \frac{A(r_i)}{1 + \exp\{-\lambda(r_i)[\gamma_i - \delta(r_i)]\}} - KP_i^q$$

# Existence of Nash equilibrium

- If keep rates constant (select only powers)  $\rightarrow$  Debreu's theorem holds  $\rightarrow$  guaranteed to have at least 1 Nash equilibrium

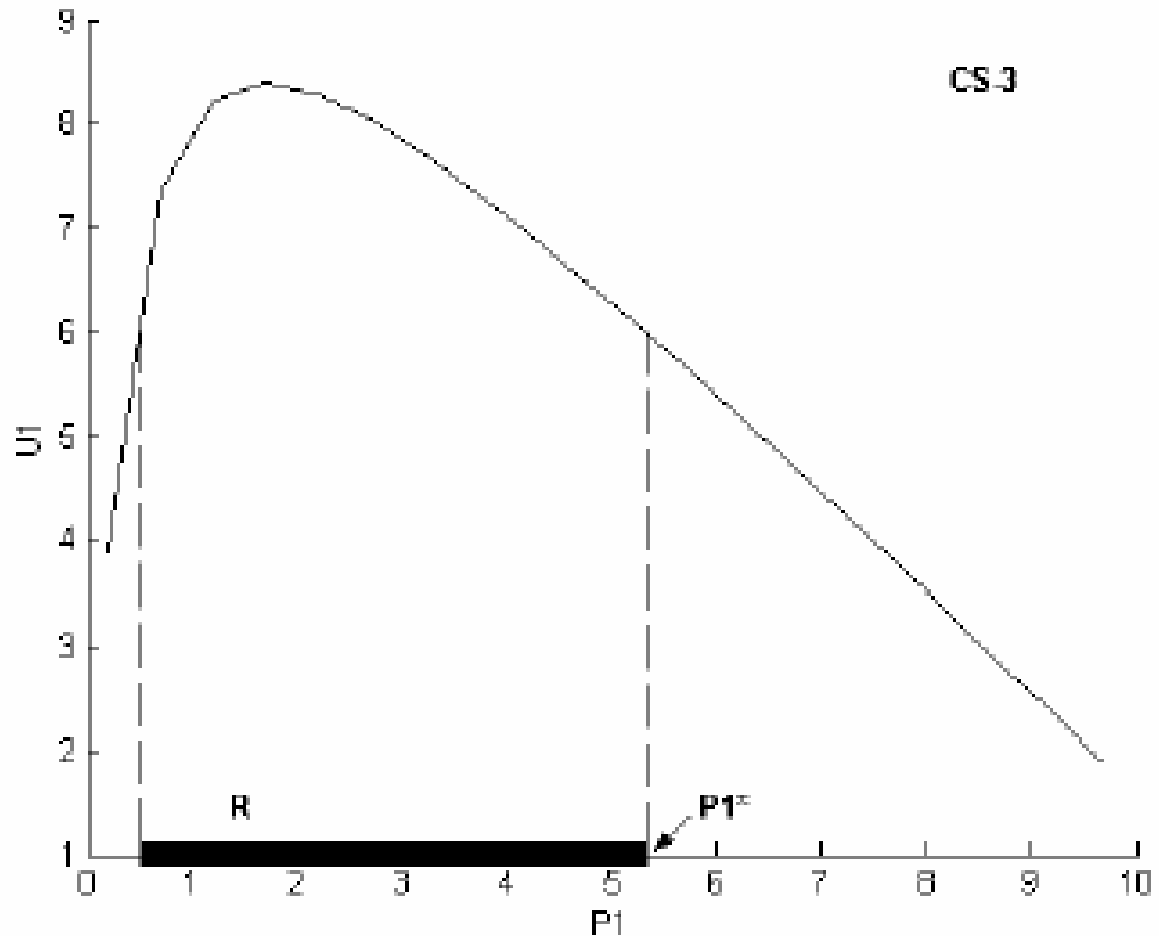

# Joint power control and rate assignment solution

- Two step optimization:
  - start with some initial values for powers and rates
  - Step1: select power to maximize utility function

$$P_{i,eqm} = \max_{P_i} U_i(P_i, P_{-i}, r_i)$$

- Step 2: for the given selected powers, determine rates

$$r_{i,eqm} = \arg \max_{r_i} U_i(r_i, \mathbf{P}_{eqm})$$

- Continue until no improvement in rates can be achieved

# Figures of merit definition

- **FOM1:** ratio between system throughput and sum of the fractions of peak power consumed by links

$$FOM1 = \frac{\sum_i L_i}{\sum_i \frac{P_i}{P_{\max}}}$$

- **FOM2:** difference between system throughput and sum of the fractions of peak power consumed by links, scaled by the peak throughput

$$FOM2 = \sum_i L_i - A_{\max} \sum_i \frac{P_i}{P_{\max}}$$

- **FOM3:** system throughput

$$FOM3 = \sum_i L_i$$

# Nash equilibrium: not unique

$K=1$ ,  $q=2$ , SNR = 100dB

Histogram plot of FOM 1

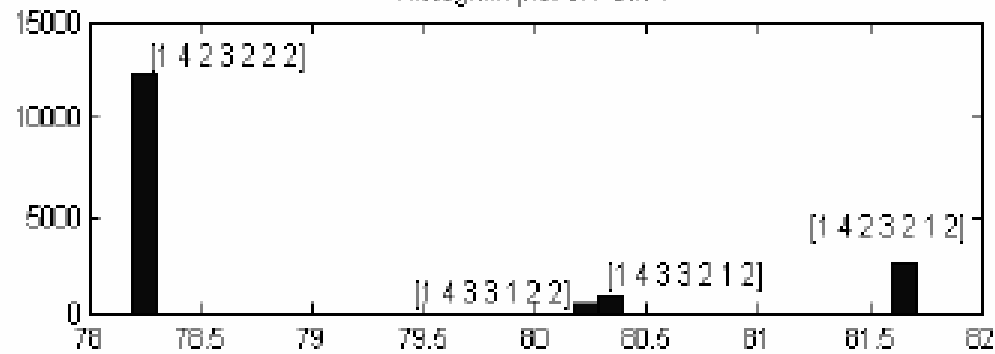

Histogram plot of FOM2

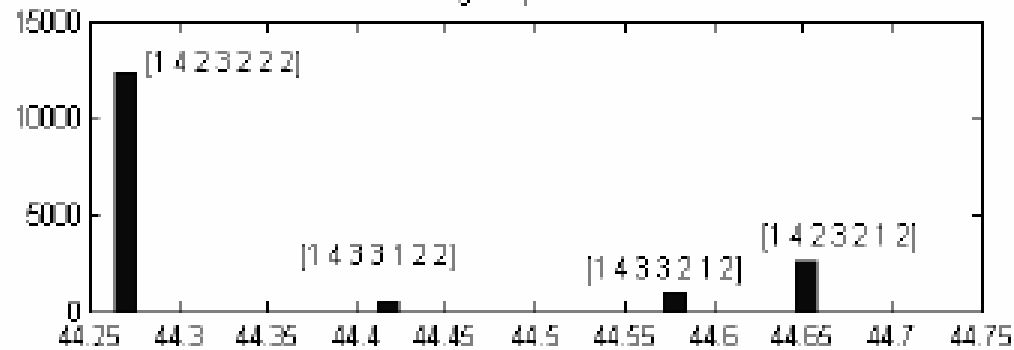

Histogram plot of FOM3 = Sum of throughputs

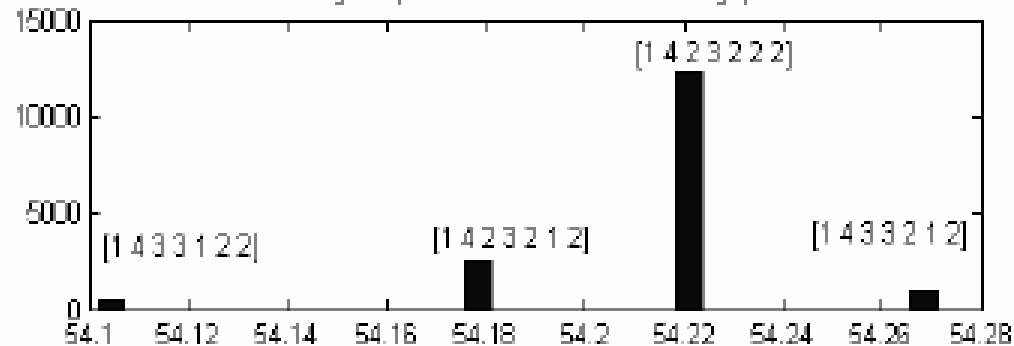

# Some performance results

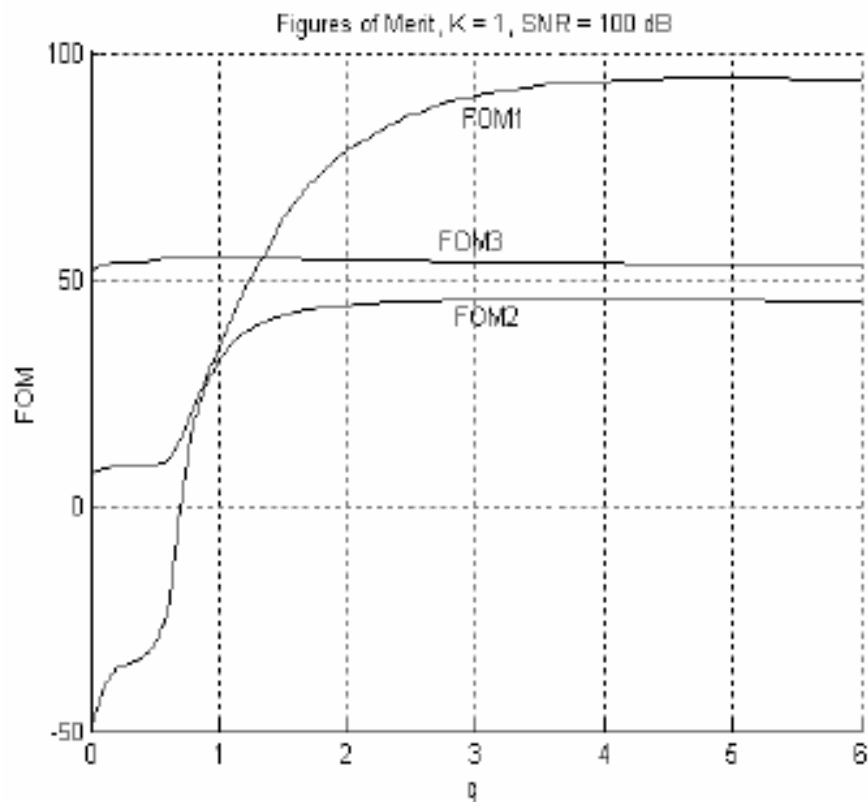

Figure 5. Effect of  $q$  on FOM's, SNR = 100 dB

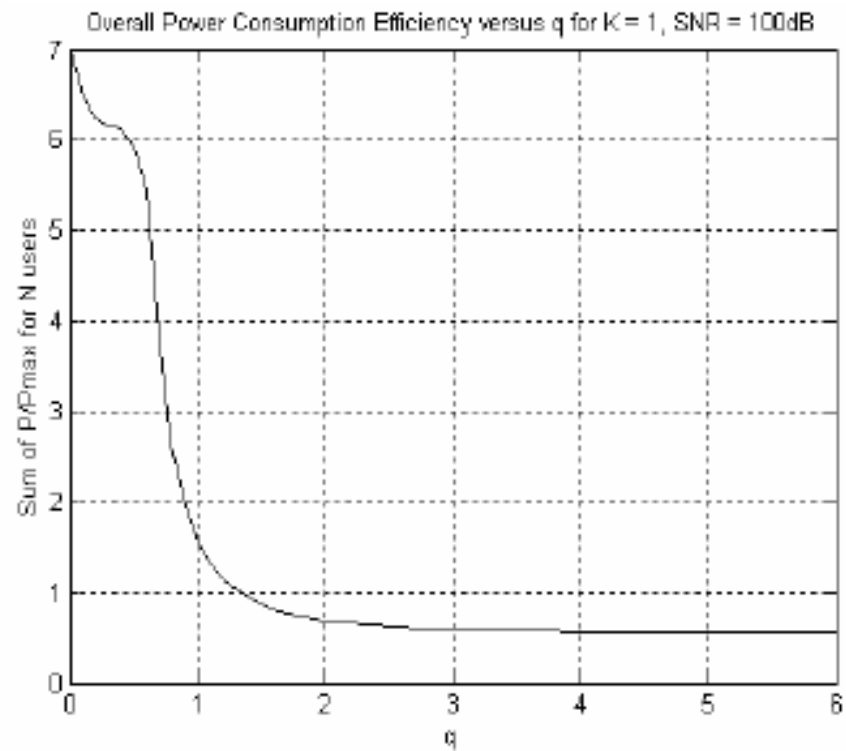

Figure 6. Effect on  $q$  on power consumption

# More performance results

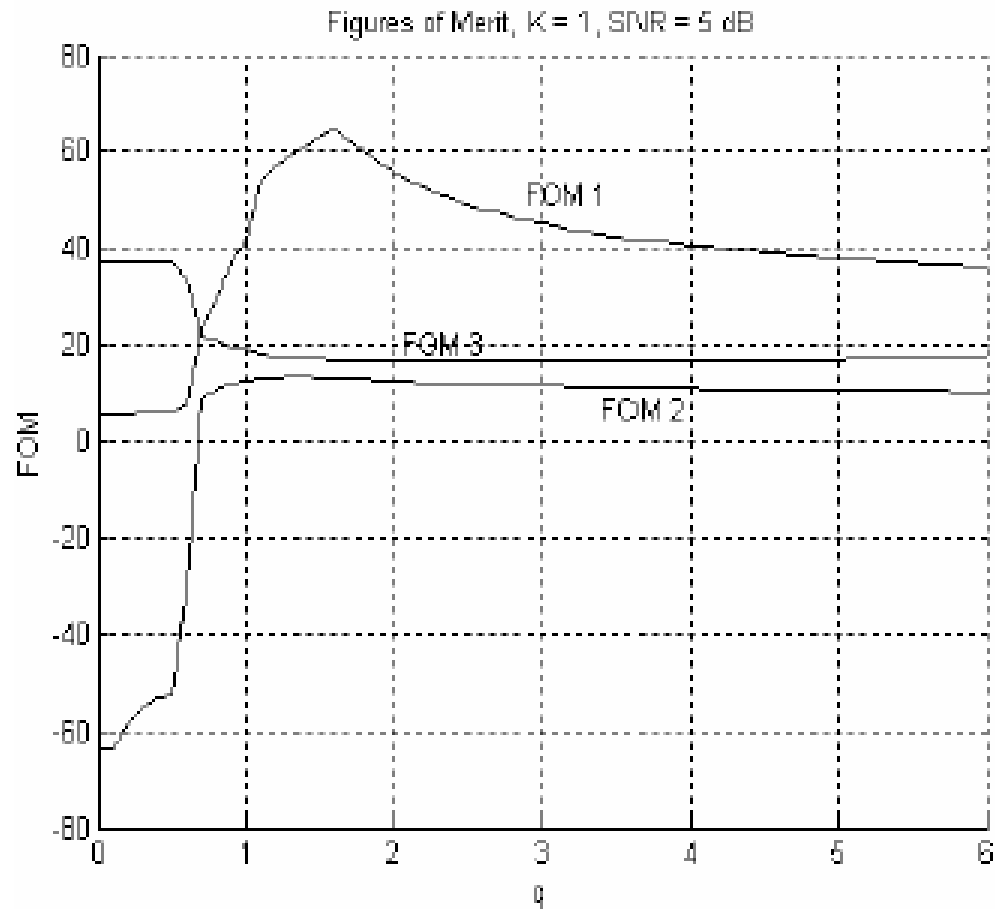

Figure 7. Effect of  $q$  on FOM's, SNR = 5 dB

# Dynamic energy minimization in wireless transceivers

- Reference: “A Game Theoretic Approach to Dynamic Energy Minimization in Wireless Transceivers”, A. Iranli, H. Fatemi, M. Pedram, Int’l Conference on Computer Aided Design, November 2003, pp. 504-509.
- System model: ad hoc network, OFDM (Orthogonal Frequency Division Multiplexing) transmission (802.11a)
  - OFDM = multicarrier transmission technique, which allows a more tight packing of multiple carrier frequencies, by keeping the carriers orthogonal
  - A signal is split into sub-signals that are transmitted in parallel on the multiple carriers

# Optimization problem

- Minimize total energy consumption for a link
  - (A) Minimize energy at transmitter
  - (B) Minimize energy at receiver

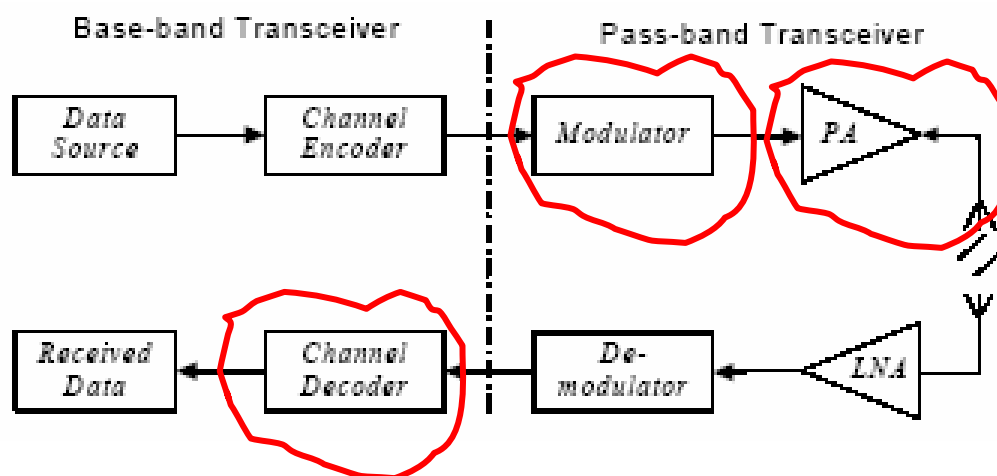

# Optimization problem

- No interference is considered
- Transmitter: can select powers and modulation levels → influences the total energy expenditure
- Receiver: can choose decoder's parameters:
  - For convolutional codes → Adaptive Viterbi decoder → accuracy of decoder increases as the number of decoding stages increases; however, the power consumption of the decoder increases also
  - Parameters chosen: Truncation length (number of paths consider to find the optimum path) of the decoder
- Receiver and transmitter alone cannot optimize energy independently, depend one of another
- Optimization modeled as a Stackelberg game → multi-level optimization problem formulated

# Optimization problem

- Strategy for the receiver:  $x \in X$

$$X = \{(TL_1, TL_2, \dots, TL_n \mid \forall i : TL_i \in TLS)\}$$

- Strategy for transmitter:  $y \in Y$

$$Y = \{P_{Tx}, b_1, b_2, \dots, b_n \mid i : b_i \in MLS, P_{Tx} \in PLS\}$$

- Optimization:

$$\{(\hat{X}, \hat{Y}) \mid A\hat{X} + B\hat{Y} < R\hat{E}Q_{Tx}, D\hat{Y} \geq R\hat{E}Q_{Tx}, \hat{X}, \hat{Y} \geq 0\}$$

Coef. Matrices – account for channel characteristics

Vector  $\rightarrow$  upper bound on overall Energy consumption

Coef. Matrix for linear est. of throughput and BER, in terms of SNR and mod. level

# Some performance results

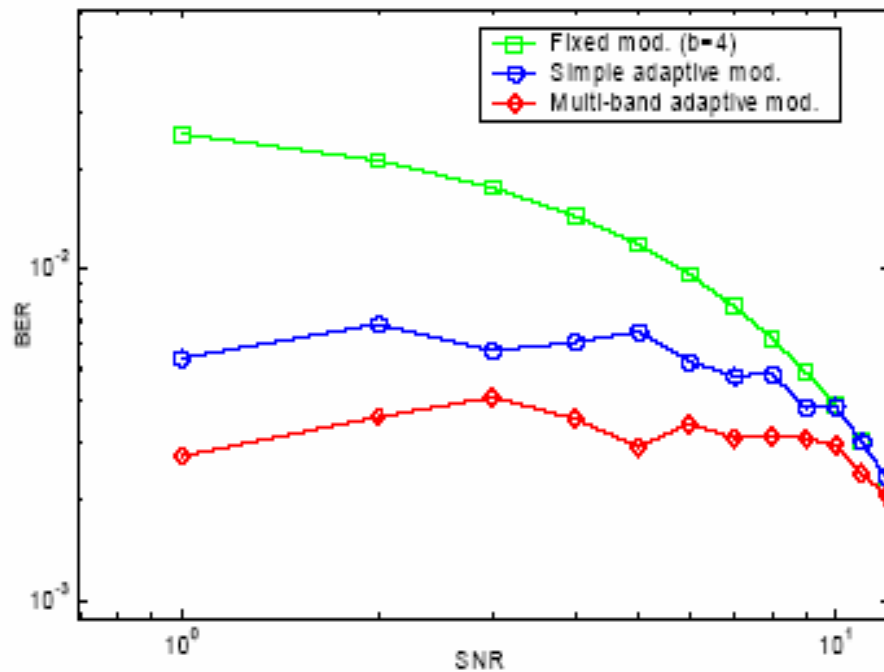
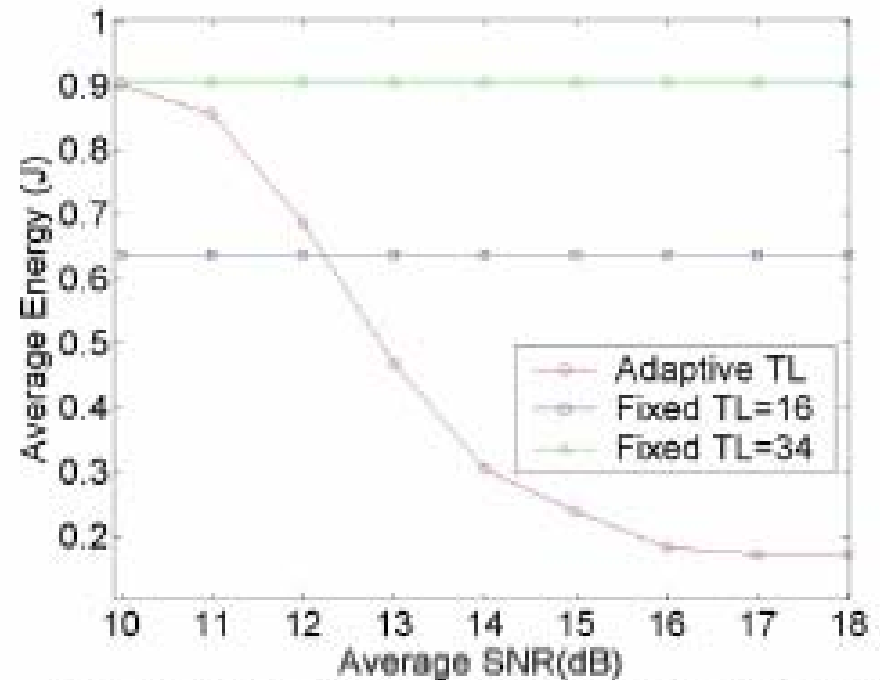

Figure 5. Average BER as a function of SNR for adaptive and fixed modulations



(a) Average Energy vs. SNR ( $BER=10^{-4}$  &  $b=4$ )

# More performance results

$$E_{avg} = \alpha \cdot E_{Transmit} + (1 - \alpha) \cdot E_{Receive}$$

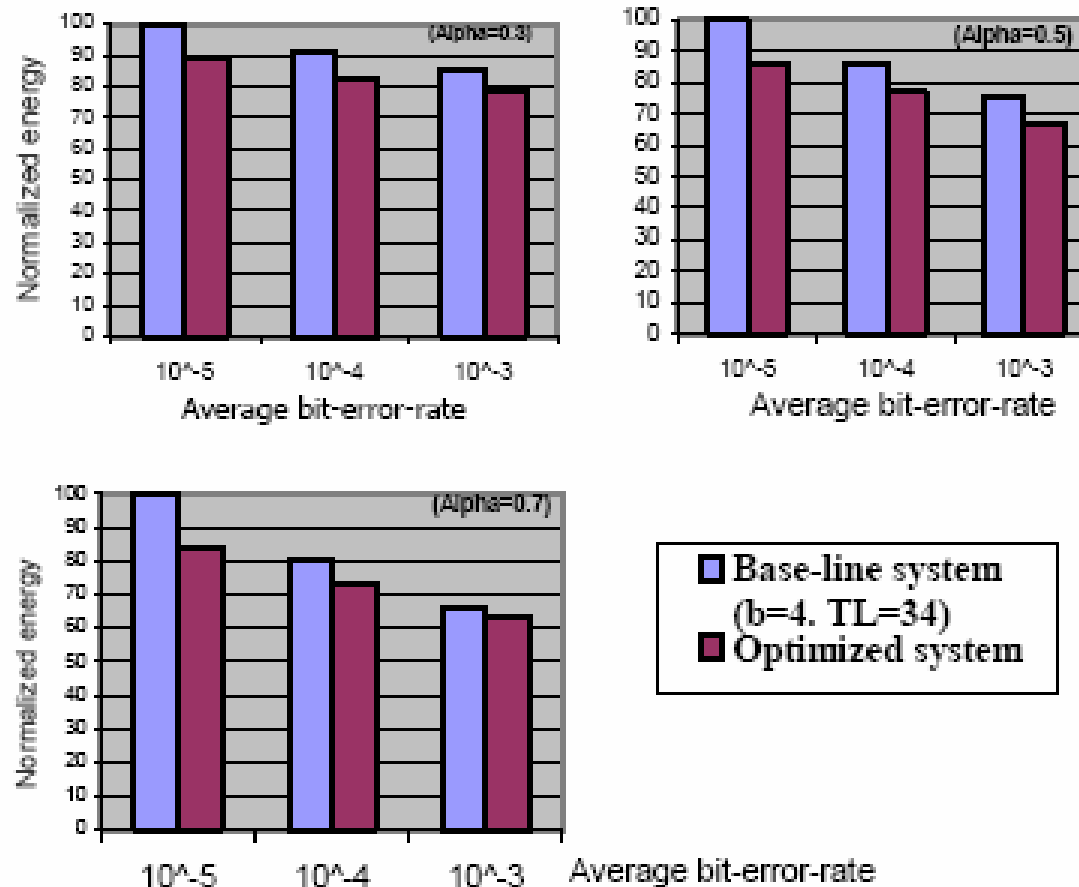

Figure 7. Normalized energy consumptions