

What To Do When the Plan Doesn't Work

Or

Everything You Need To Know Is Contained In a Few Nuggets

Prof. Barry Bunin
Sept. 18, 2007

The Paradigm

- 95% of everything you learn, you will forget after finals

So...

- Look for the Nuggets
(P.S. This is the first Nugget)

Nuggets



Evolution of Wireless Technology

- Wireless voice began as Broadcast/ Entertainment radio (still called wireless in some places), with fixed, inexpensive User Equipment (UE), i.e. table radios
- Mobile, one-way, entertainment radio began in the 1930's with radios in motor cars (By a company that called itself *Motorola*, which is still doing OK)

1924



Evolution of Mobile Telephony

- Two-way mobile radio-*telephony* began during WW II, with Push-to-Talk Walkie-Talkies (Push-to-Talk is now re-emerging as a hot new service)
- Now, mobile radio-telephony is a “killer technology”, meaning that it has changed the way we live and work
- But what initiatives are underway to drive continued growth?

What's the Buzz?

Next Generation Internet



Next Generation Switching Explored

Tom Vandewater
Regional Manager
(510) 748-8239

THE
**INTERNET
TELEPHONY
CONFERENCE & EXPO**

The #1 Global Event On Voice, Video,
Fax, And Data Convergence.

Celebrating Our 5th Year!

**October 14-16 2003
Long Beach California
The Westin Long Beach Hotel**

Motorola Introduces **Next-Generation** Cellular Base Station RF Technology

Sixth Generation RF LDMOS Technology Sets Industry Standards with Higher Performance and Efficiency

CTIA WIRELESS 2003, NEW ORLEANS - March 17, 2003 - Motorola, Inc. (NYSE:MOT) is introducing its sixth generation of

amplifiers. Motorola offers equipment designers in the digital network arena a vital portfolio of high power RF LDMOS (laterally diffused metal oxide semiconductor) transistors to help develop low cost, highly efficient cellular base stations for voice, data and video transmissions.

First Generation Cellular Systems

Advanced Mobile Phone Service-AMPS

- Prior to cellular systems, when a mobile phone used a channel centered on a certain frequency, that channel could not be reused in the area without causing interference
- This limited the number of users and the QoS (Quality of Service) due to noise and interference

Cellular vs. Non-Cellular Networks

Analog Example

Improved Mobile Telephone Service

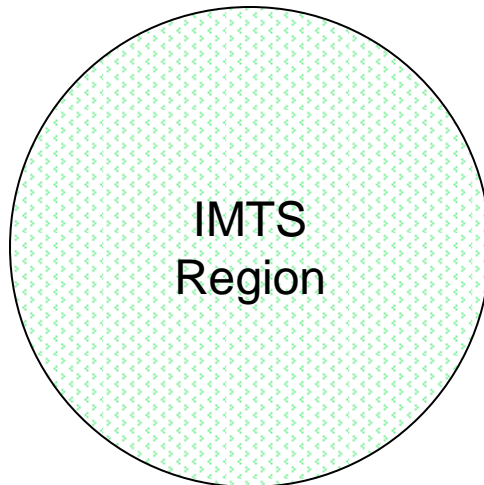

Spectrum Allocation: 50 MHz
(25 MHz Uplink; 25MHz Downlink)

Channelization: 30 kHz/Analog
Full Duplex Channels

Total Channels: 832

A Cellular Layout Using 7 Cells

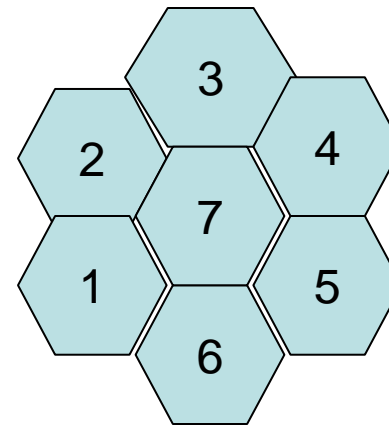

Spectrum Allocation per Cell:
 $1/7 * (25 \text{ MHz})$

Channelization: 30 kHz

Channels/Cell: 119

Total Channels: 832

Cellular Evolution

- **Major** technological innovations in Cellular (as well as other) technologies are referred to as “generations”
- First generation (1G) is Advanced Mobile Telephony Service (AMPS)

Cellular Evolution

2G Digital

- Second Generation (2G) brought digital technology
- Two major systems: Digital AMPS and GSM (Global System for Mobile Telephony)
- Channels created using Time-Division Multiple Access
 - Time slots are created within the frequency division channels, and are contended for by the mobile users

GSM

Global System for Mobile Communication

- Most popular 2G technology
- Built to maximize “Roaming” capability, especially in Europe
- Used Subscriber Identity Module (SIM) card
 - Enables easily changed/upgraded cell phone
 - Enables easily changed service provider
 - Contains subscriber identification, authentication keys, etc
 - Standardization of SIM (and other system parameters) maximizes roaming
- Short Message Service (SMS) demonstrated the market for data services in the cell phone environment

The Drive to 3G

- Market demands for higher data rates for web access, e-mail
- GSM limits of 9.6 kb/s, worse than dial-up modems, and uses lots of expensive minutes
- **Service providers need new revenue sources**
- **Equipment vendors need something to sell!**
- But Service Providers who paid 100's of millions for 2G spectrum and networks sought interim solutions – General Packet Radio Service

Generic Architecture

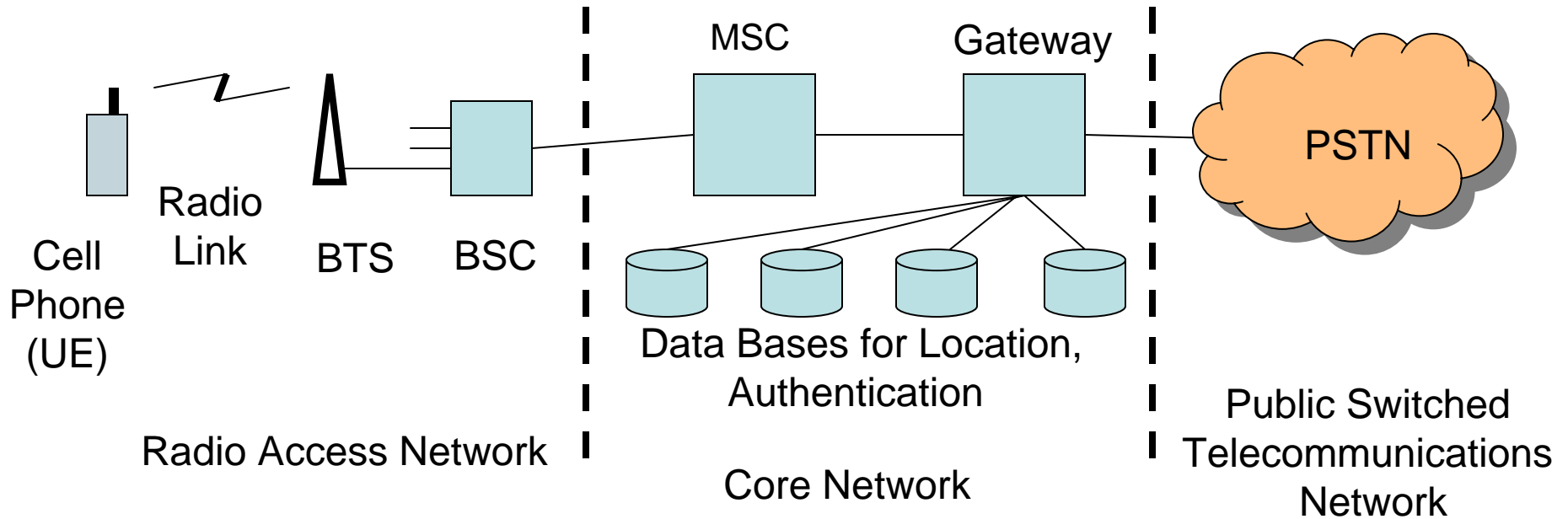

- A cellular network is comprised of a **Radio Access Network**, a **Core Network** (for handover, roaming, PSTN access), and a set of **Data Bases**
- Evolutionary innovations are made in all these areas

The Generation Gap

Evolution to 3G

- A partial taxonomy:

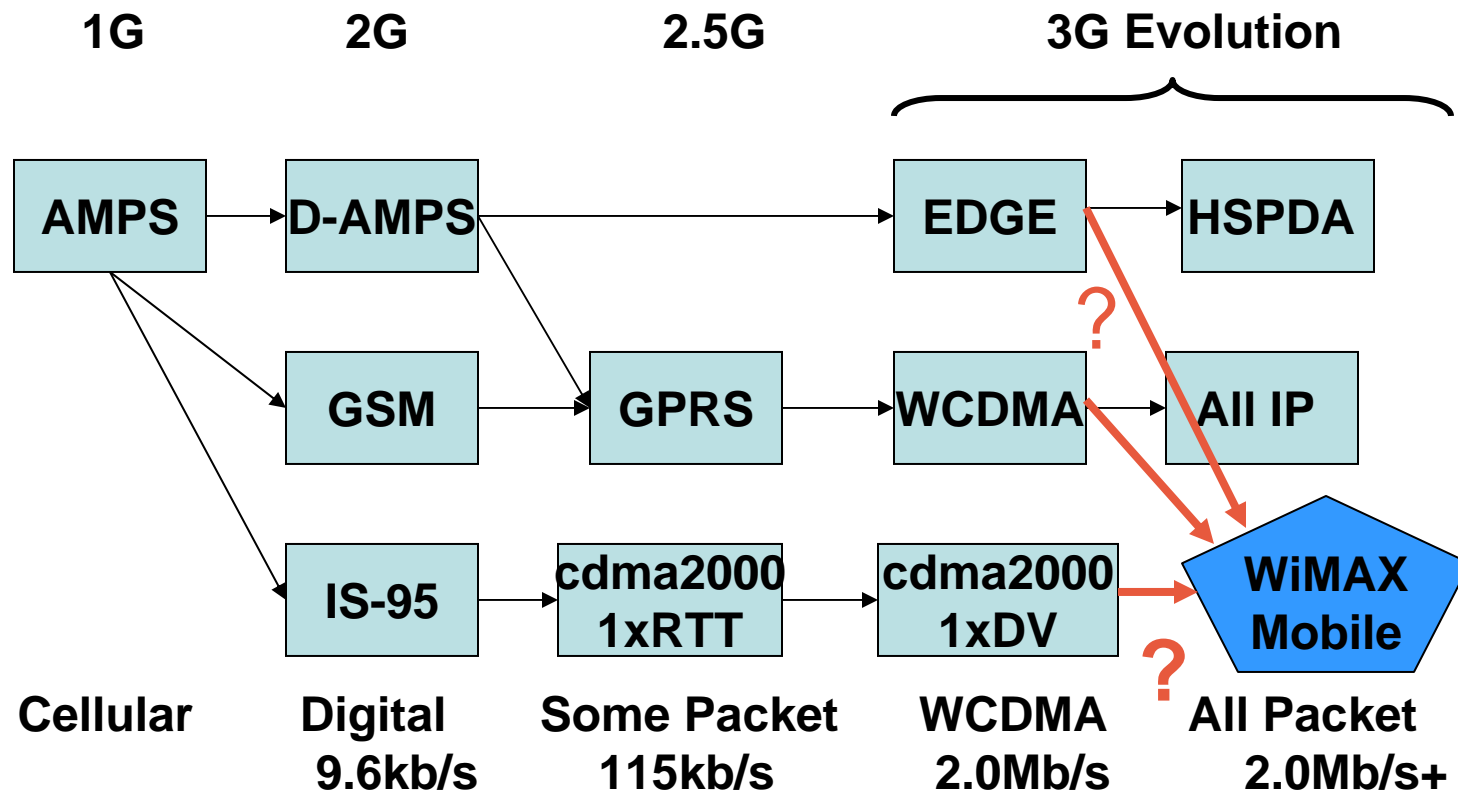

Should Your Company Build The Next Generation Technology?

Should Your Company Build The Next Generation Technology?

- It depends on where you are!

Some Nuggets, maybe...

- Look for some nuggets!
- Don't trust the next generation
- Is the next generation really the next generation (or is it only an increment)?
- Before making a big decision, remember you might have to live with it
- A good decision depends on where you are starting from