

Real-Time Embedded Systems

CpE-450 Spring 07

Class 12

Bruce McNair

bmcnair@stevens.edu

Case Study 3: The Cellular Phone

~1994 600 mW
Analog AMPS



~1996 600 mW
AMPS/TDMA



~2001 600 mW
AMPS/TDMA



~1990 3W
Analog AMPS

Case Study 4: The Cellular Phone



Transceiver Anatomy 101



Transceiver Anatomy 102



Lessons from Anatomy

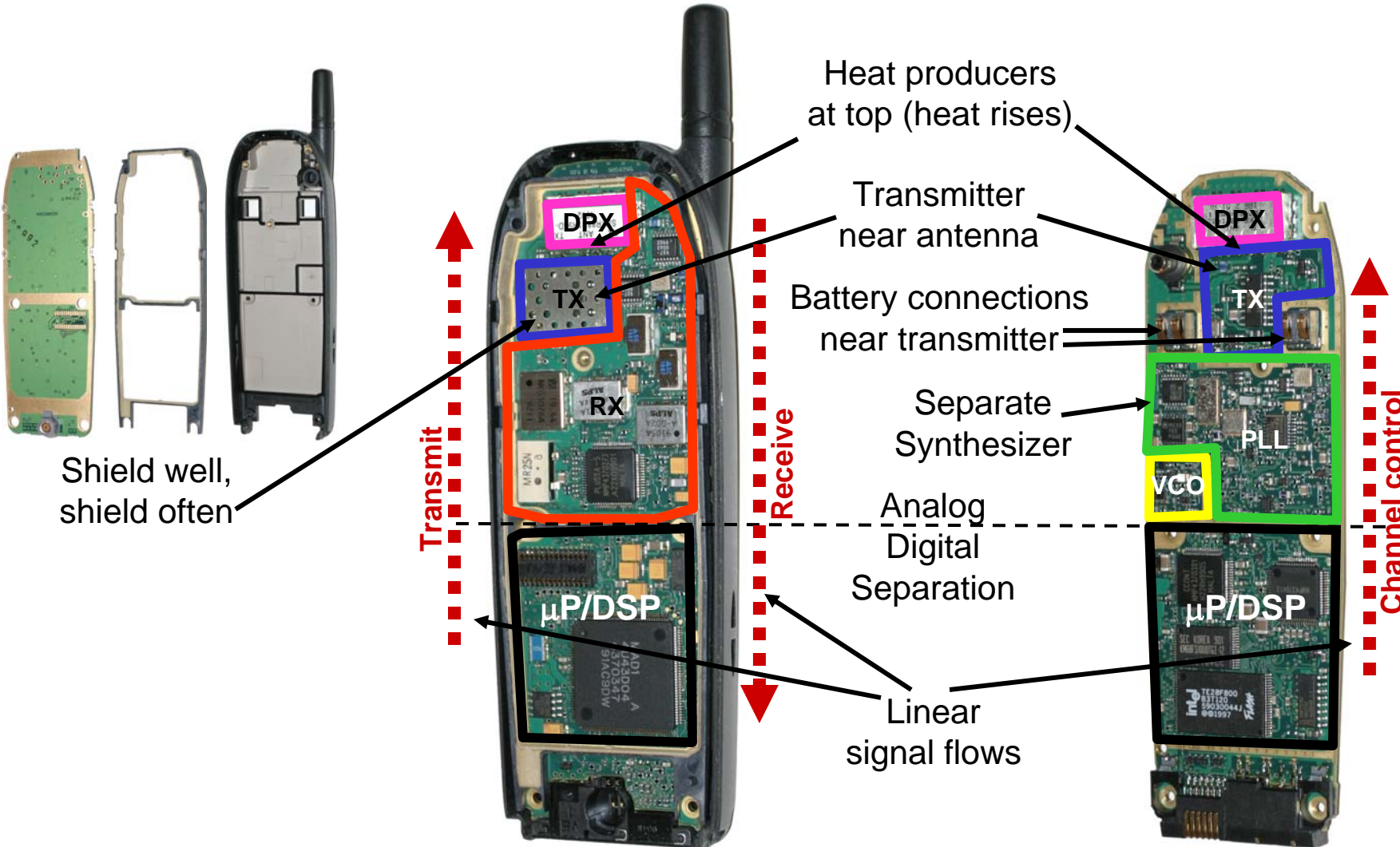

Clock Generation

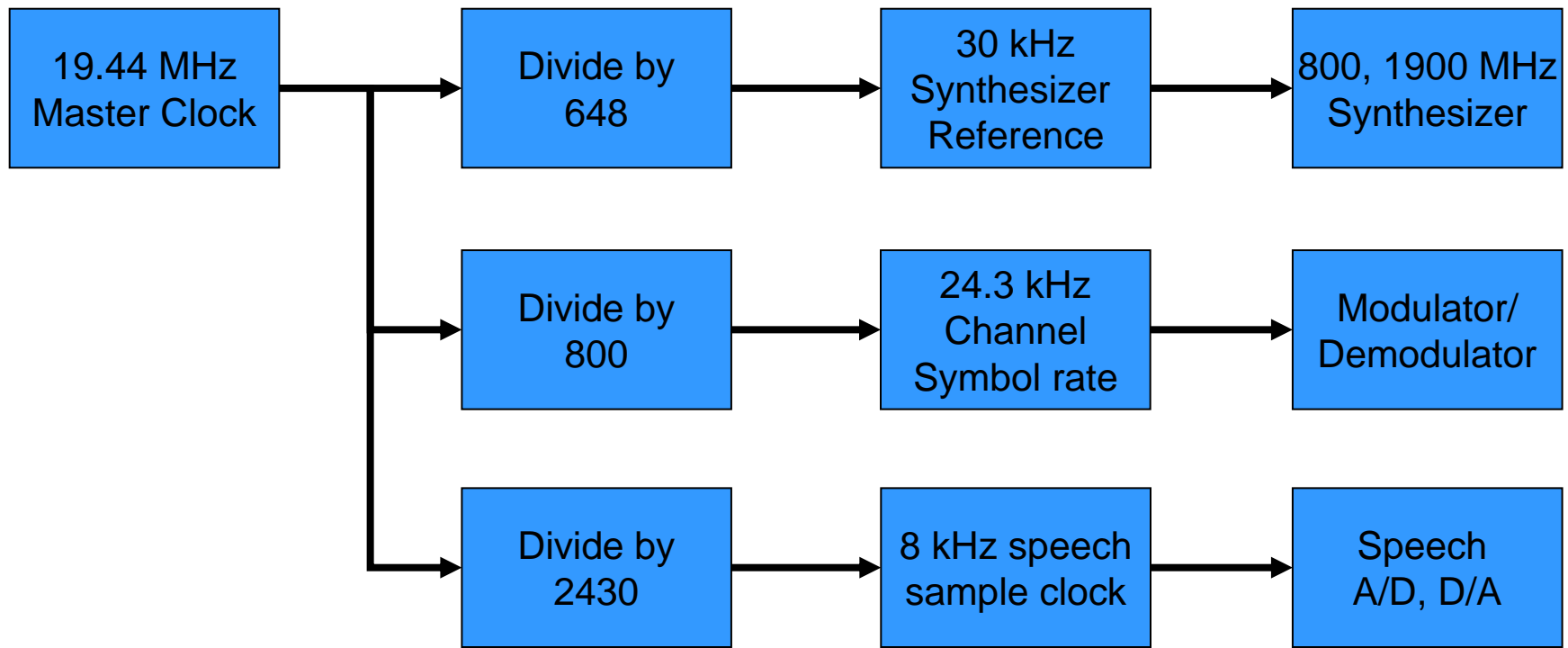

IS-136 Channel Structure (Downlink)

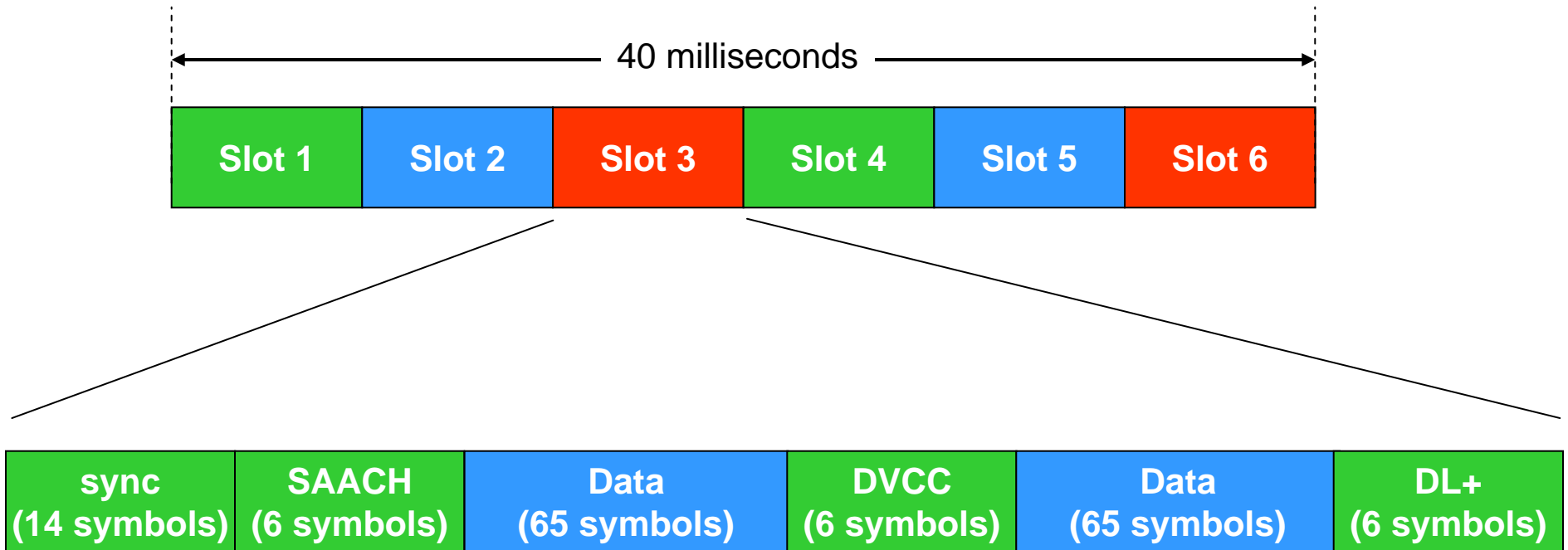

$(162 \text{ symbols/slot} * 2 \text{ bits/symbol}) * 6 \text{ slots/frame} \rightarrow 1944 \text{ bits/frame}$

$1944 \text{ bits/frame} * 25 \text{ frames/sec} \rightarrow 48.6 \text{ kb/s}$

IS-136 Channel Structure (Downlink)

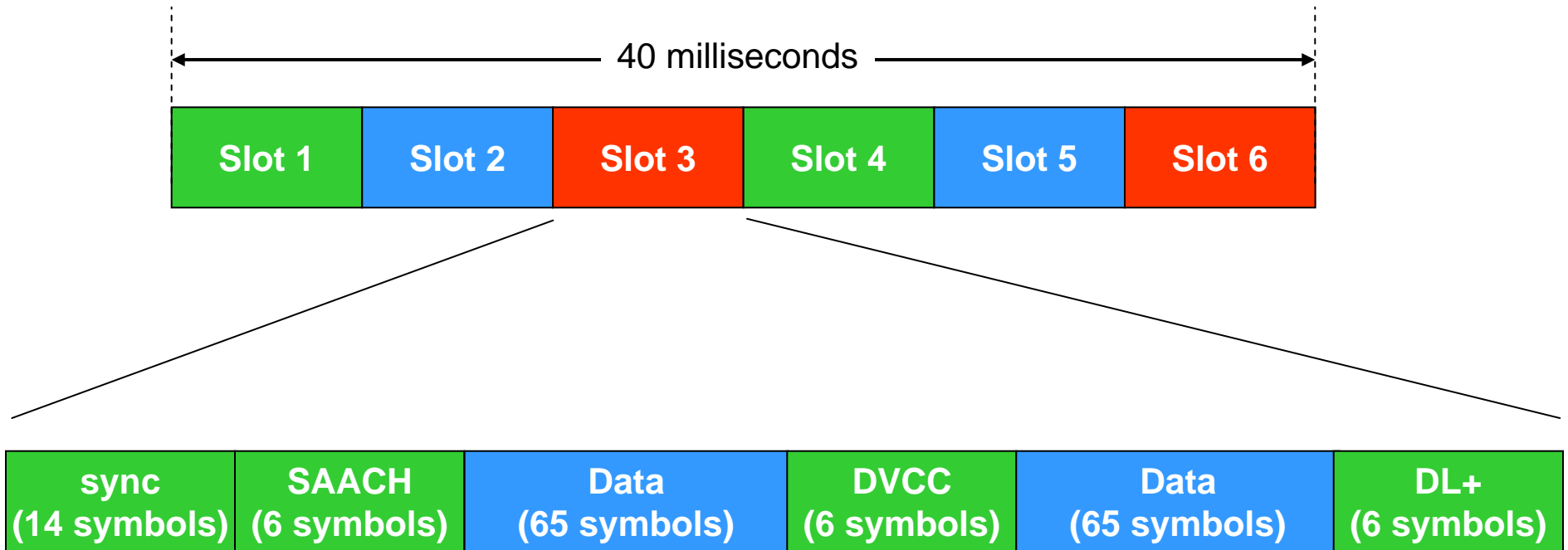

$(130 \text{ data symbols/slot} * 2 \text{ bits/symbol}) * 2 \text{ slots/frame} \rightarrow 520 \text{ data bits/frame}$

$520 \text{ data bits/frame} * 25 \text{ frames/sec} \rightarrow 13 \text{ kb/s (data)}$

IS-136 Transmitter/Receiver Structure

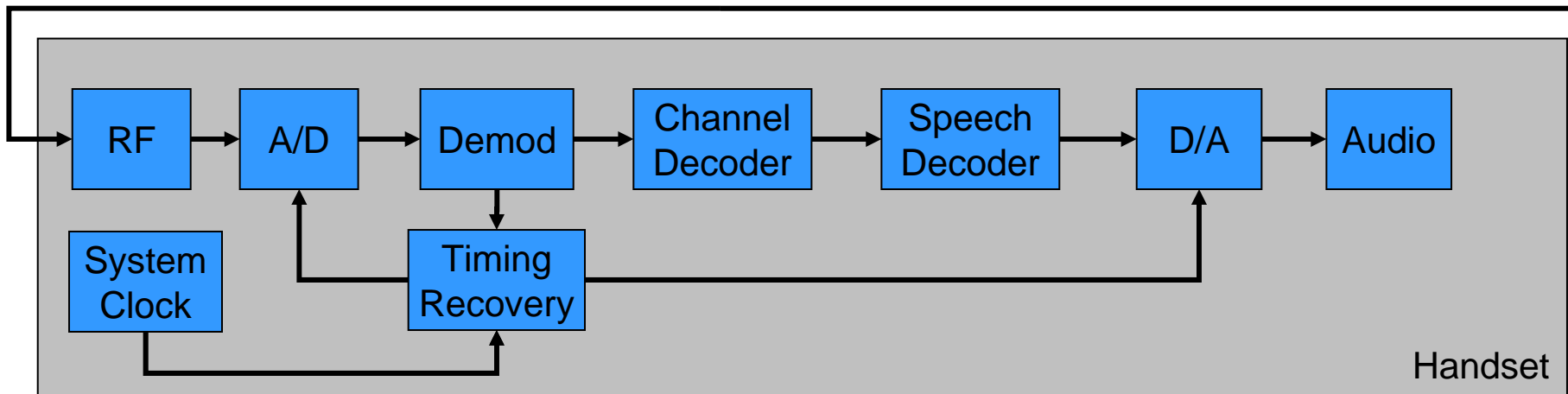
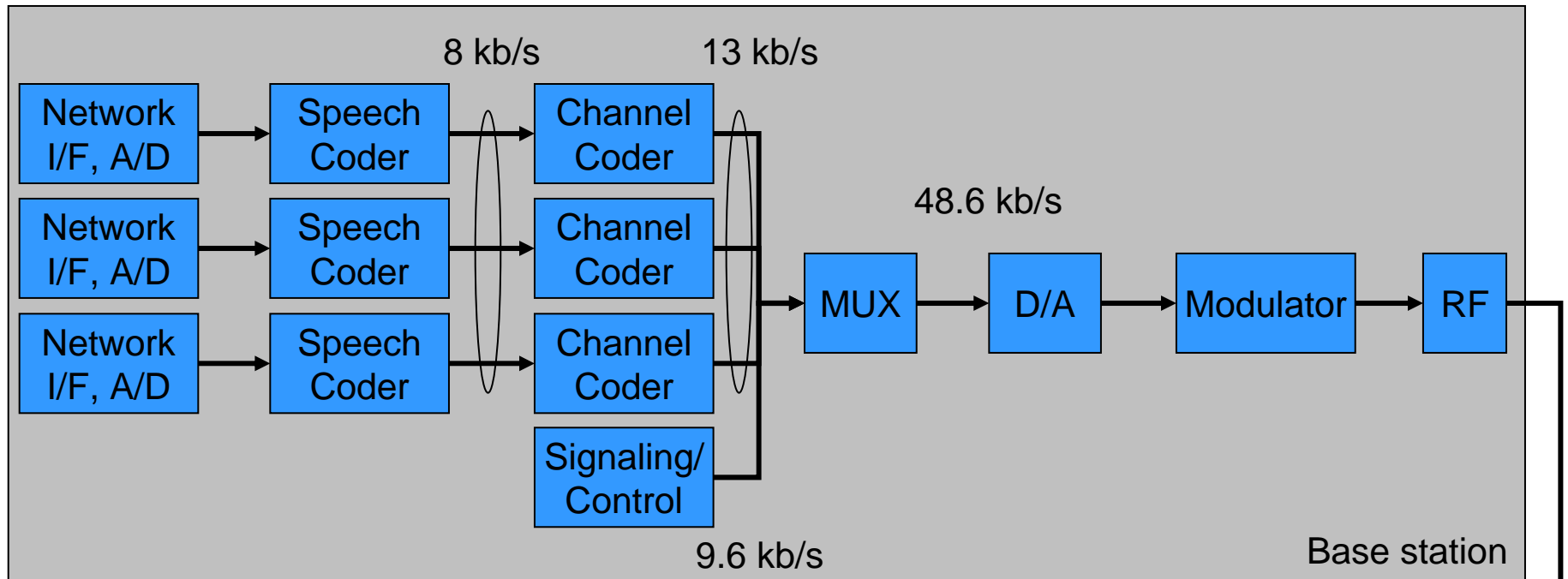

Handset Receiver Software Structure

```
main()
{
initialize();
while(1)
{
sleep();
switch(alarm)
{
case 40ms:
demod_frame(!FB#);
decode_frame(!FB#);
if(detect_signal(!FB#))
act_on_sig();
adjust_timing();
decode_speech(!FB#, !SB#, P);
break;
case user:
x=decode_command(UIB);
act_on_command(x);
break;
}
}
}
```

Interrupt on IS-136 frame

Interrupt at 8 kHz

Interrupt on user input

```
bit frame_buffer_nr=0;

40ms_frame_int()
{
read_a_frame(frame_buffer_nr++);
wake_BG(40ms);
}
```

```
bit speech_buffer_nr=0;
int position;

speech_DA_int()
{
write_DA(speech_buffer_nr, position);
if(position>length)
{
SB#++;
position=0;
}
}
```

```
char UI_buffer_nr[N];

user_int()
{
scan_UI(UI_buffer_nr++);
wake_BG(user);
}
```

Timing adjustment

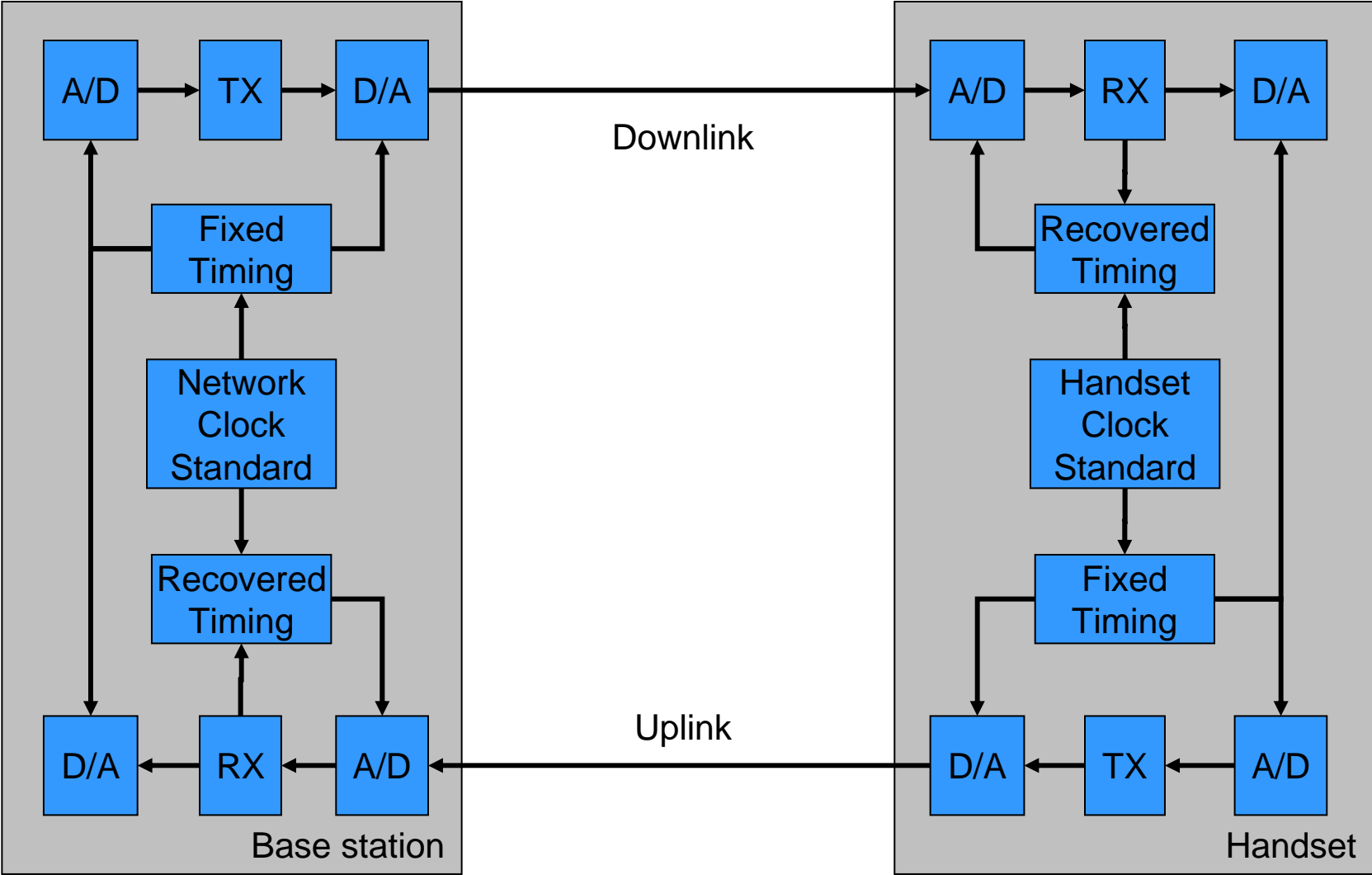

Timing adjustment

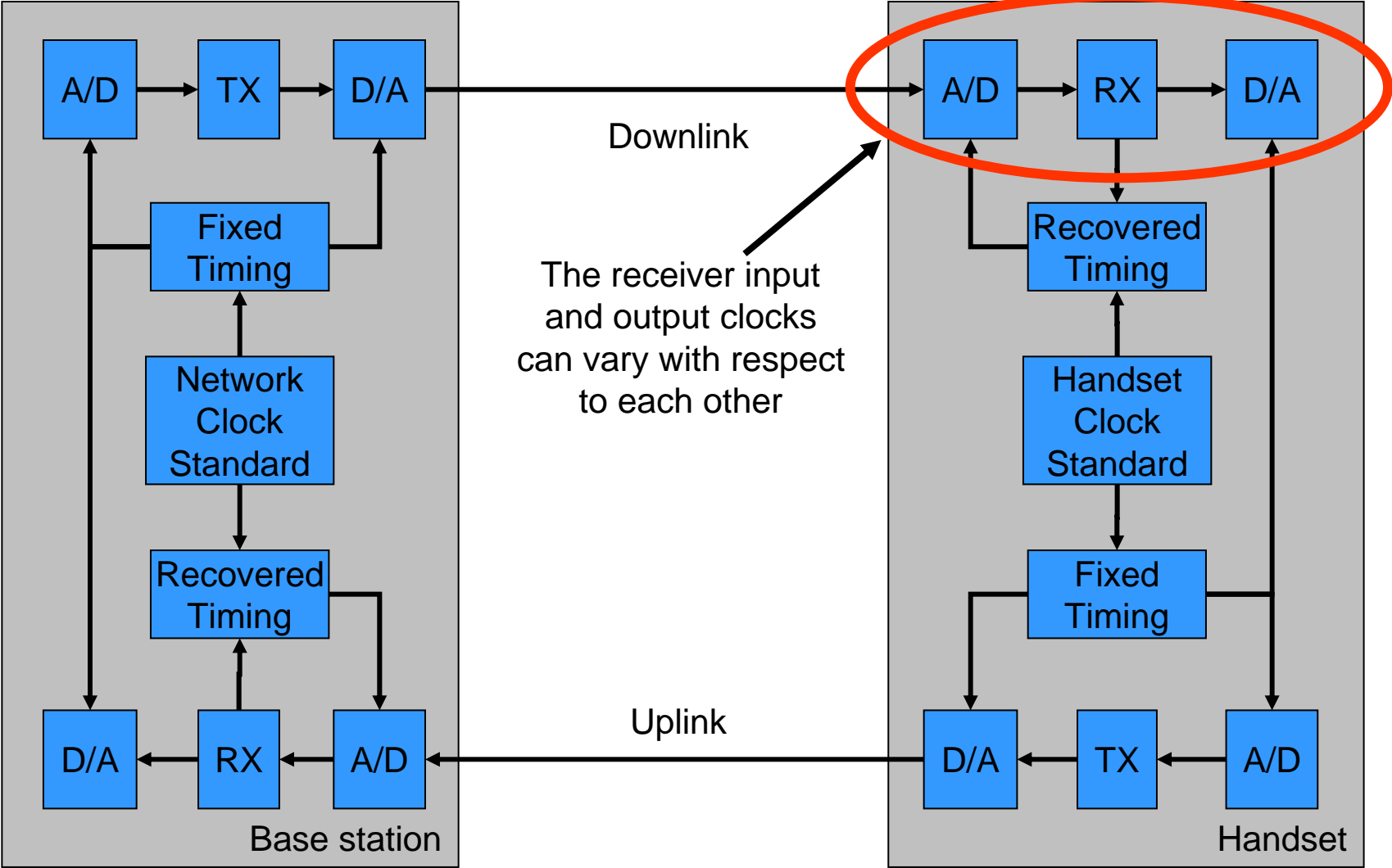

Timing adjustment

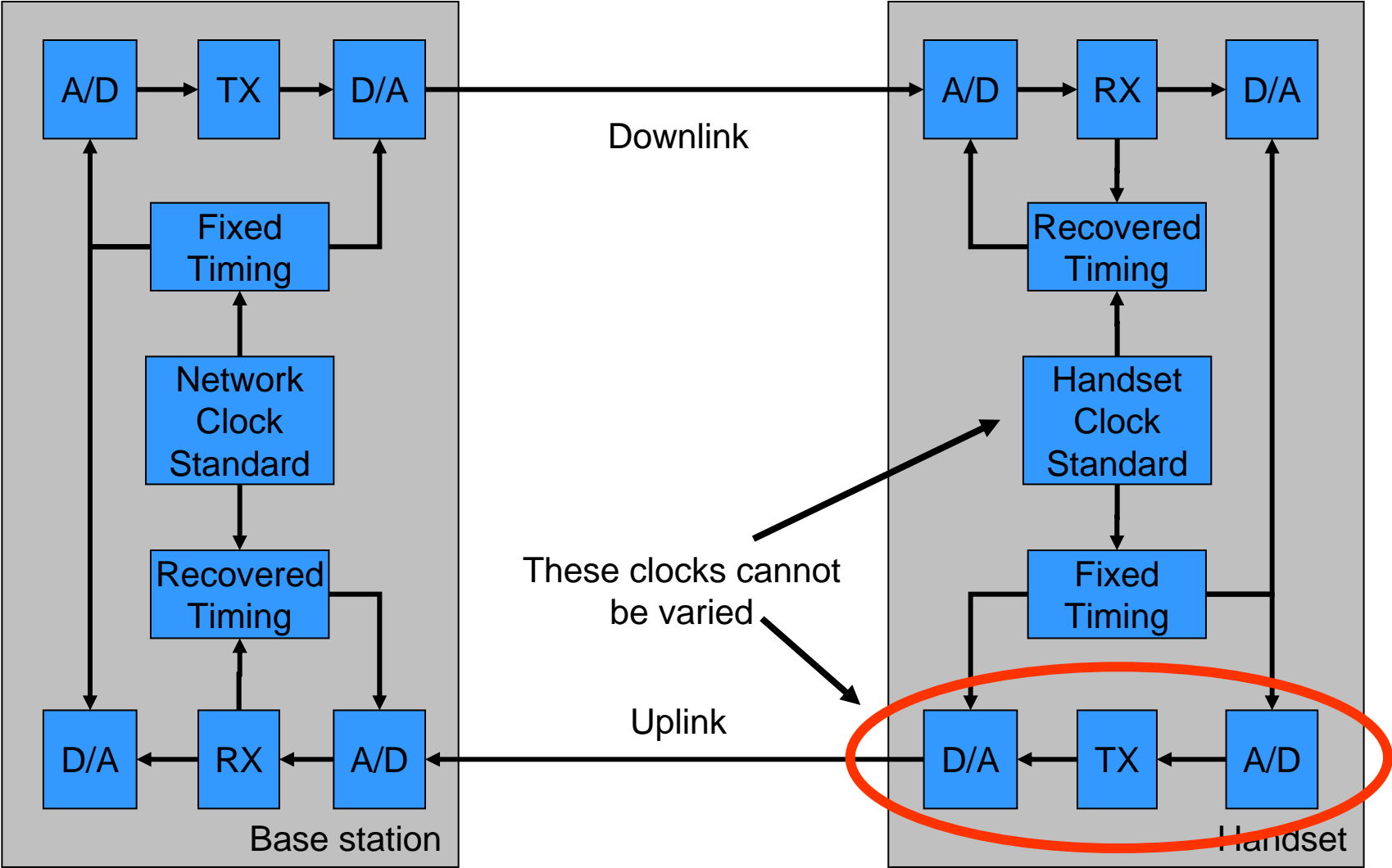

Timing adjustment in digital receiver

Desired channel response

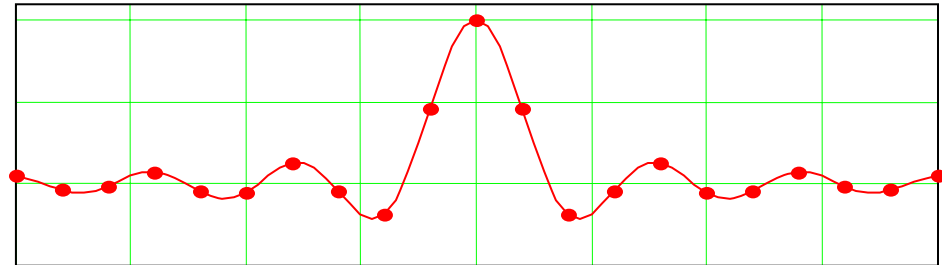

Timing adjustment in digital receiver

Desired channel response

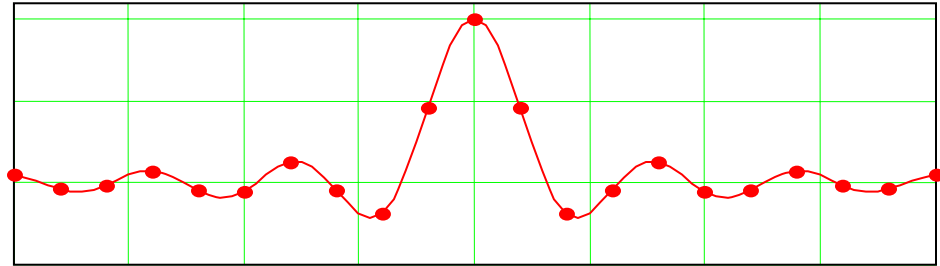

4X oversampled channel response

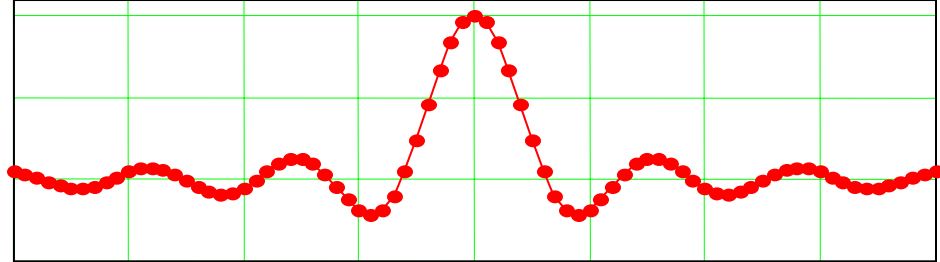

Timing adjustment in digital receiver

Desired channel response

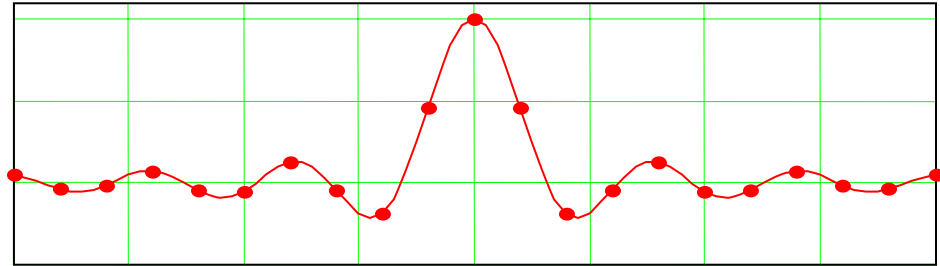

4X oversampled channel response

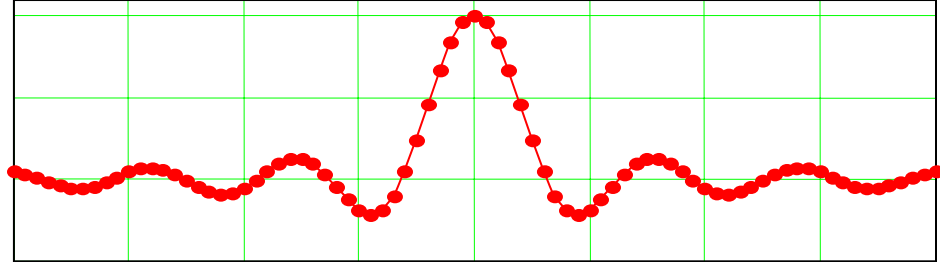

4X oversampled channel response separated into 4 different filters

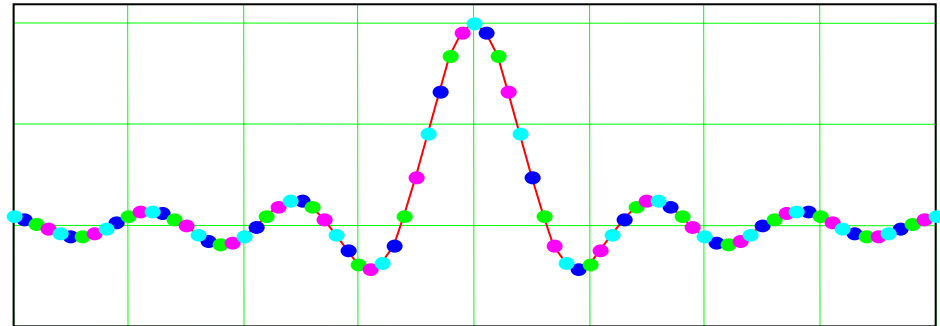

Timing adjustment in digital receiver

Desired channel response

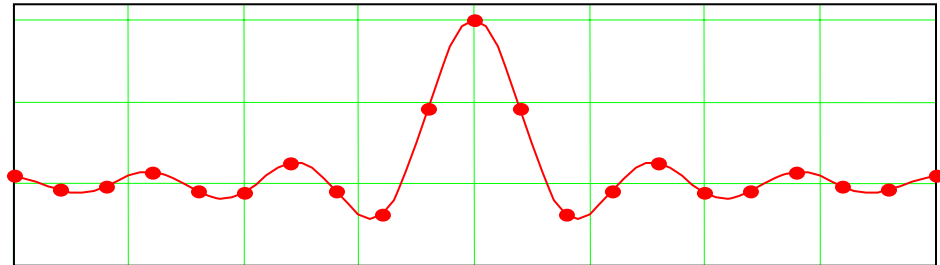

4X oversampled channel response

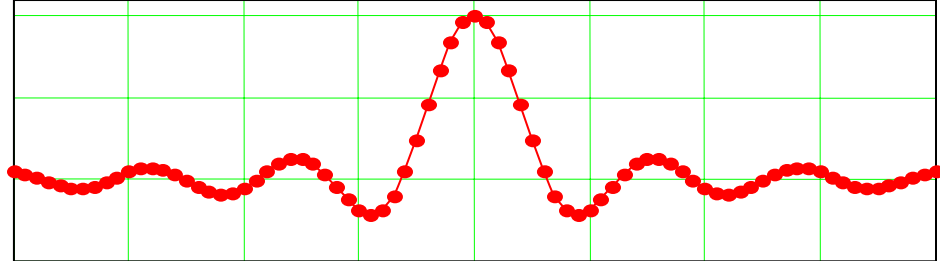

4X oversampled channel response separated into 4 different filters

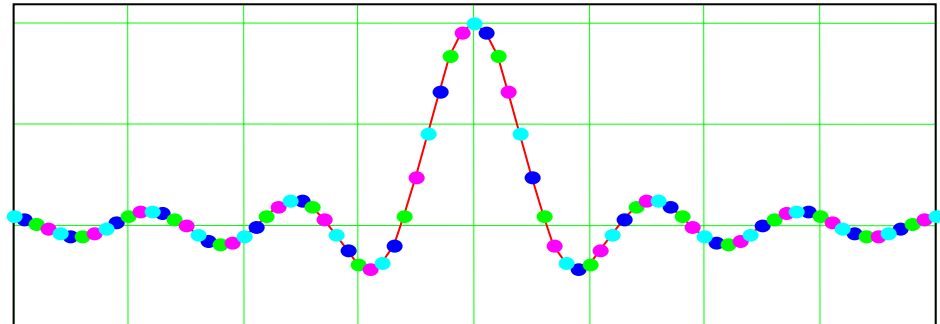

channel response from 1 sample delay filter

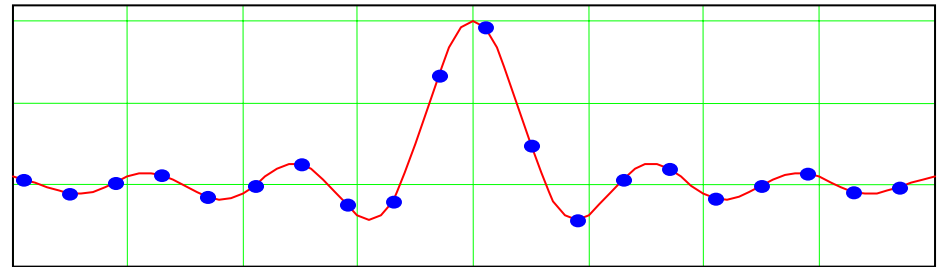

Timing adjustment in digital receiver

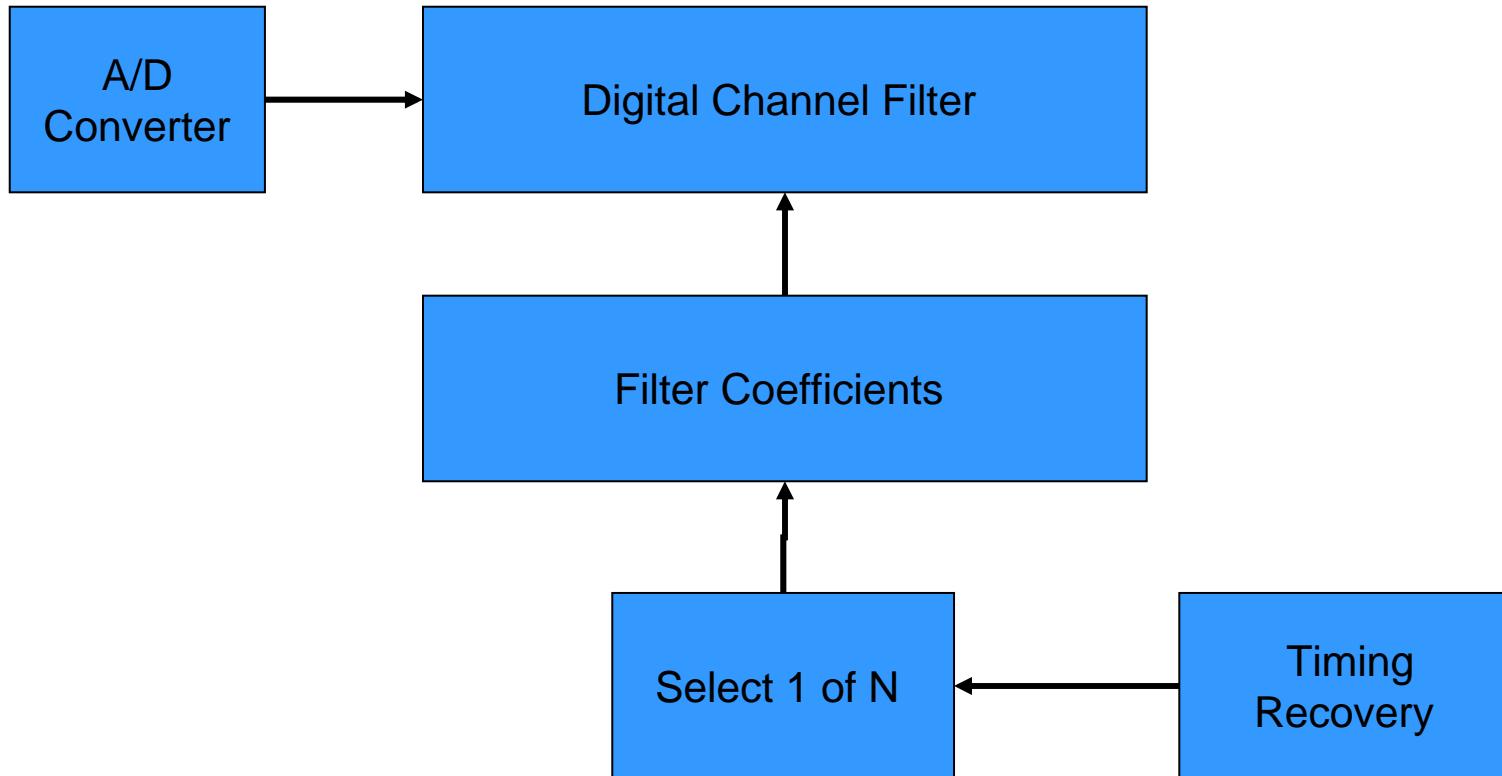

Digital output buffering

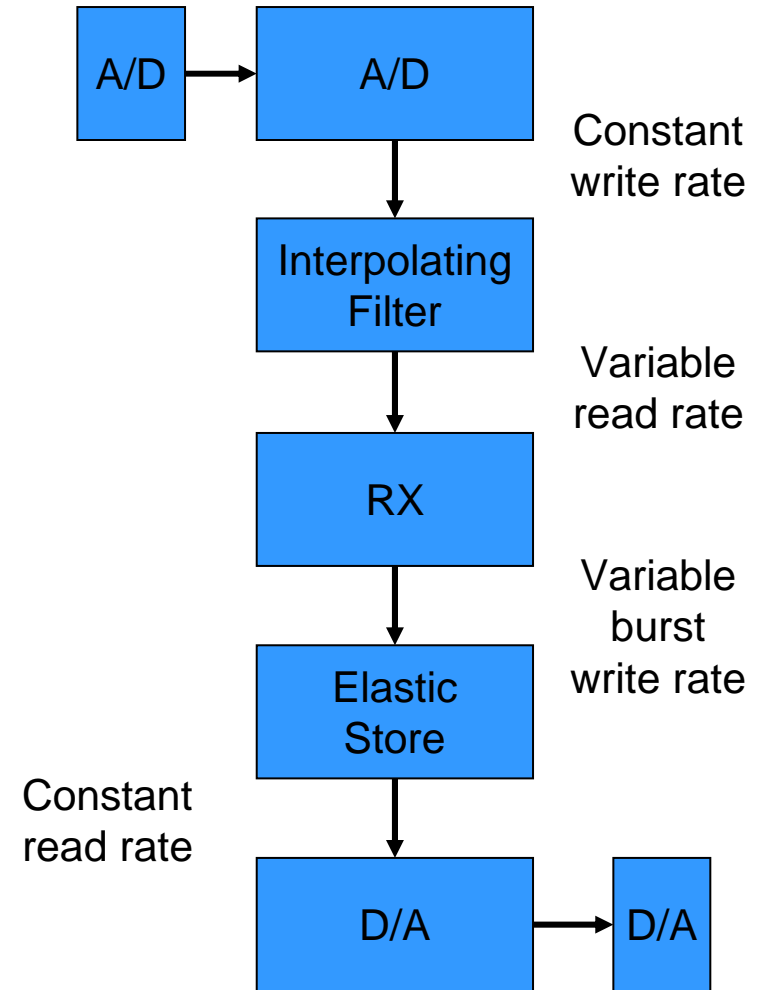
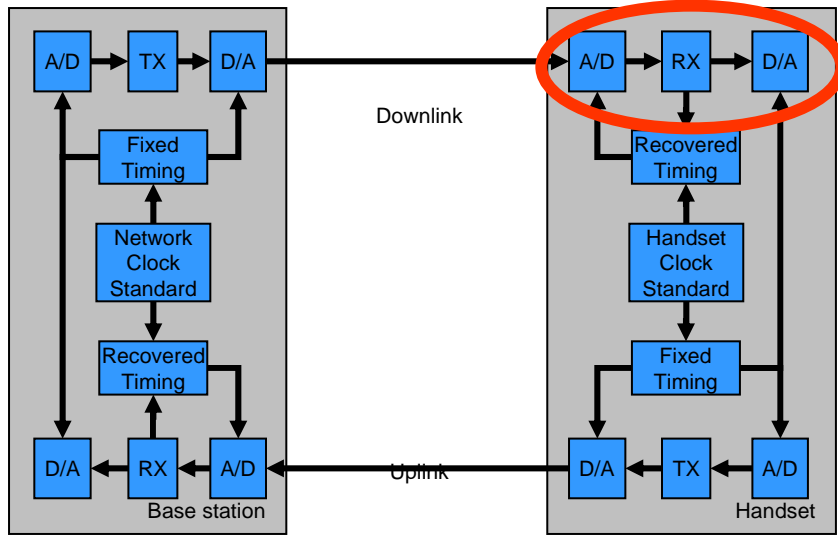

References

- McNair, B., Gupta, S., Kostic, Z., Sollenberger, N., "*Experimental Results for Extensions to the IS-136 TDM Standard Based on Higher Level Modulation, Coherent Detection, and Equal Gain Antenna Combining*," Proc. IEEE Vehicular Technology Conference, VTC99, Houston, TX, May 1999. (available at <http://www.novidesic.com/pubs/vtc99-361a.pdf>)
- Kostic, Z., McNair, B., Sollenberger N., "*Experimental Performance Results of an Indoor Wireless Extension of IS-136 Based on $\pi/8$ D8PSK, Coded Modulation, and Antenna Diversity*," Proc. IEEE Vehicular Technology Conference, VTC98 Ottawa, Canada, May 1998. (available at <http://www.novidesic.com/pubs/vtc98%20-%20paper%2034-2.pdf>)

Homework #8

- Project due next week
- Final will be posted next week, due 1 week later