

Signal Generators

Oscillators

Astables, bistables

Waveshaping

PLLs

NCOs

AWGs

Colpitts and Hartley Oscillators

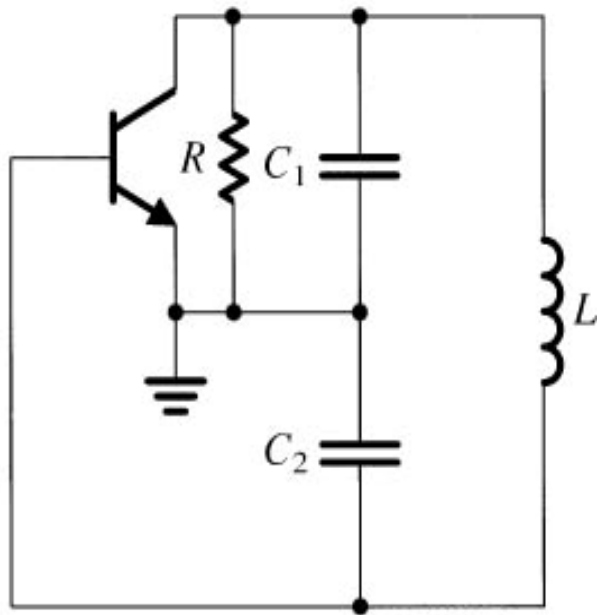

(a)

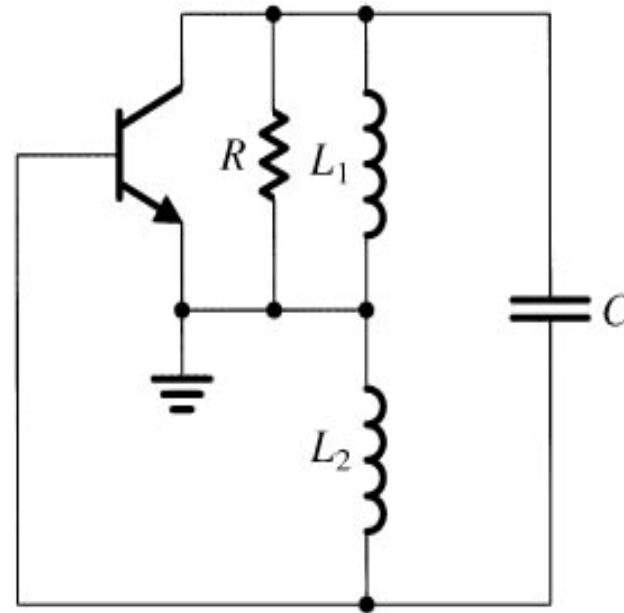

(b)

Collpits Oscillator

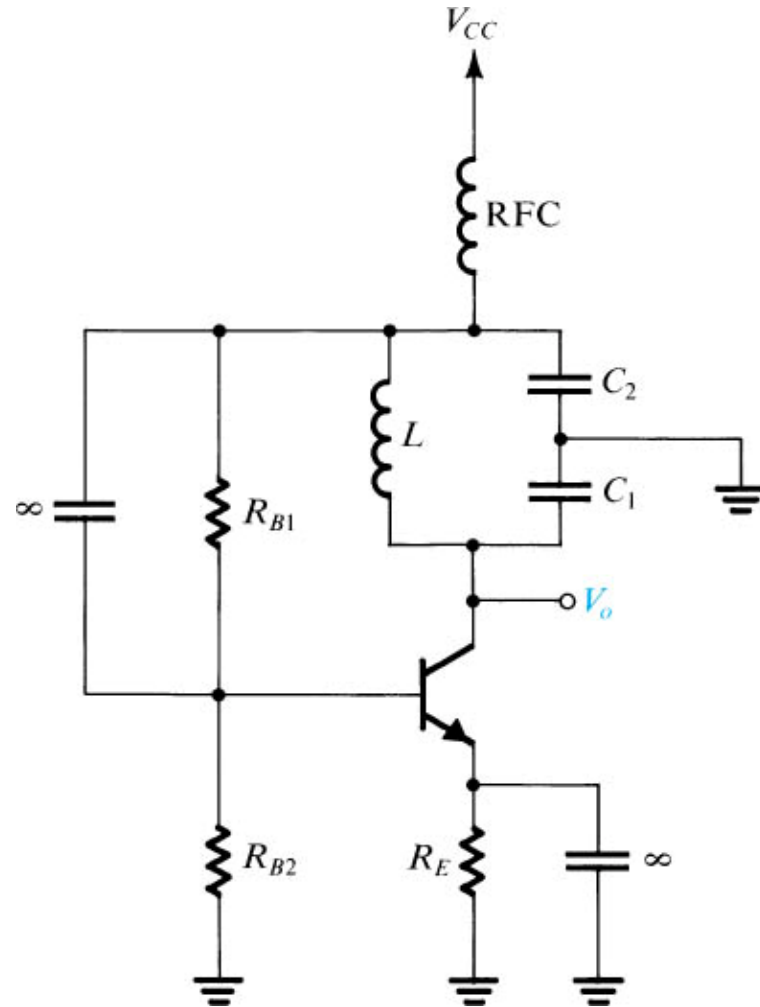

Piezoelectric Crystal



(a)

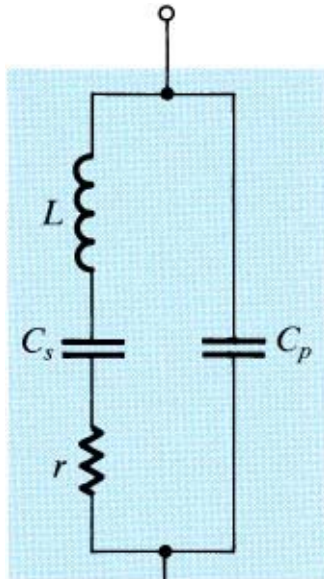

(b)

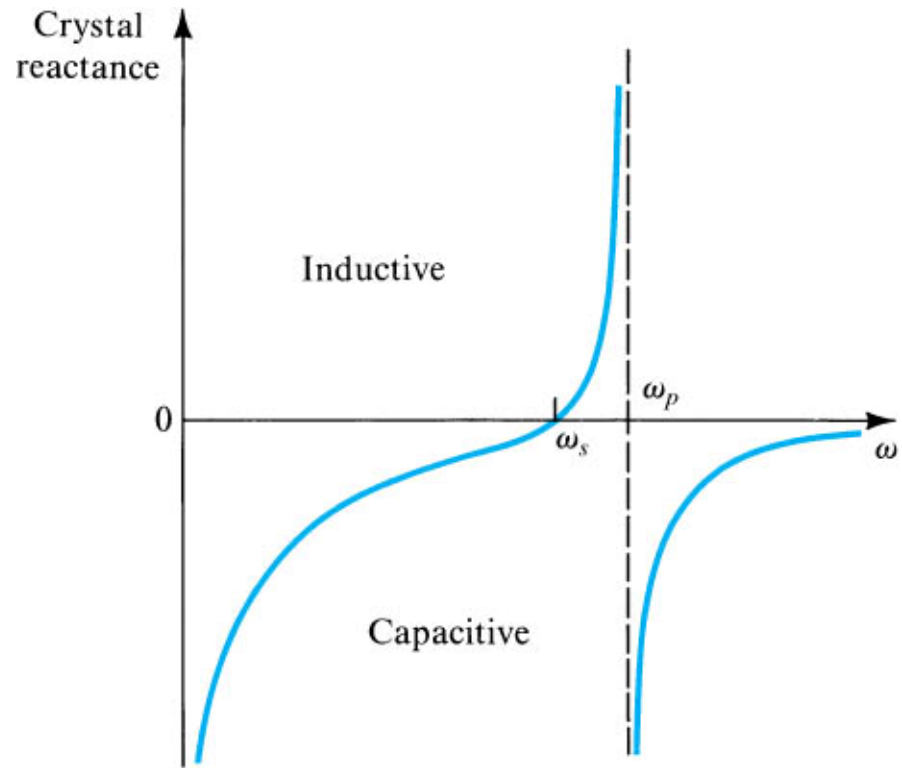

(c)

Pierce Oscillator

CMOS inverter as an amplifier.

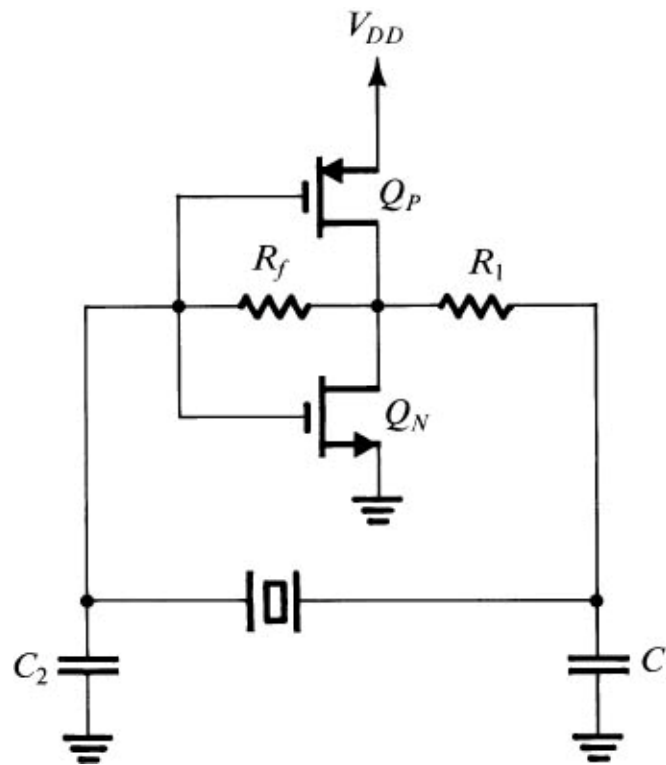

Pierce Oscillator

Alternate BJT Pierce oscillator

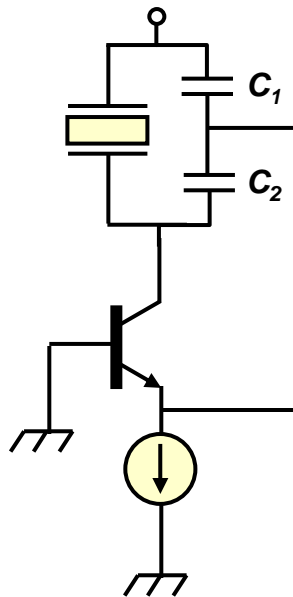

Bistable Operation

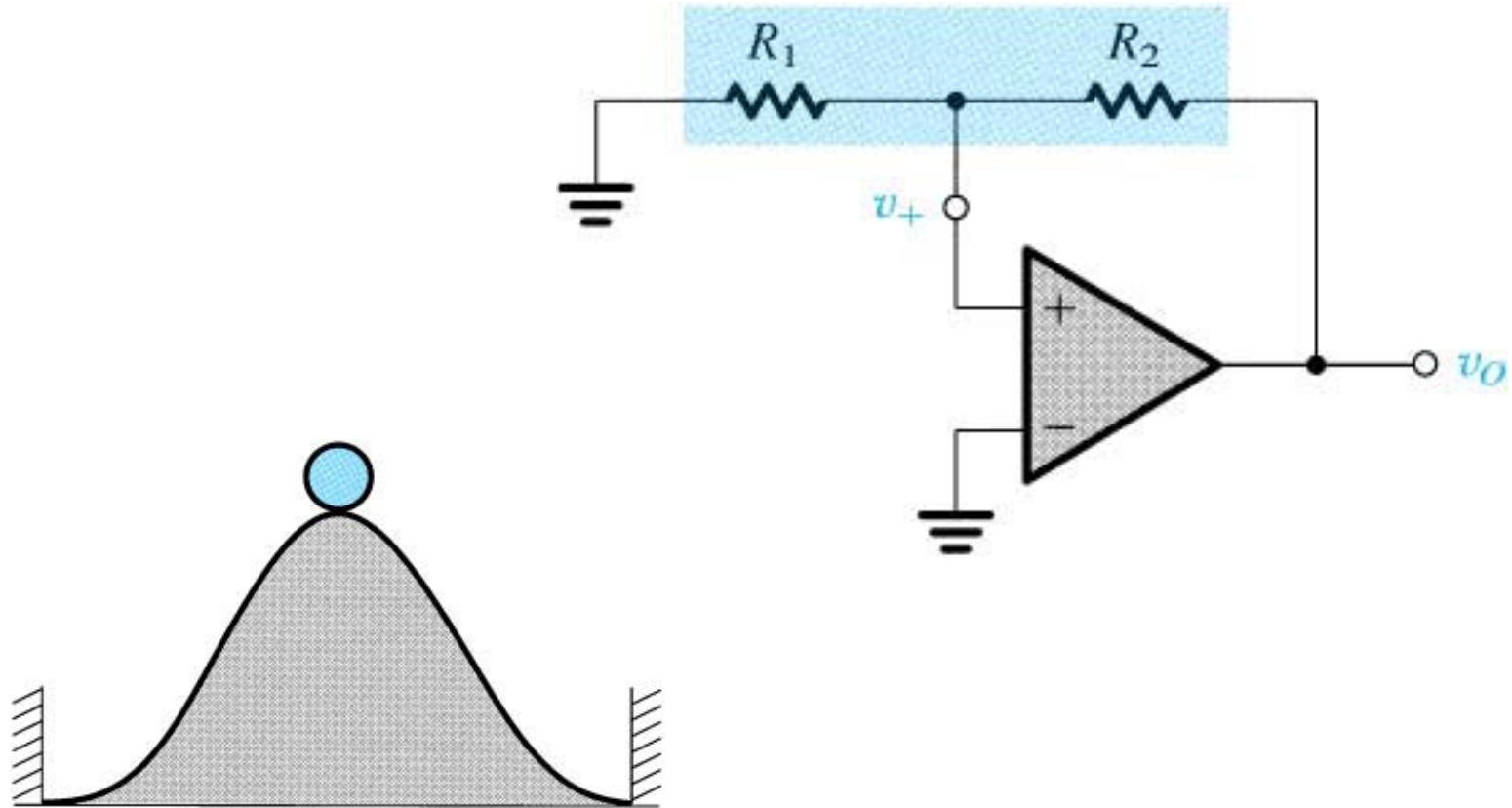

Bistable

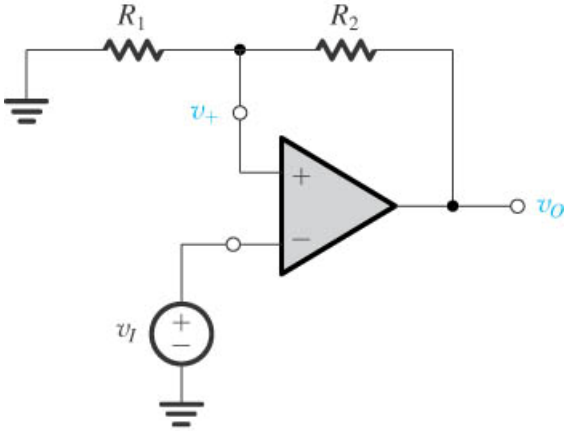

(a)

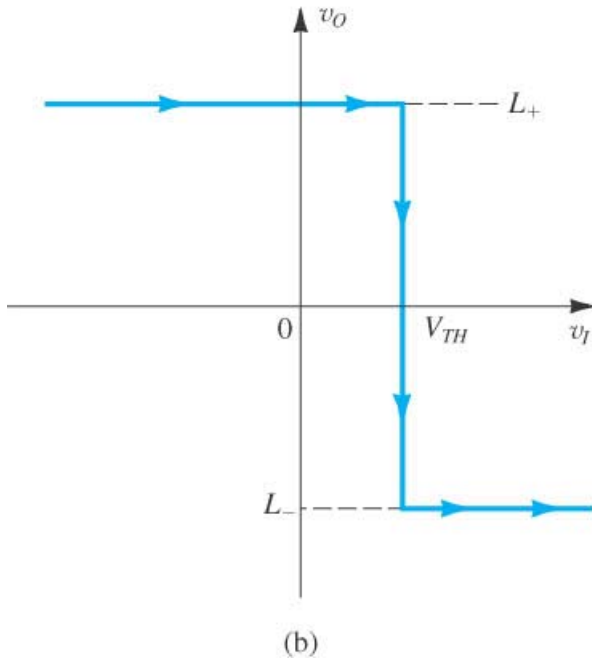

(b)

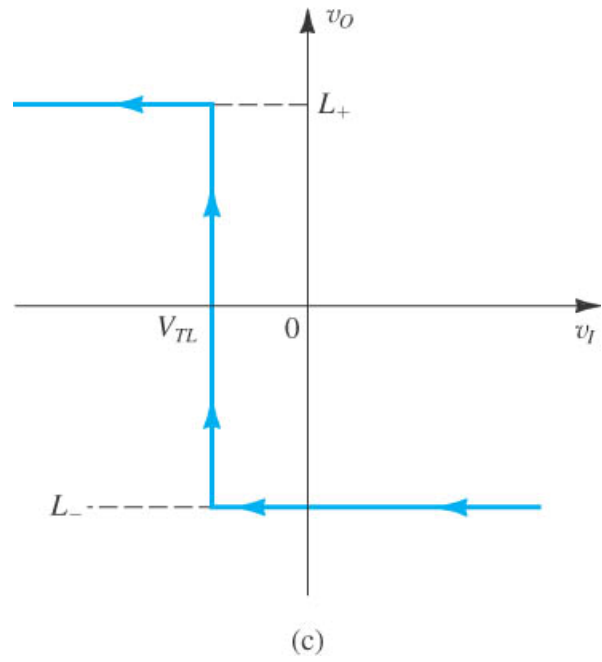

(c)

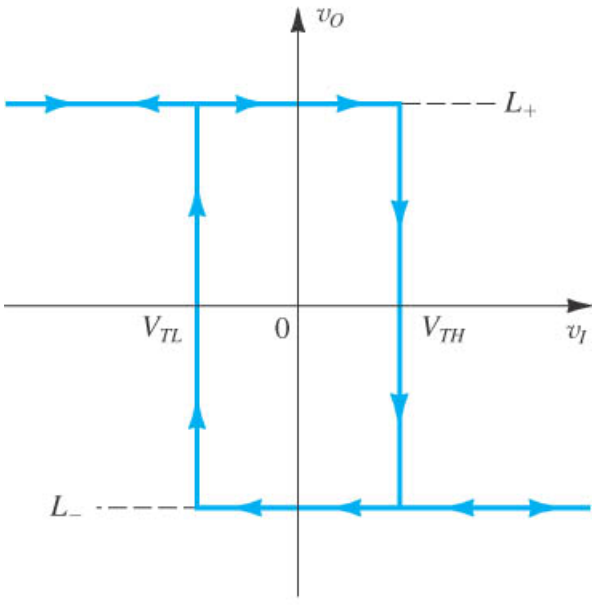

(d)

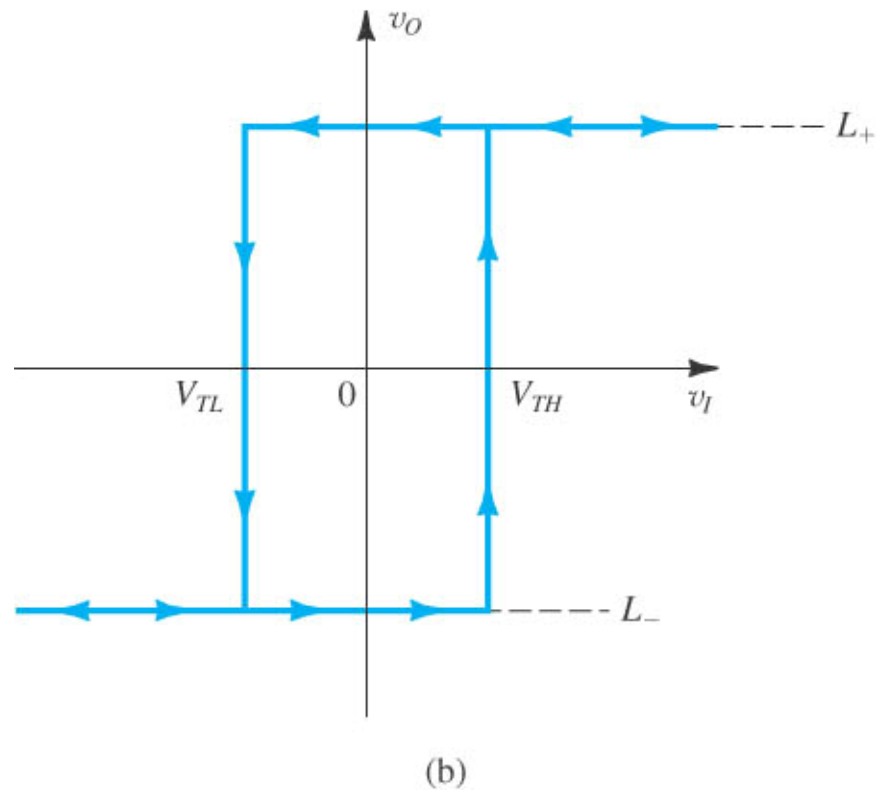
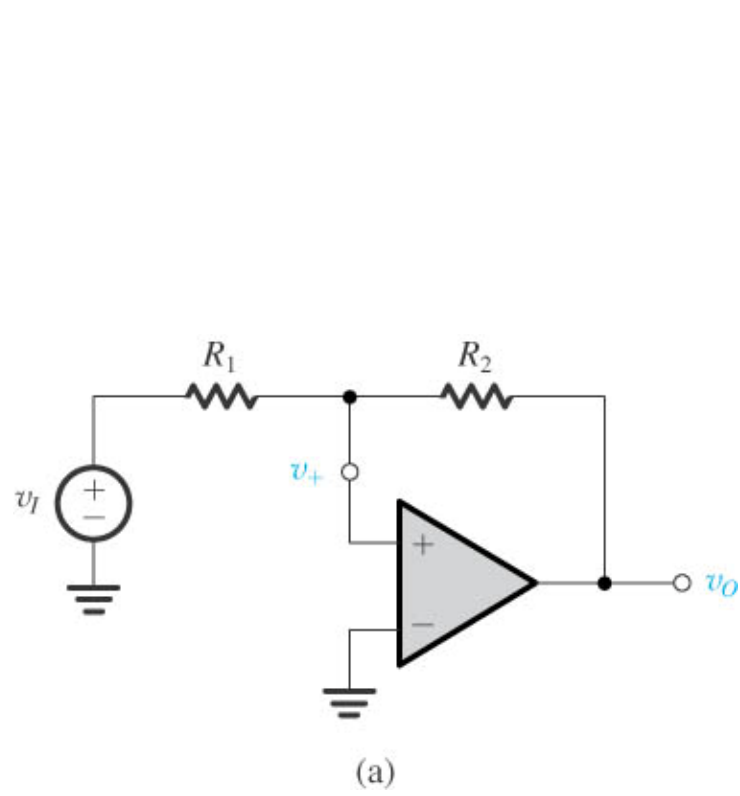

Hysteresis

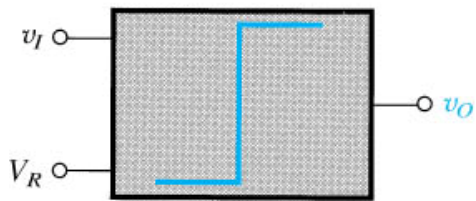

(a)

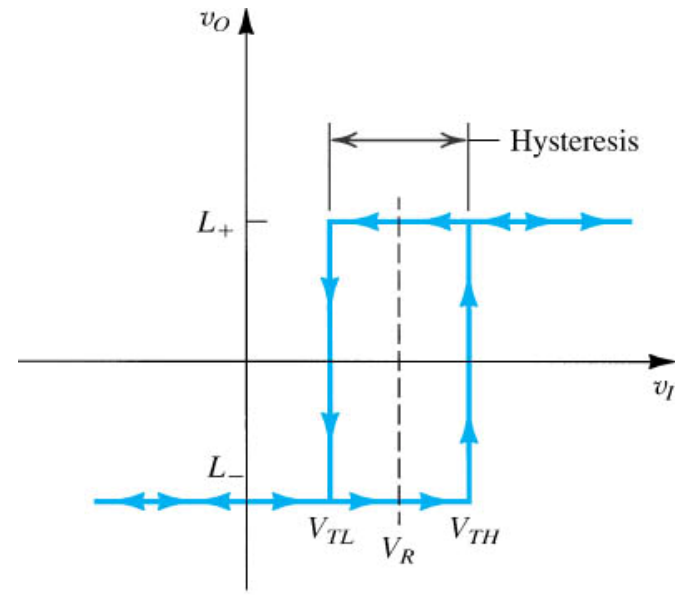
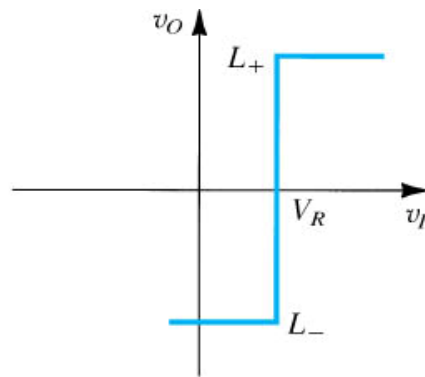

(b)

Noisy Signal

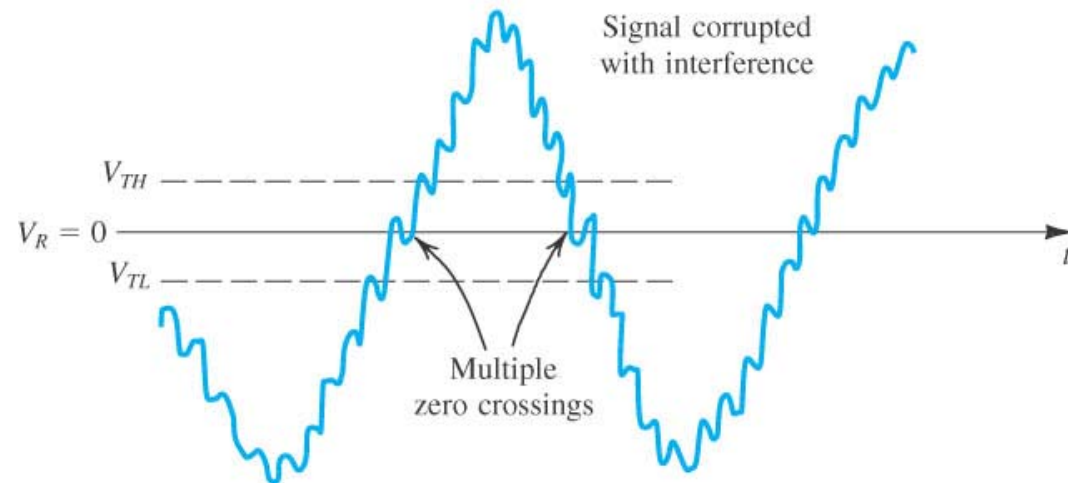
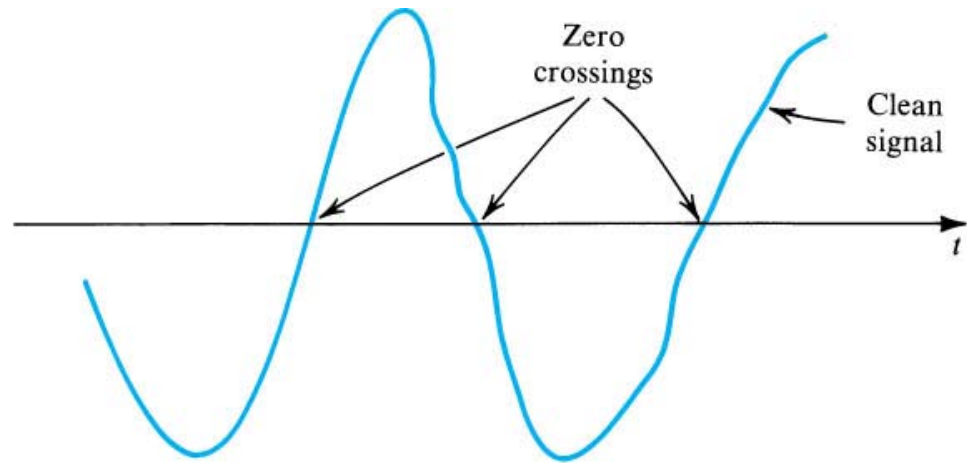

Limiter

a) $L_+ = V_{Z_1} + V_D$ and $L_- = -(V_{Z_2} + V_D)$,

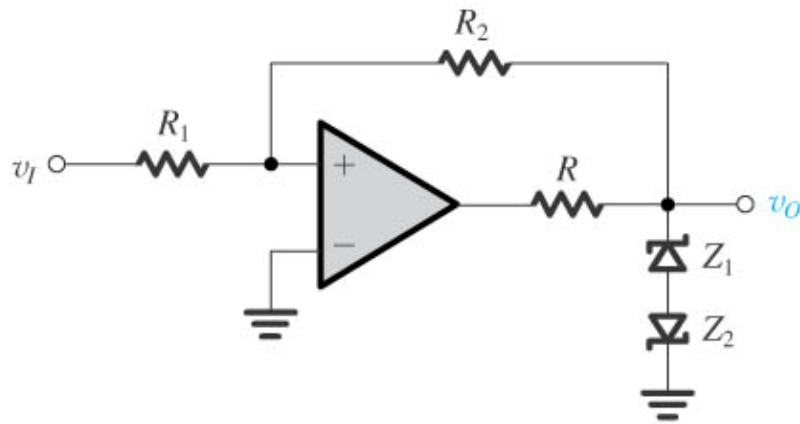

(b) $L_+ = V_Z + V_{D_1} + V_{D_2}$ and $L_- = -(V_Z + V_{D_3} + V_{D_4})$.

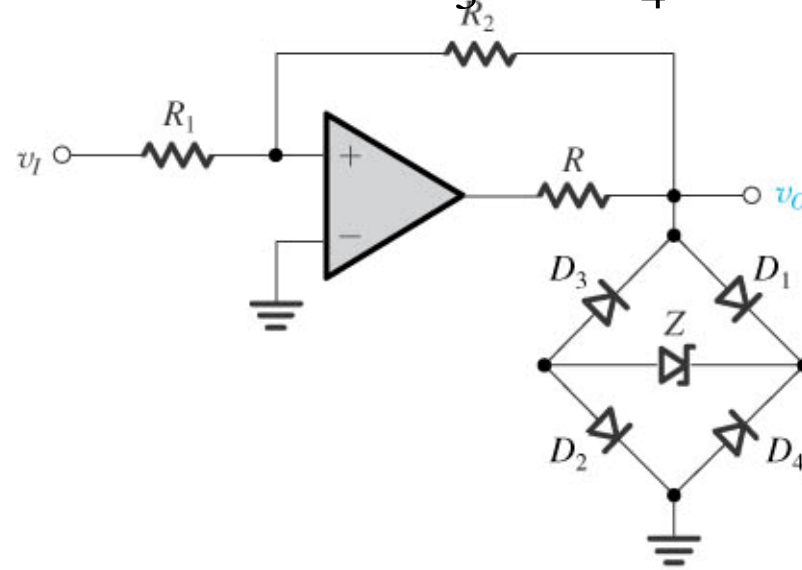

Limiter^(a) circuits = more precise output^(b) levels for bistable circuit.

R according to current required for the proper operation of the zener diodes.

Astable w/ feedback

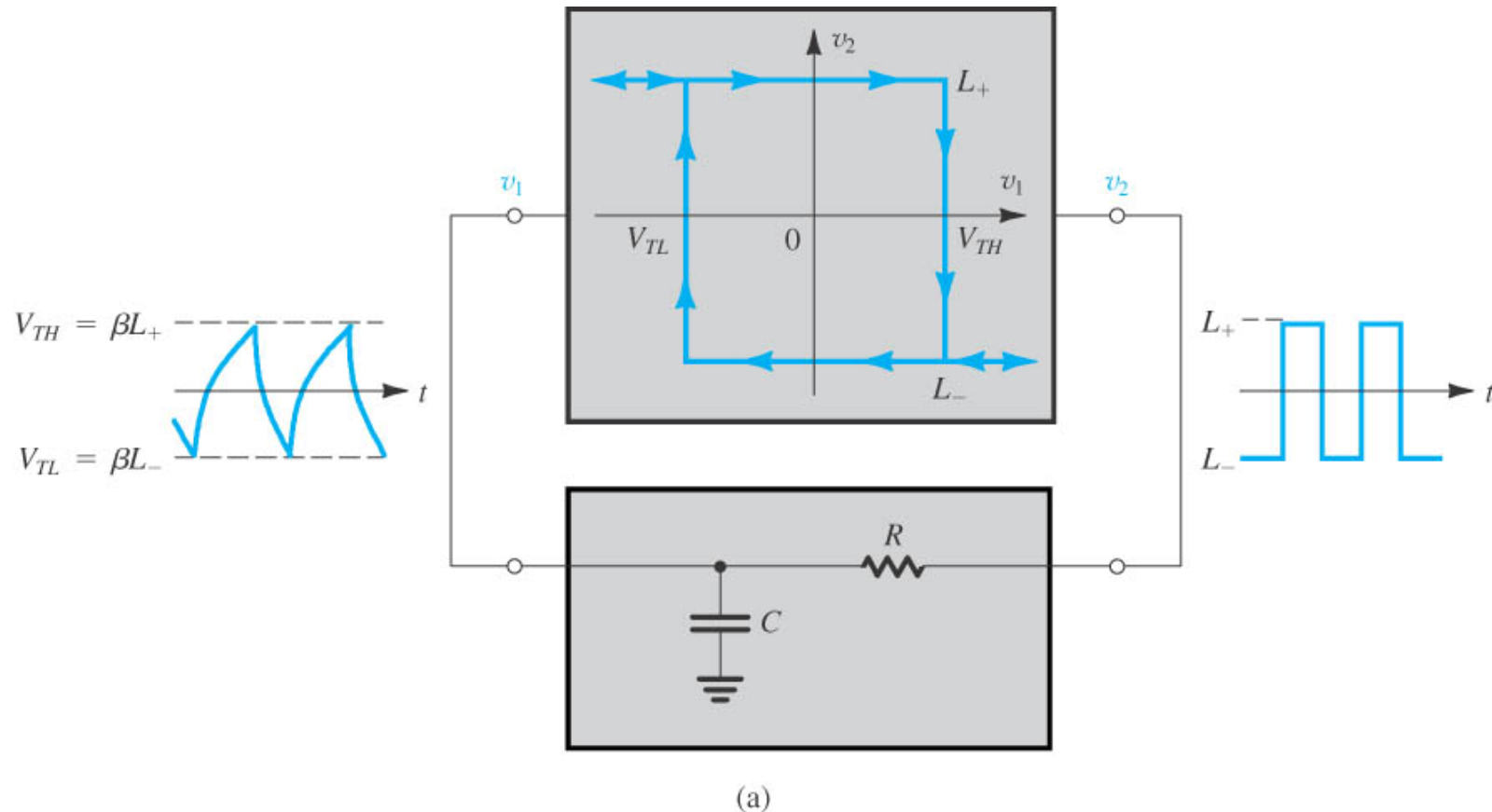

A bistable multivibrator with inverting transfer characteristics in a feedback loop with an RC circuit results in a square-wave generator.

Astable

The circuit obtained when the bistable multivibrator is implemented with the circuit

(This circuit is called an astable multivibrator.)

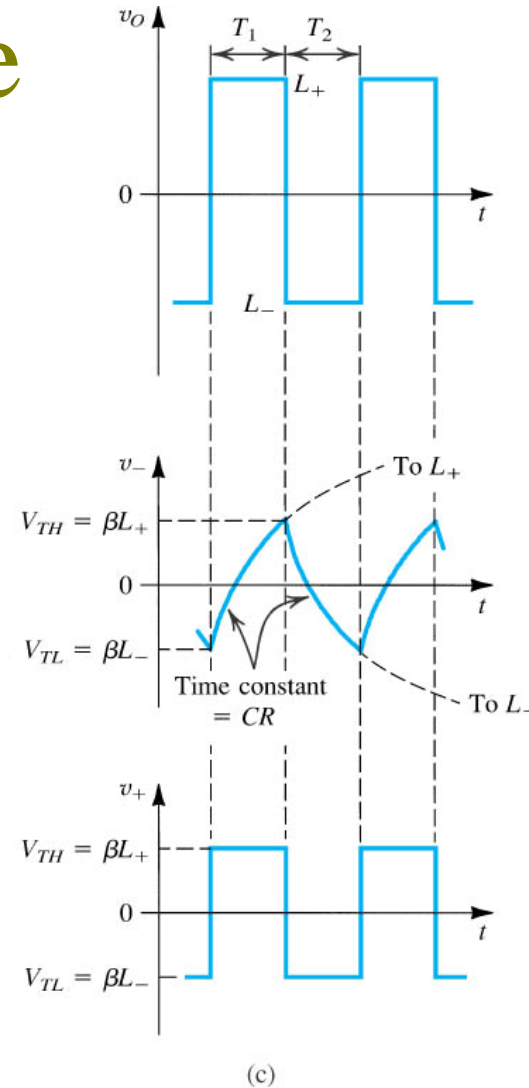
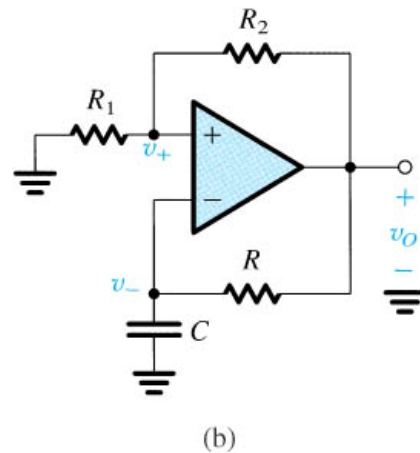

c) Waveforms at various nodes of the circuit in (b).

Ckt for triang/square wave

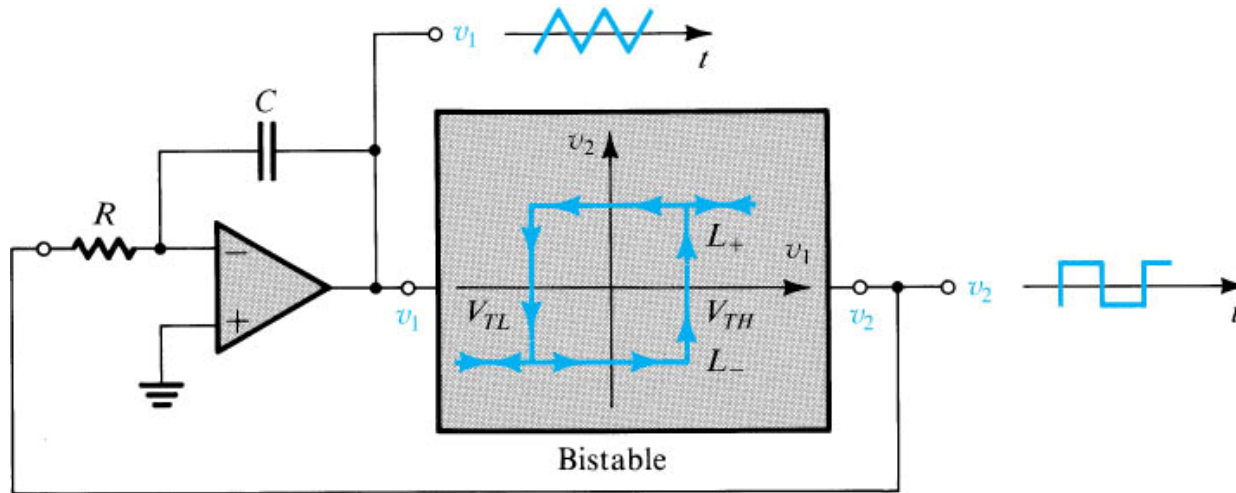

(a)

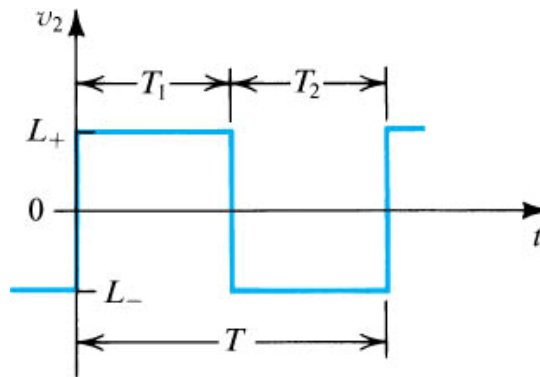

(b)

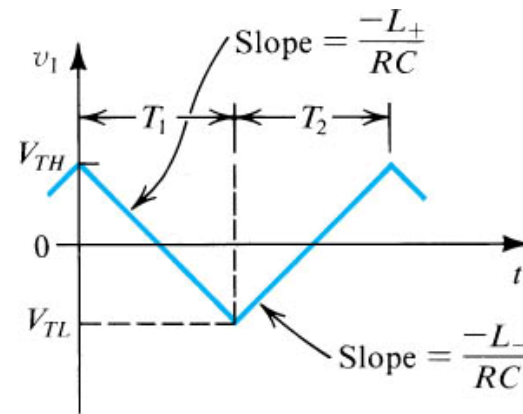

(c)

A general scheme for generating triangular and square waveforms.

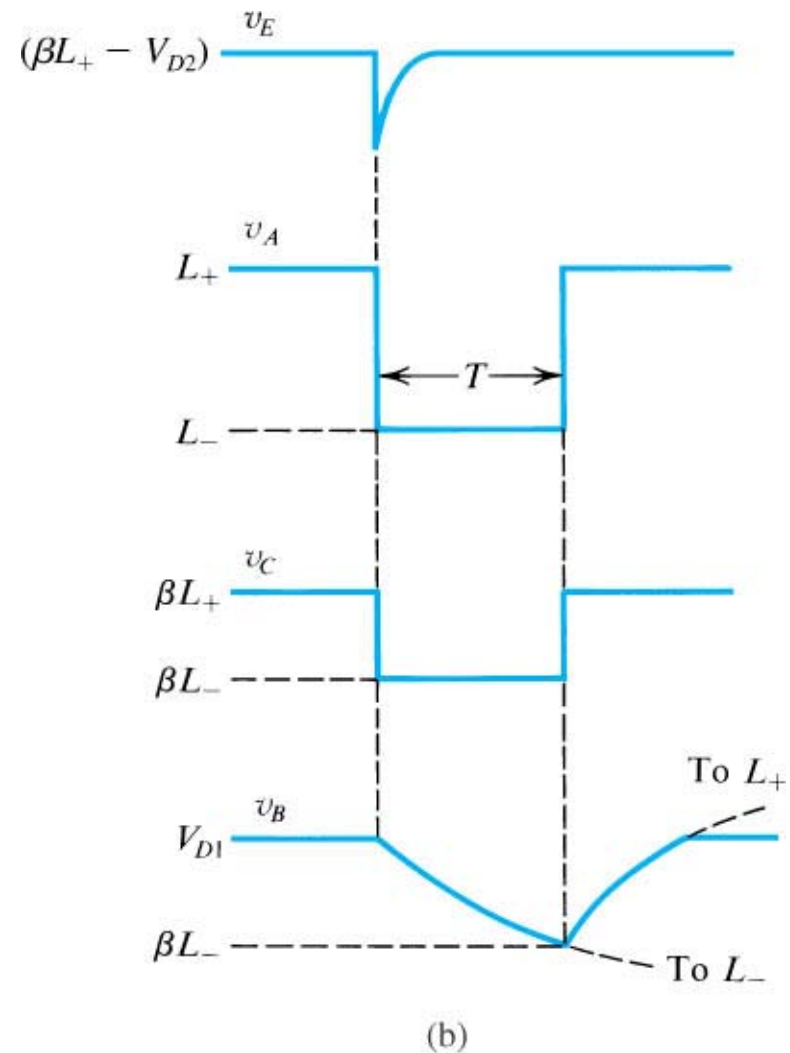
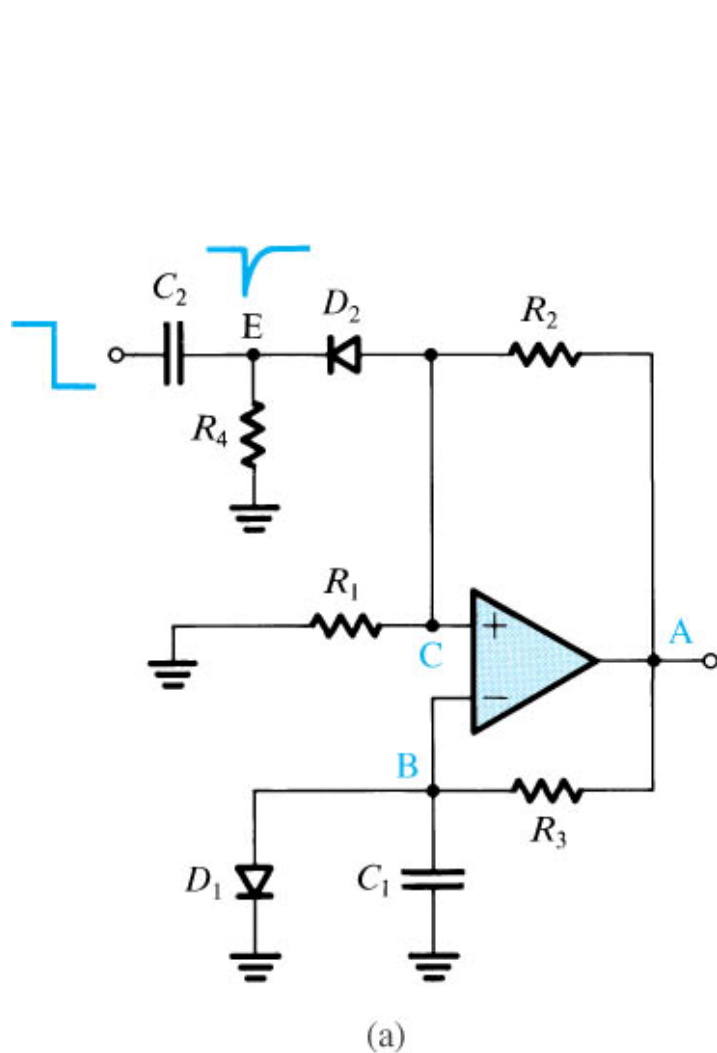

(a) An op-amp monostable circuit. **(b)** Signal waveforms in the circuit of (a).

555 IC

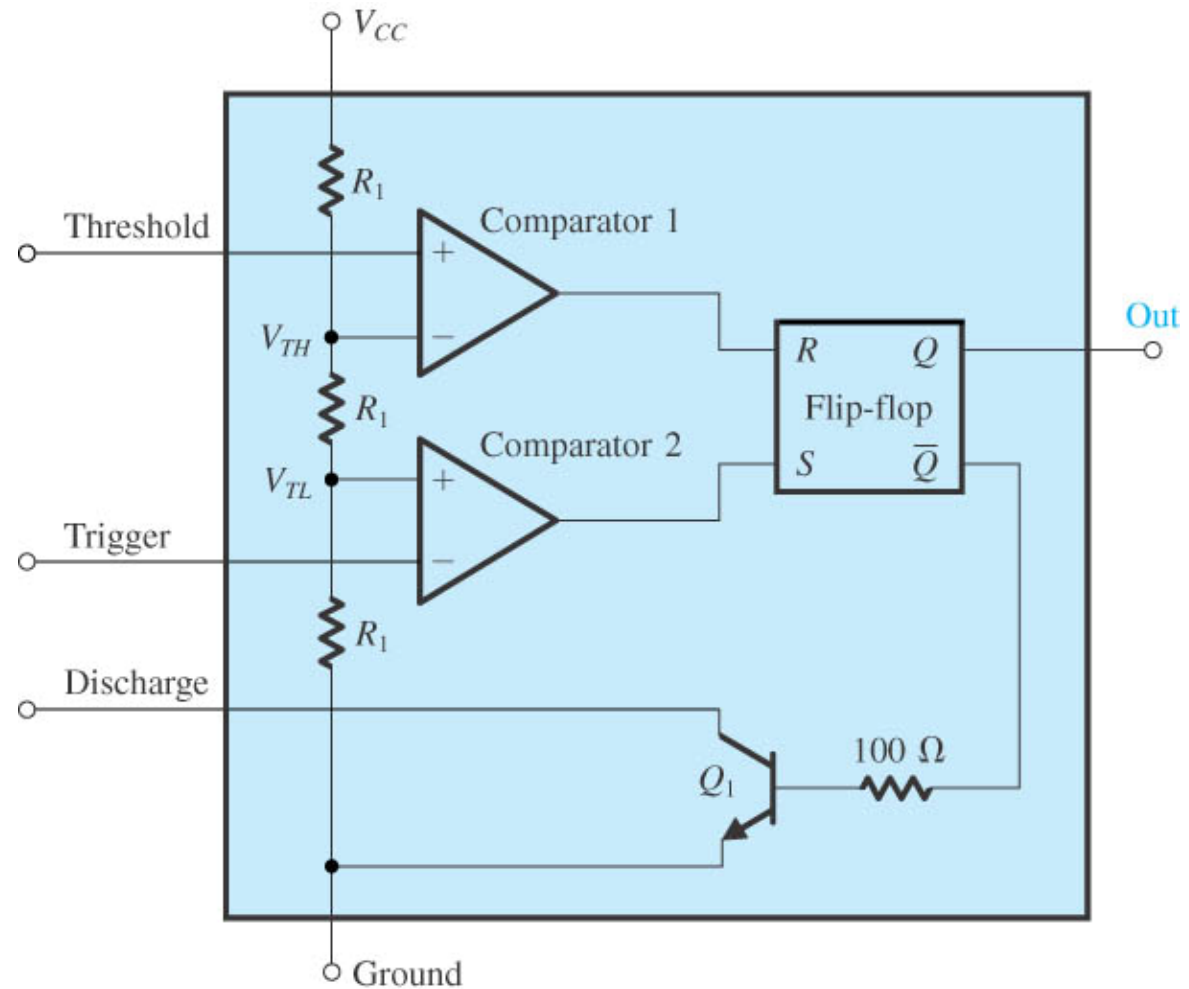

internal circuit of the 555 integrated-circuit timer.

555 for monostable

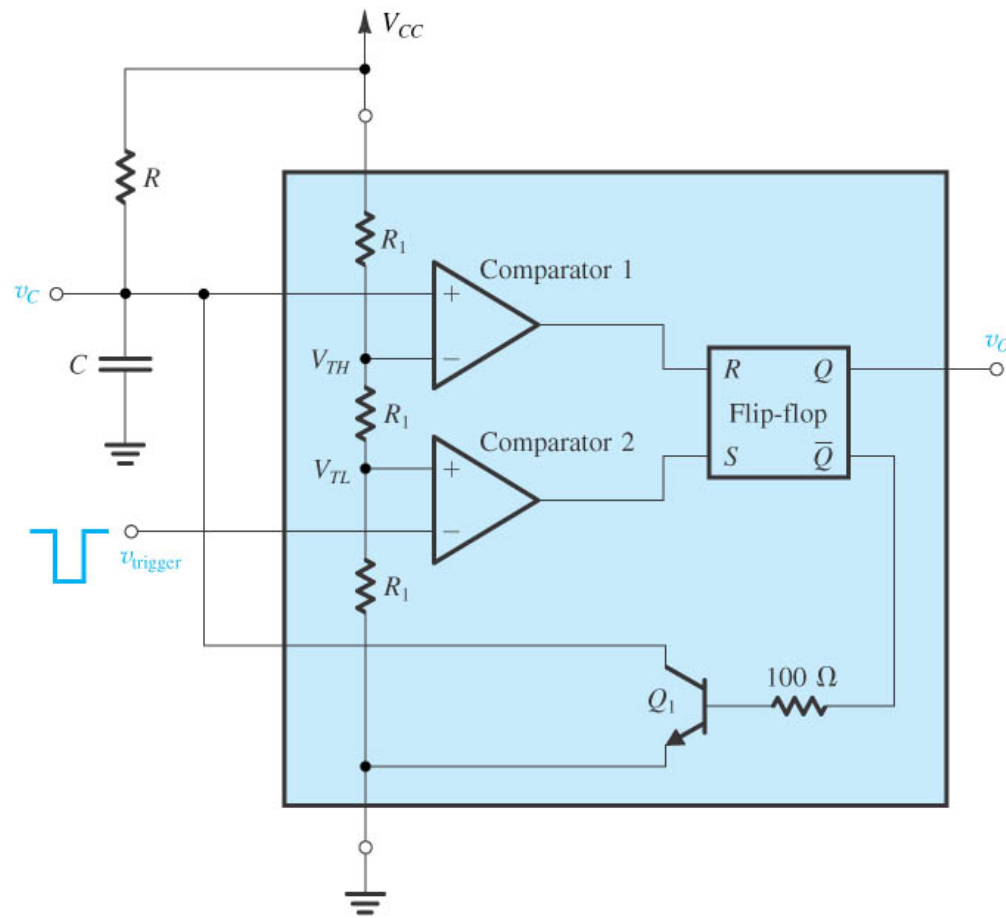

(a)

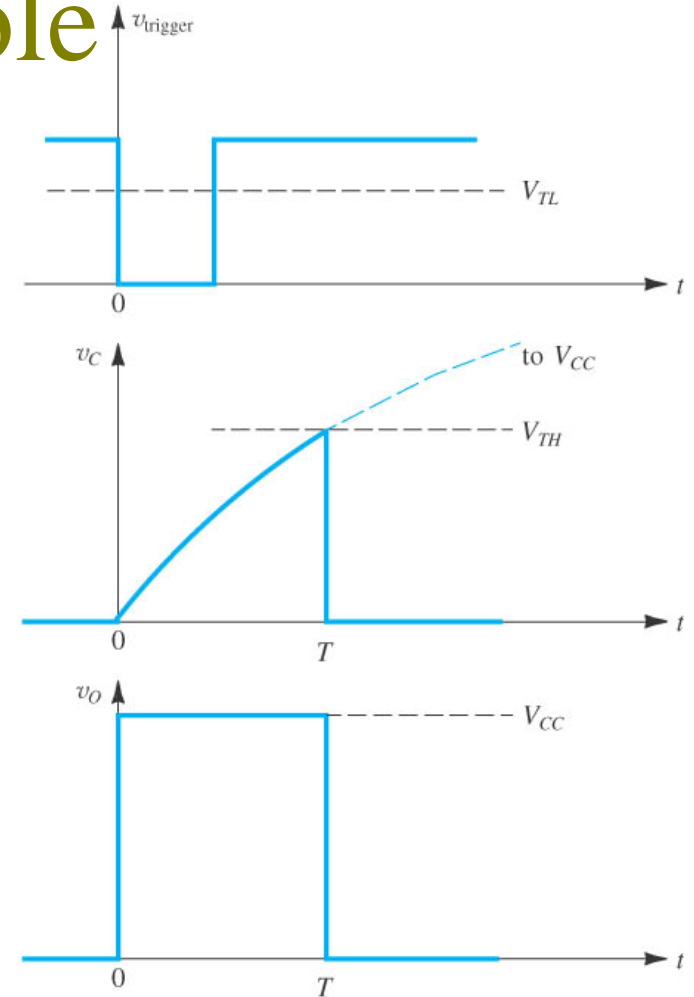

(b)

a) The 555 timer connected to implement a monostable multivibrator. **(b)** Waveforms of the circuit in (a).

555 for astable

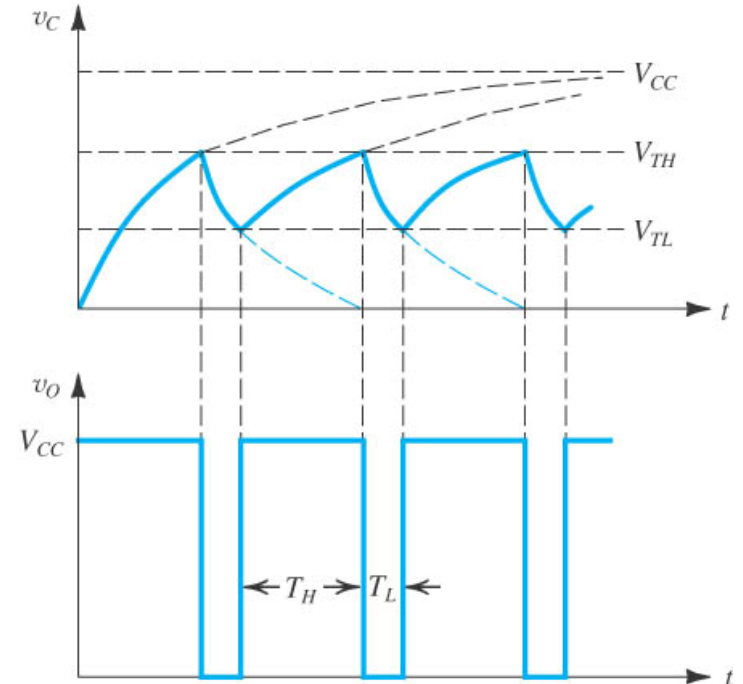
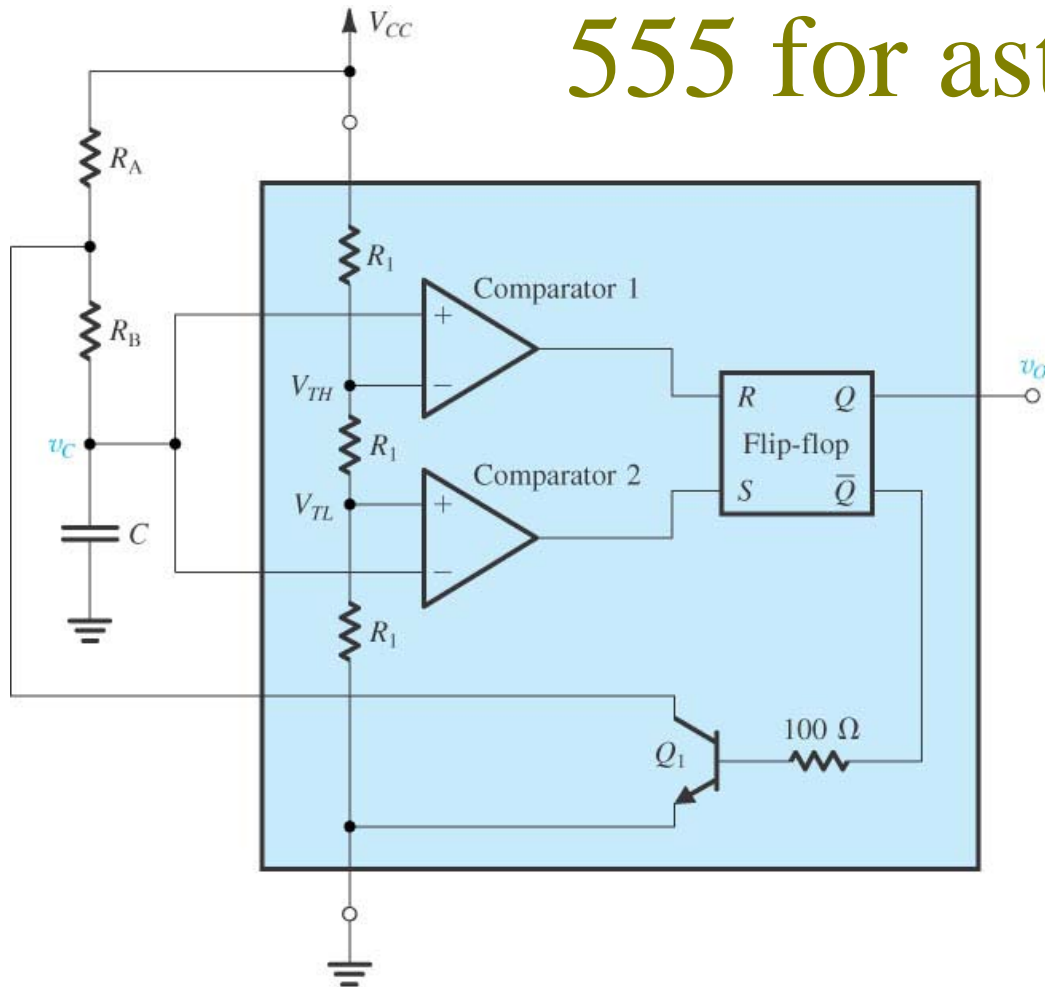

(a)

(b)

(a) The 555 timer connected to implement an astable multivibrator.
(b) Waveforms of the circuit in (a).

Triangle \rightarrow Sinusoid

Using a nonlinear (sinusoidal) transfer characteristic to shape a triangular waveform into a sinusoid.

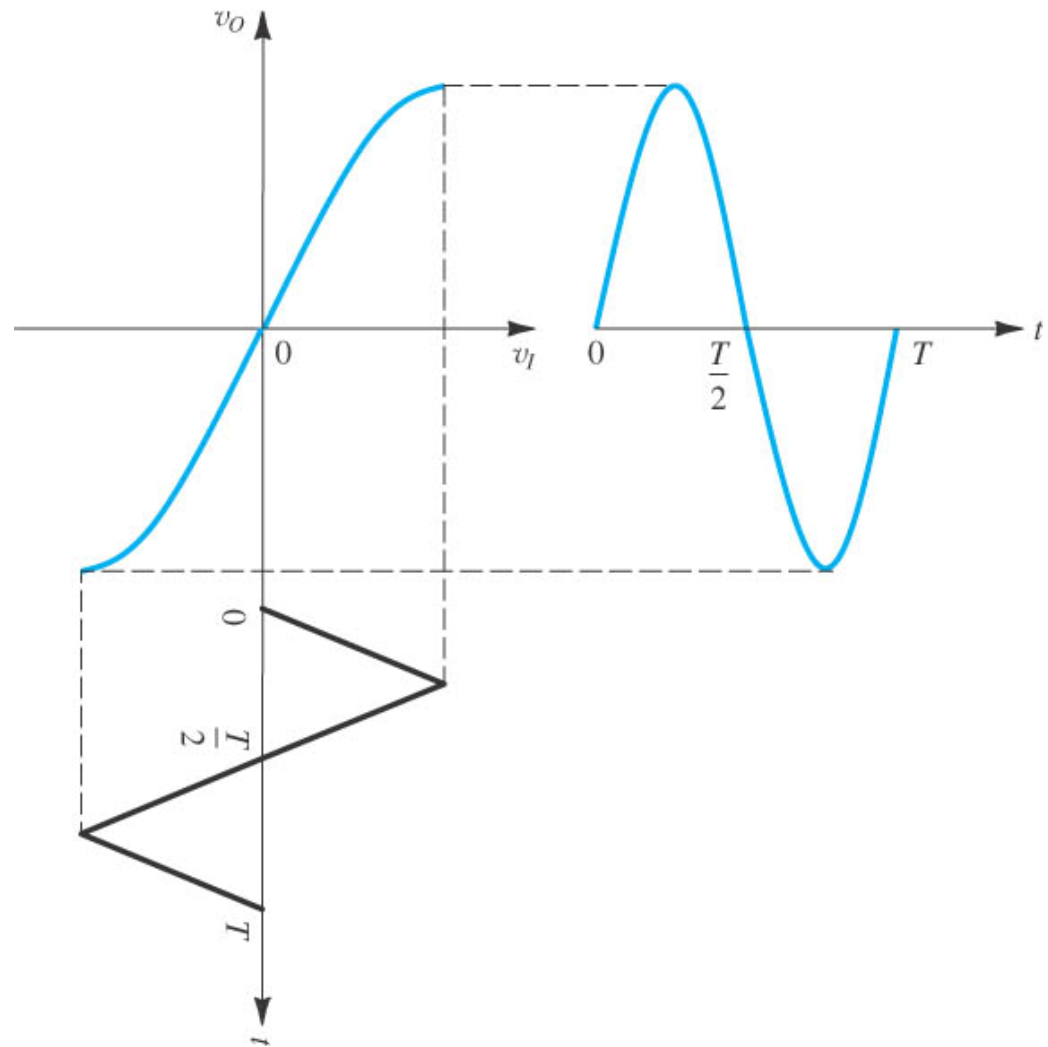

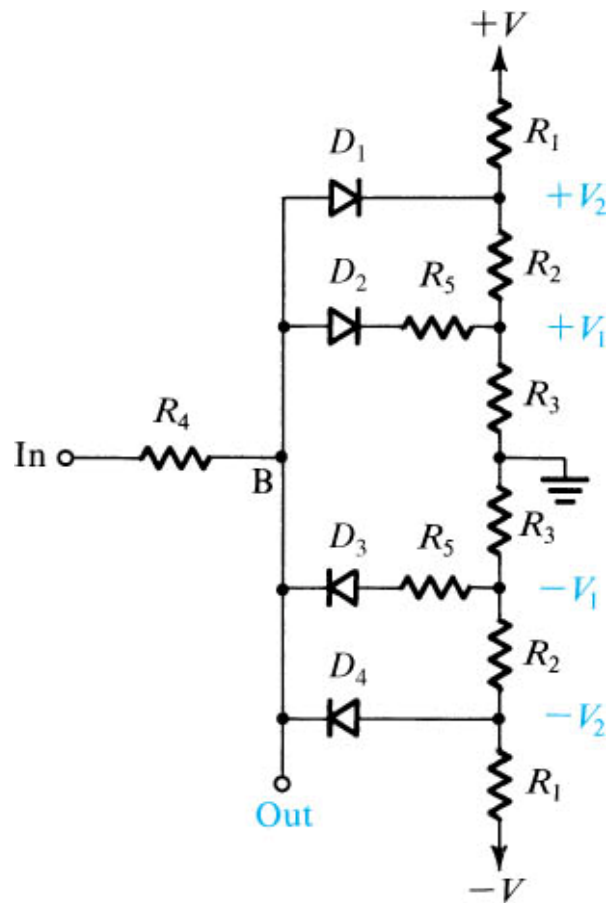

(a)

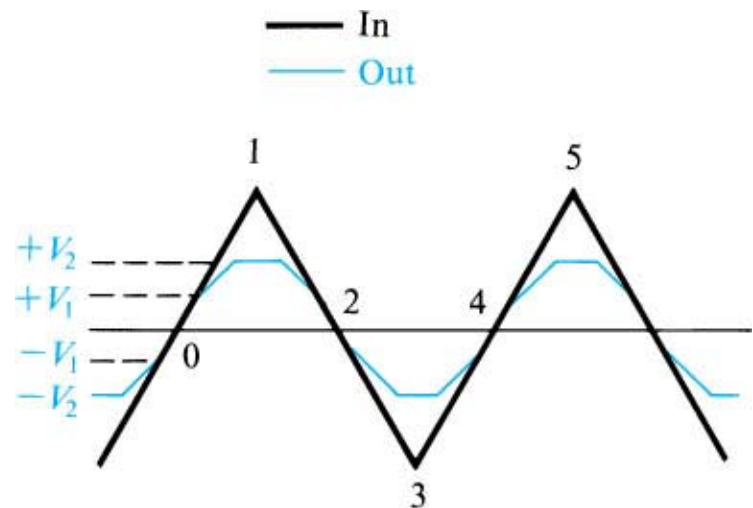

(b)

(a) A three-segment sine-wave shaper. **(b)** The input triangular waveform and the output approximately sinusoidal waveform.

A differential pair with an emitter degeneration resistance used to implement a triangular-wave to sine-wave converter.

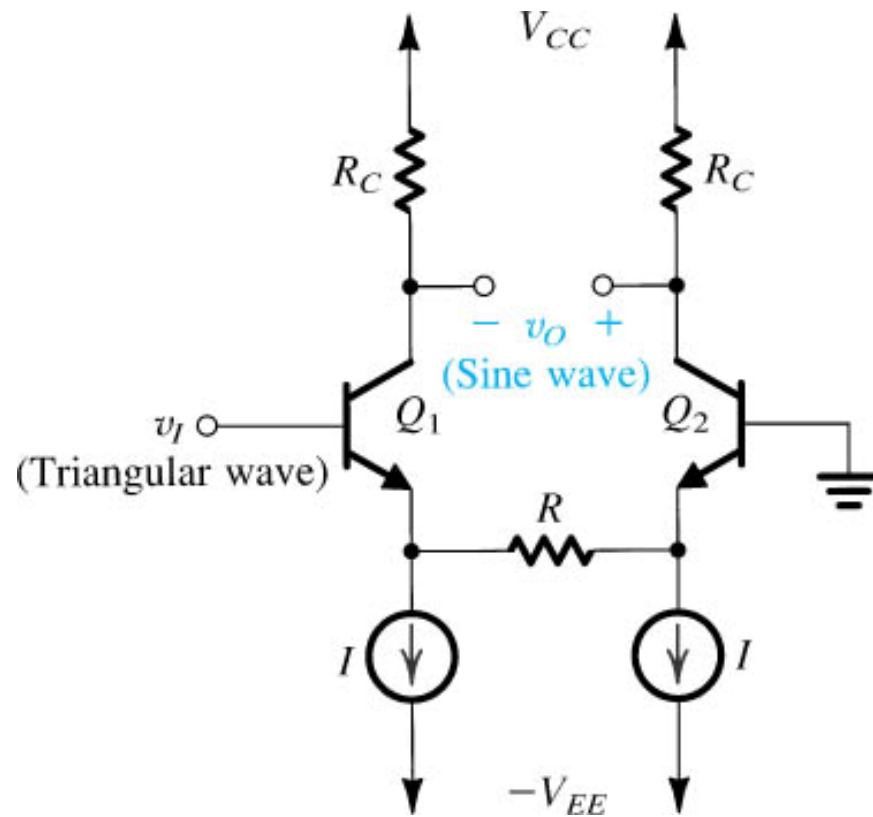
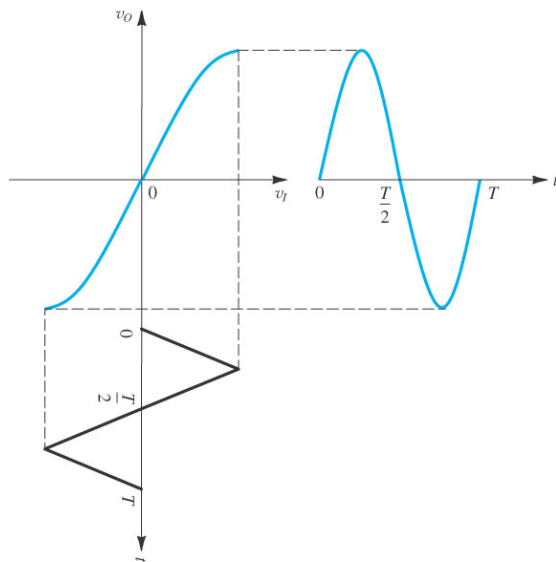

Superdiode

when $v_I > 0$ and the diode conducts, the op amp supplies the load current, and the source is conveniently buffered, an added advantage.

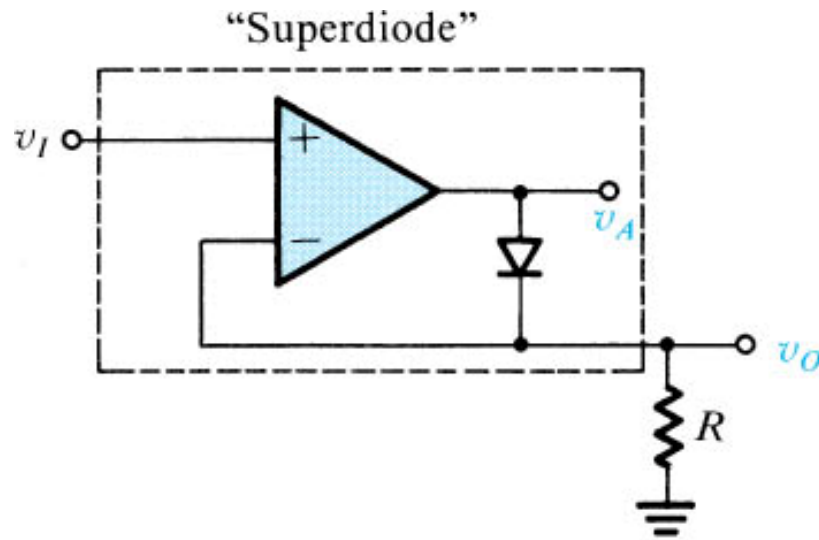

(a)

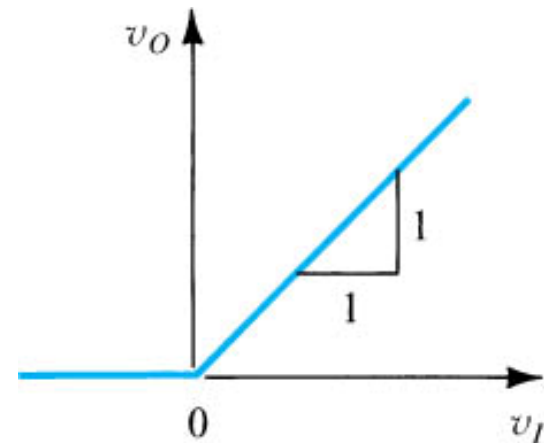

(b)

- (a) The "superdiode" precision half-wave rectifier and
(b) its almost ideal transfer characteristic.

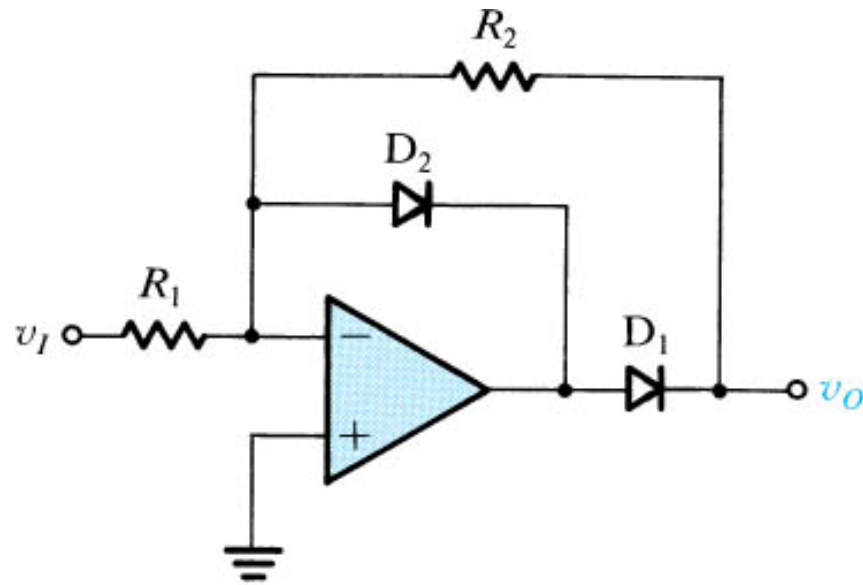

(a)

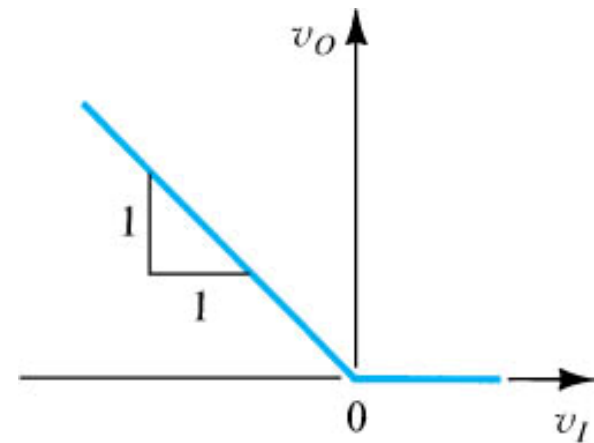

(b)

(a) An improved version of the precision half-wave rectifier: Diode D_2 is included to keep the feedback loop closed around the op amp during the off times of the rectifier diode D_1 , thus preventing the op amp from saturating.

(b) The transfer characteristic for $R_2 = R_1$.

Phase Locked Loops

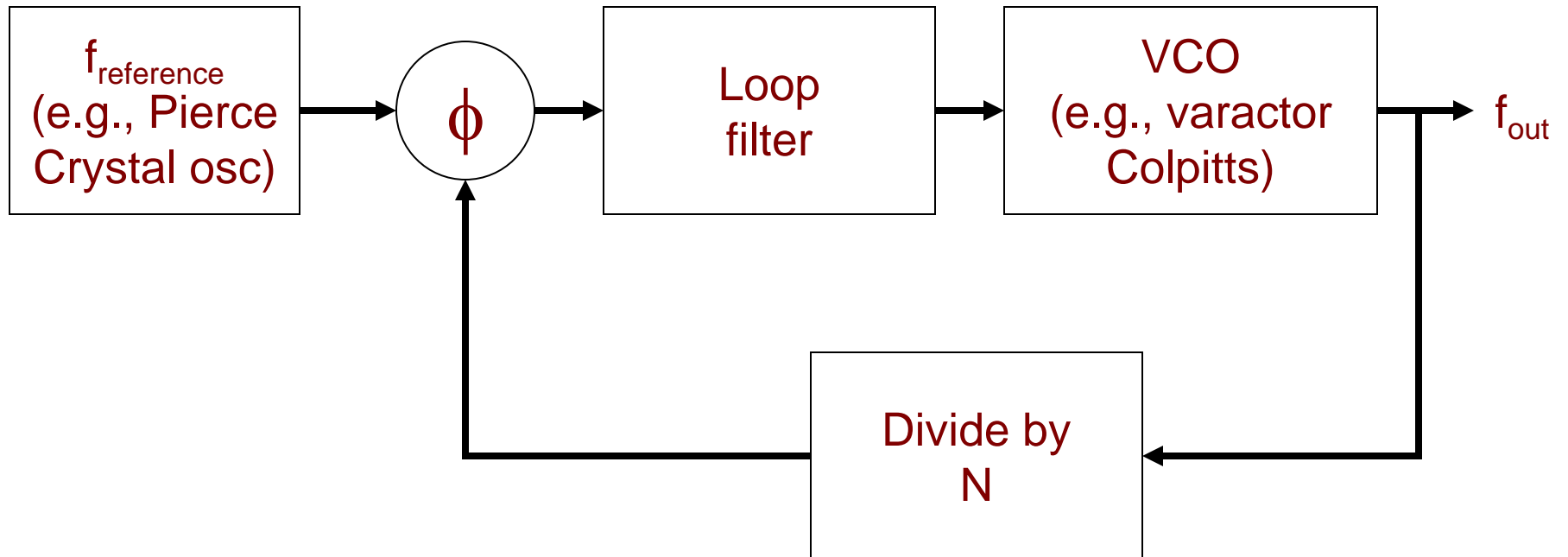

$$f_{\text{out}} = f_{\text{reference}} \cdot N$$

Numerically Controlled Oscillators

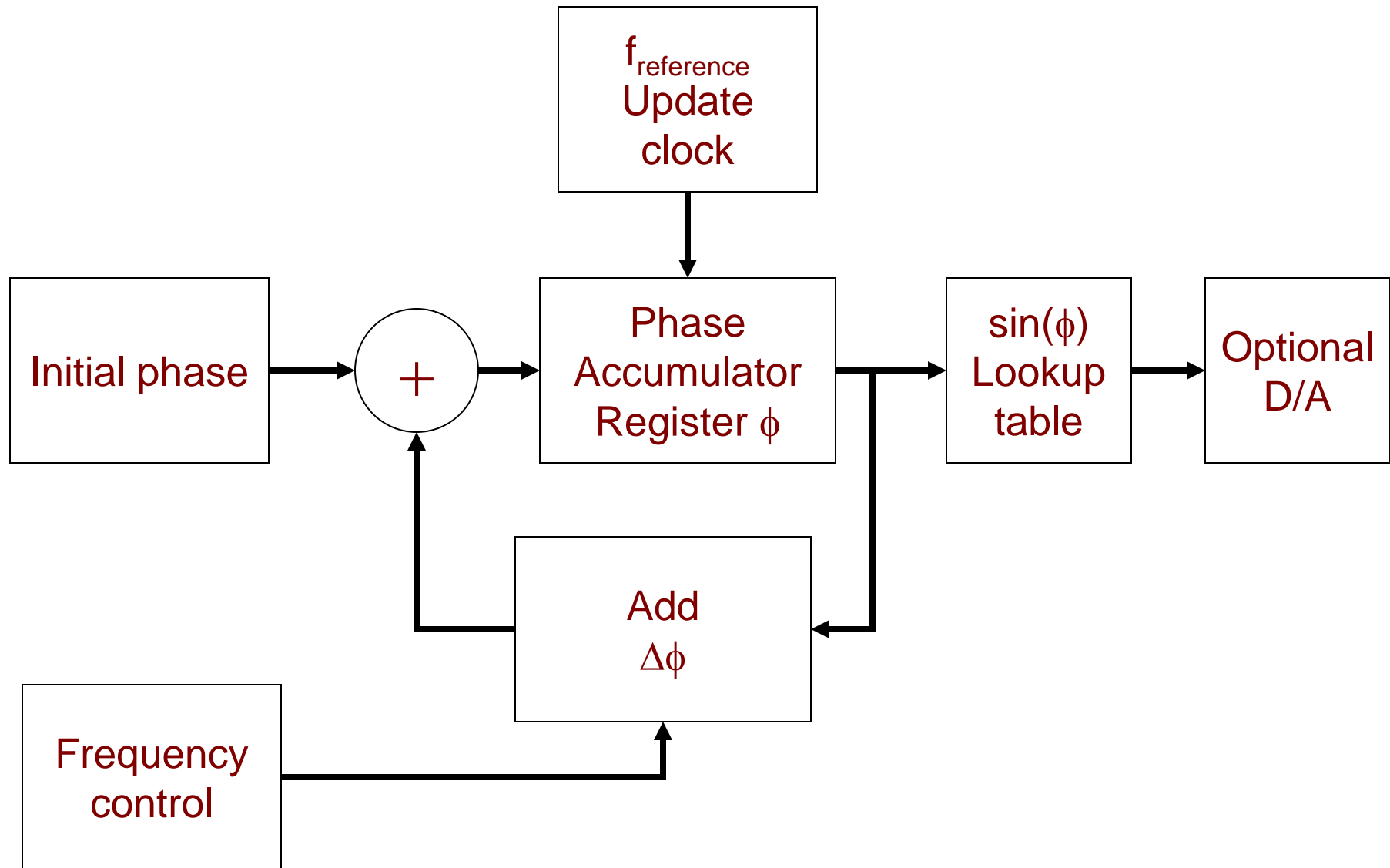

Arbitrary Waveform Generators

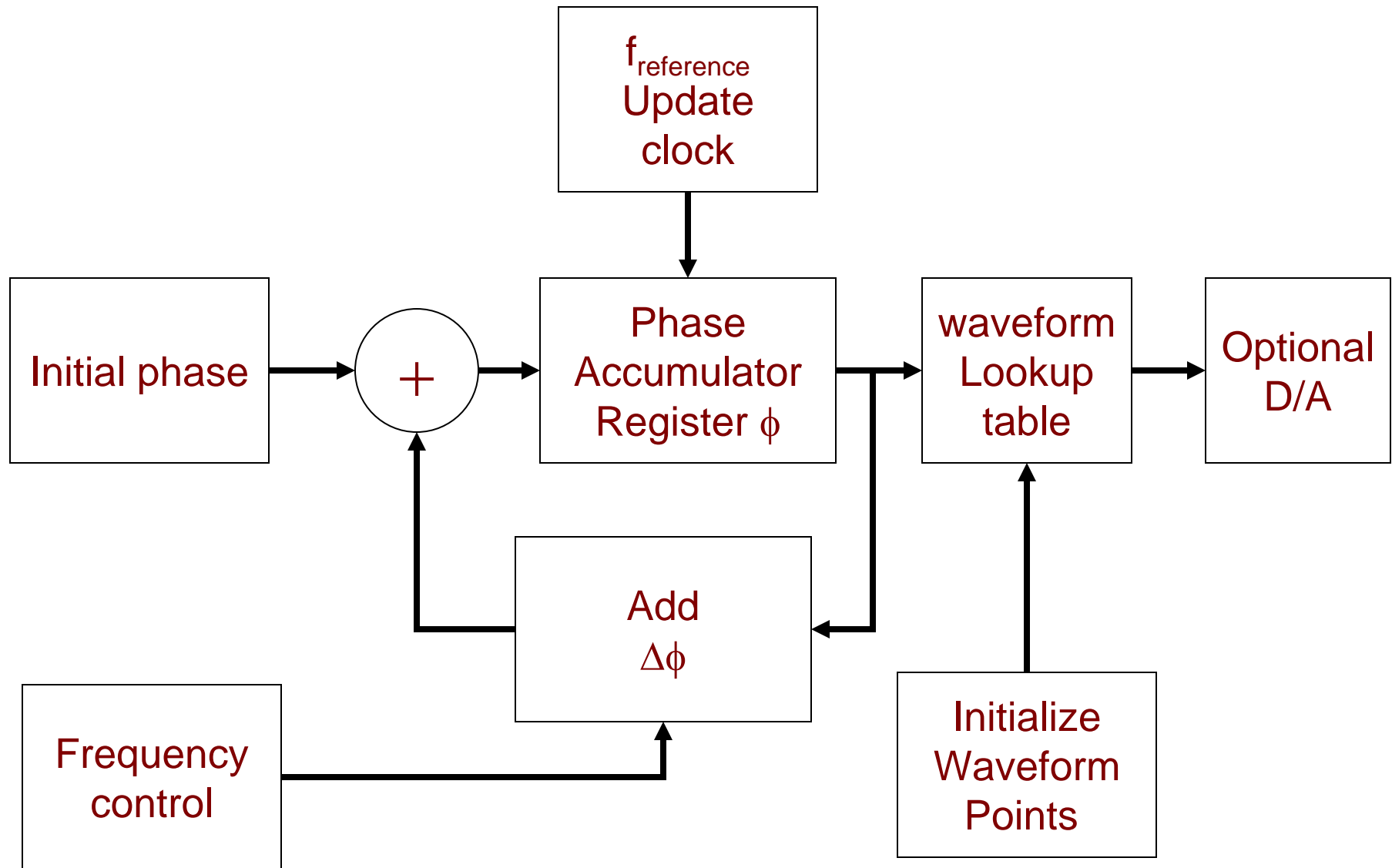

Clock Waveform Generation

