

Design IV

E232 Spring 07

Class 5

Bruce McNair
bmcnair@stevens.edu

Signal Conditioning and Transmission

- Operational Amplifier – inverting amplifier

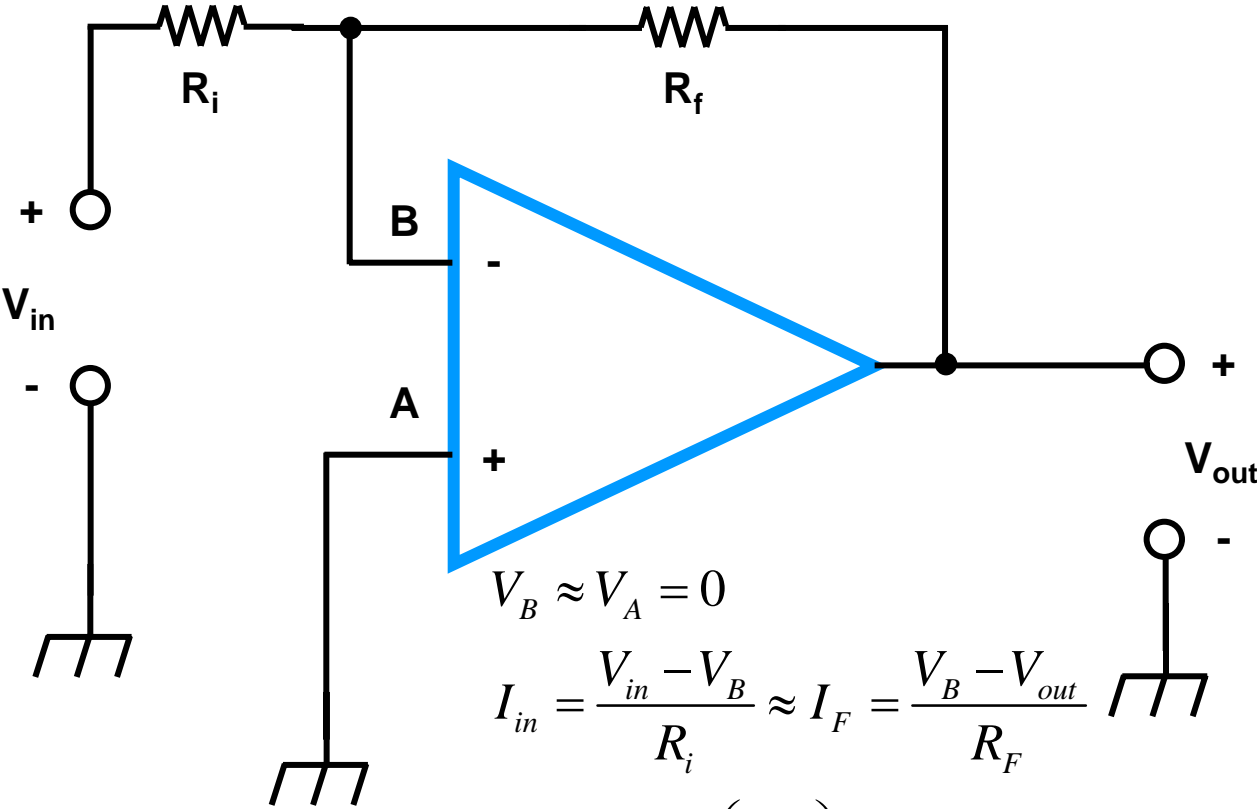

$$V_B \approx V_A = 0$$

$$I_{in} = \frac{V_{in} - V_B}{R_i} \approx I_F = \frac{V_B - V_{out}}{R_F}$$

$$V_{out} \approx -V_{in} \cdot \left(\frac{R_F}{R_i} \right)$$

Signal Conditioning and Transmission

- Operational Amplifiers – Gain Bandwidth Product

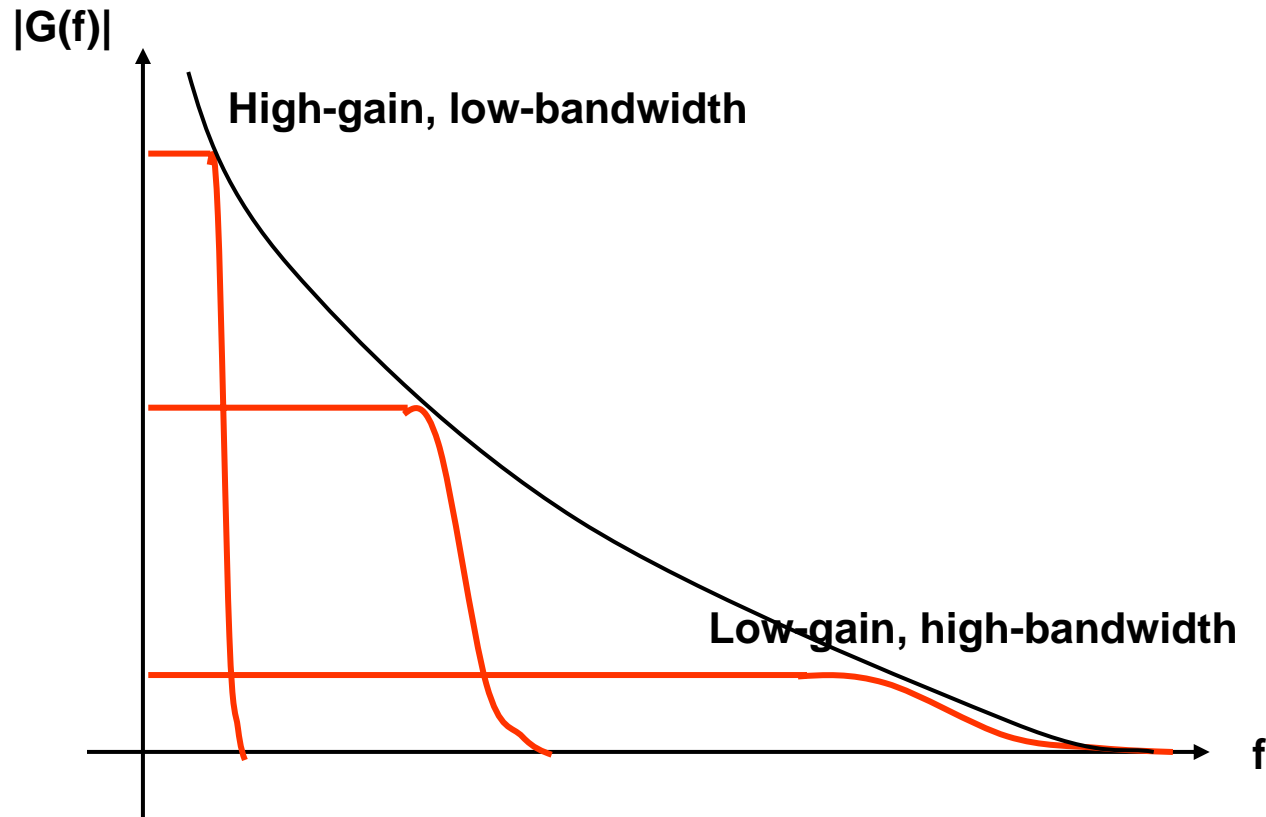

Signal Conditioning and Transmission

- Filter families

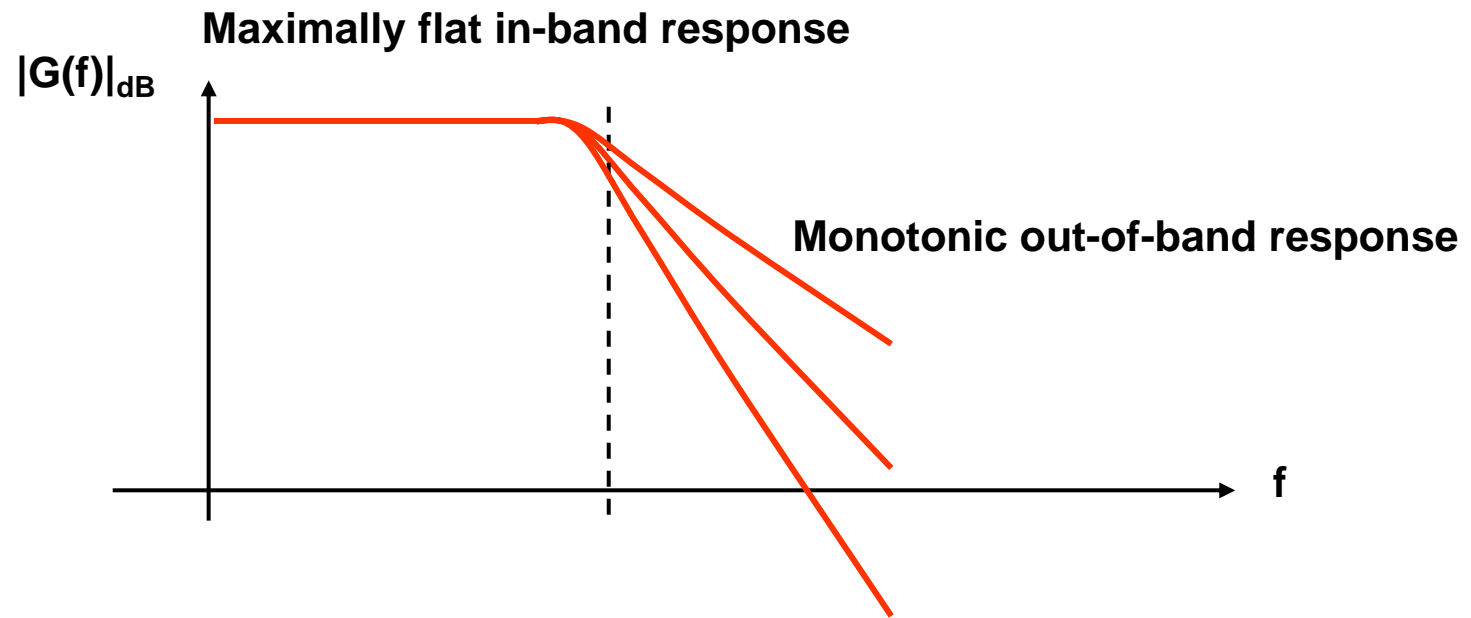

Butterworth

Good phase response

High filter order needed for high out-of-band attenuation

Signal Conditioning and Transmission

- Building filters with op-amps

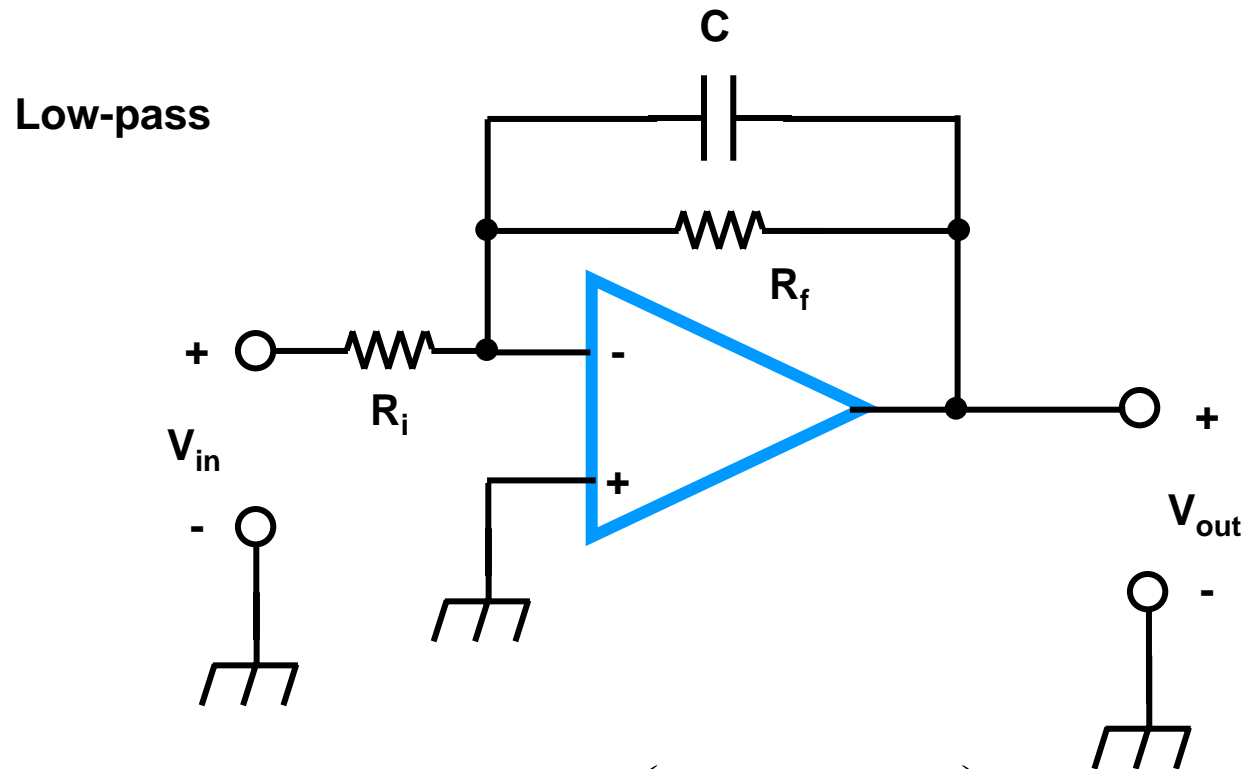

$$G(f) = -\left(\frac{R_f}{R_i}\right) \cdot \left(\frac{1}{1 + j2\pi fCR_f}\right)$$

Signal Conditioning and Transmission

- Building filters with op-amps

High-pass

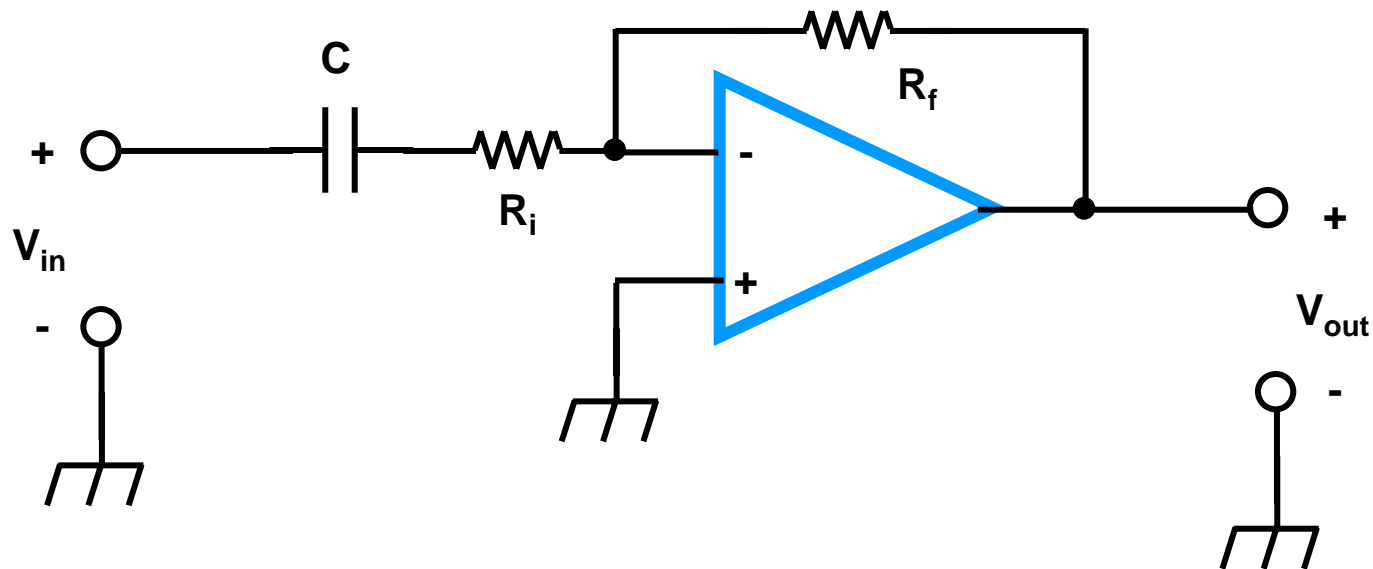

Today's topics

- Signal conditioning, transformation
 - Integration, differentiation, comparison
- Indicators and recording devices
 - Voltage
 - Waveforms
 - Frequency
 - Spectrum

Signal Conditioning and Transmission

- Computing integral and derivative values

$$o(t) = \alpha \cdot a(t)$$

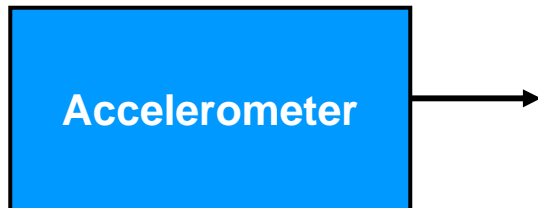

Signal Conditioning and Transmission

- Computing integral and derivative values

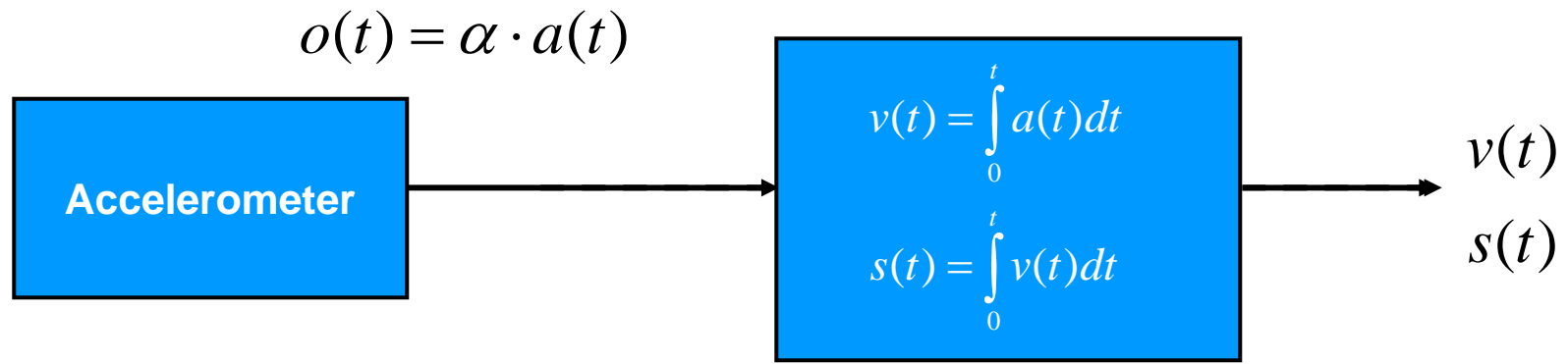

Signal Conditioning and Transmission

- Computing integral and derivative values

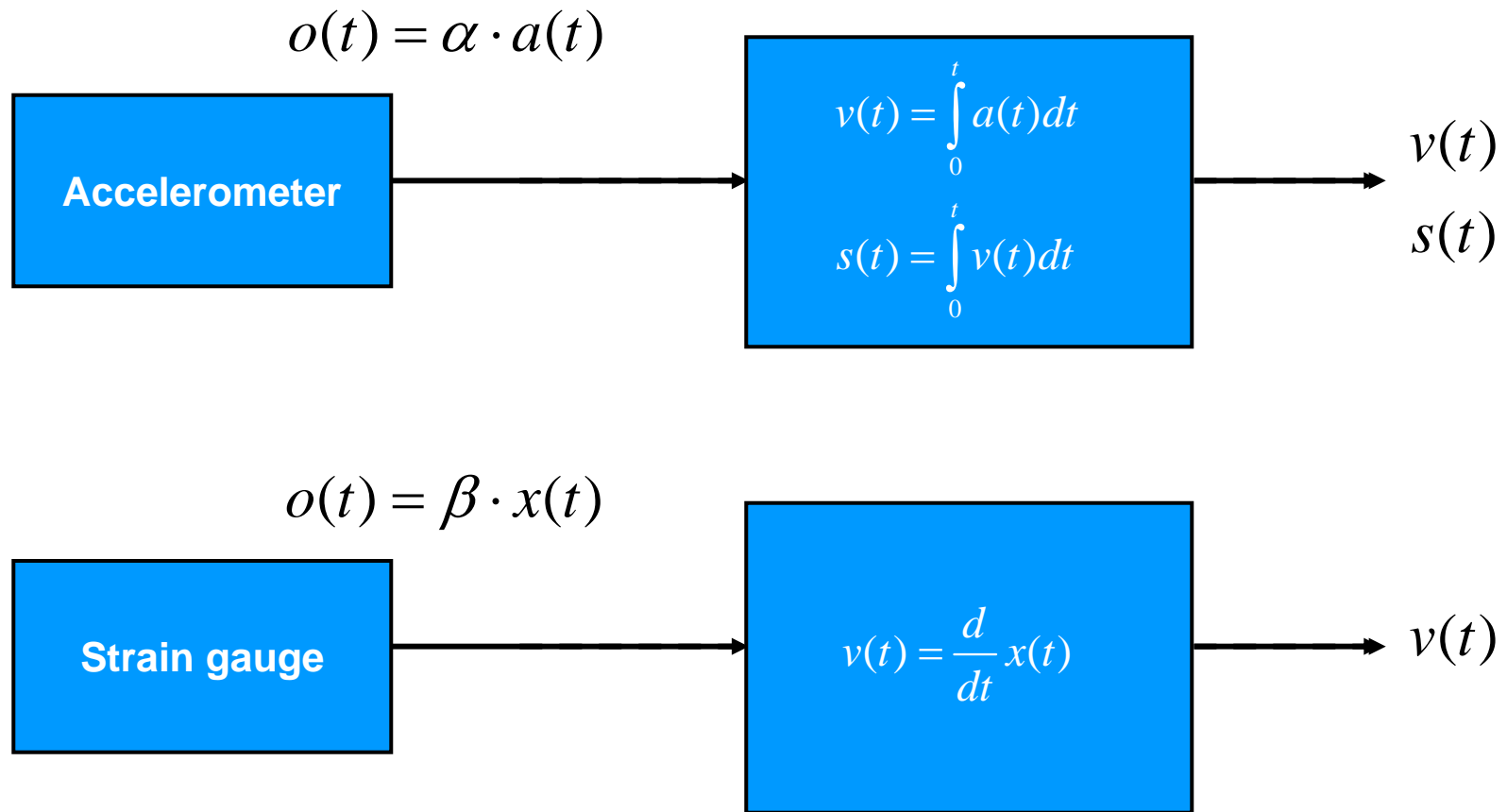

Signal Conditioning and Transmission

- Differentiator

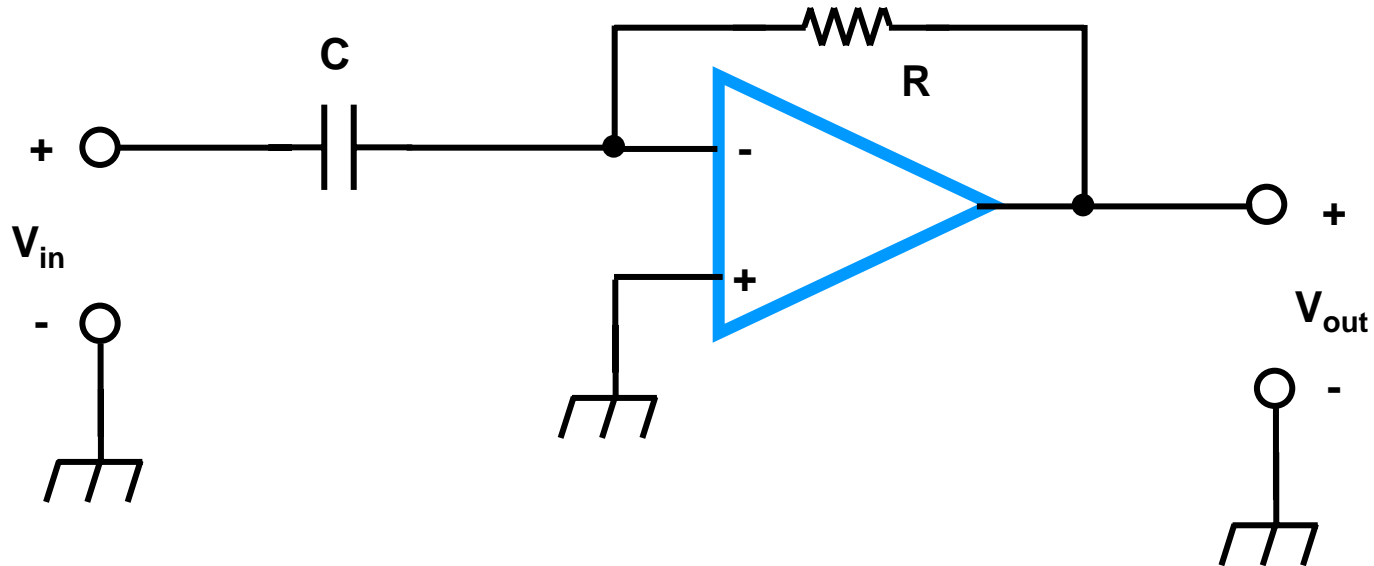

$$V_{out}(t) = -RC \frac{d}{dt} V_{in}(t)$$

Signal Conditioning and Transmission

- Integrator

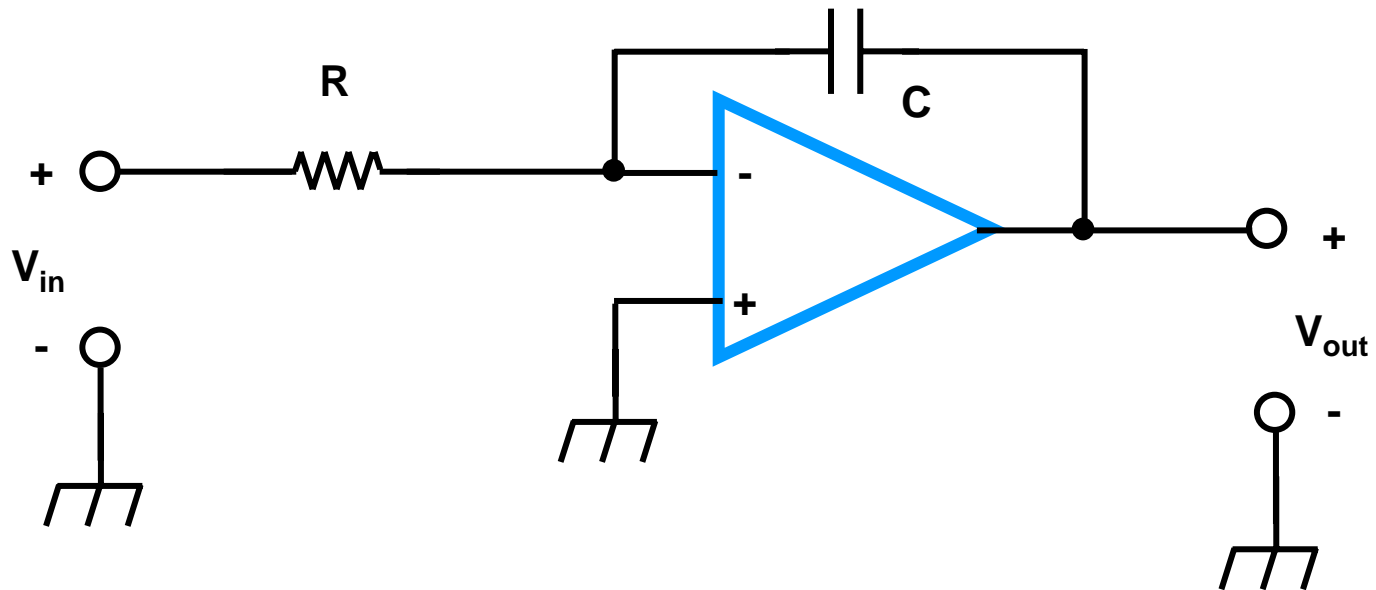

$$V_{out}(t) = V_{out}(0) - \frac{1}{RC} \int_0^t V_{in}(t) dt$$

Signal Conditioning and Transmission

- Comparator

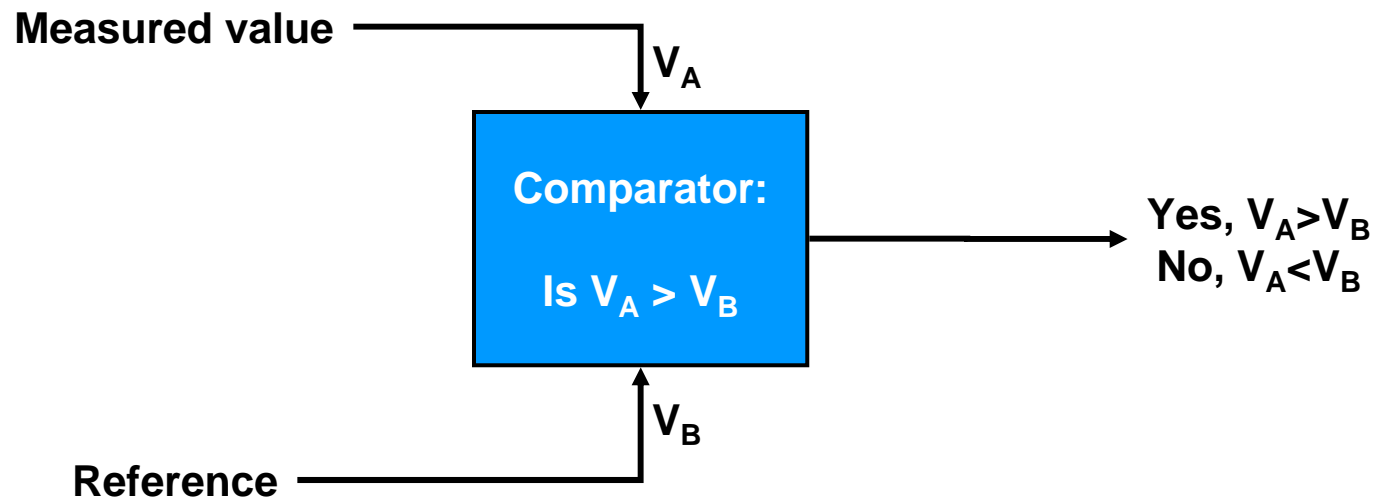

Signal Conditioning and Transmission

- Comparator

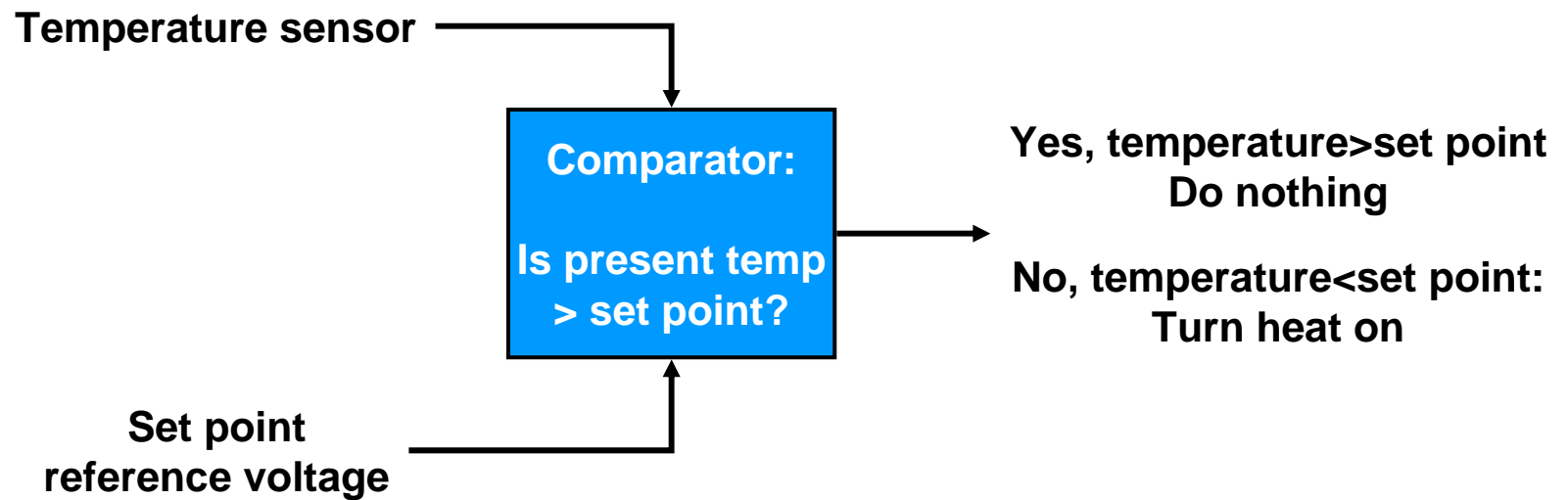

Signal Conditioning and Transmission

- Comparator

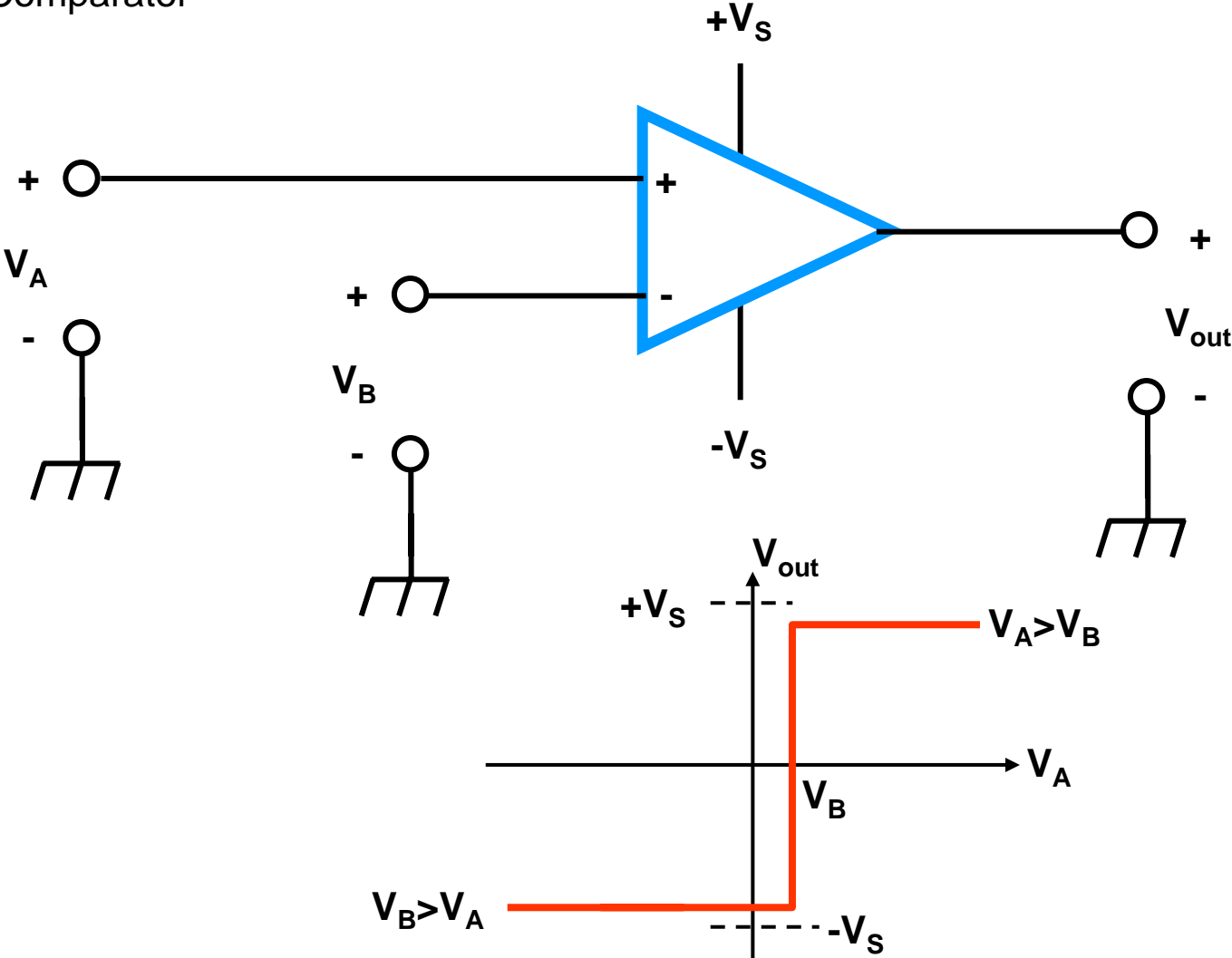

Recorders/Indicators

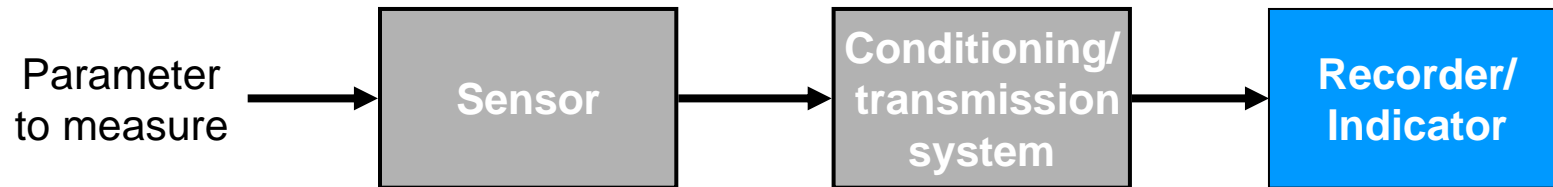

Recorders/Indicators

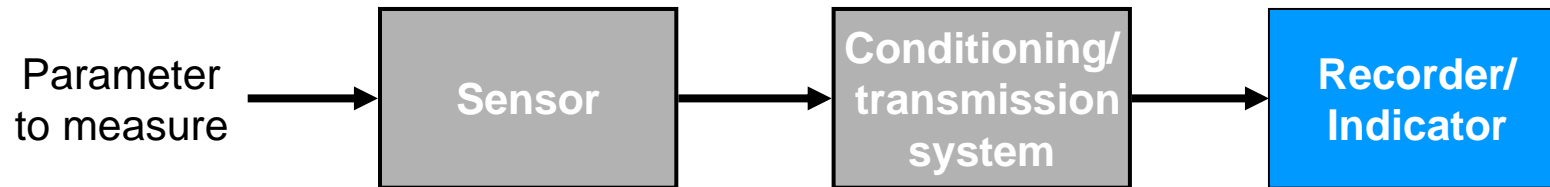

Static/slowly varying signals:

- **Voltage**
- **Current**
- **Resistance**

Dynamic signals:

- **Time Domain (waveforms)**
- **Frequency domain (spectra)**

Recorders/Indicators

- Classical voltage (current) measurement

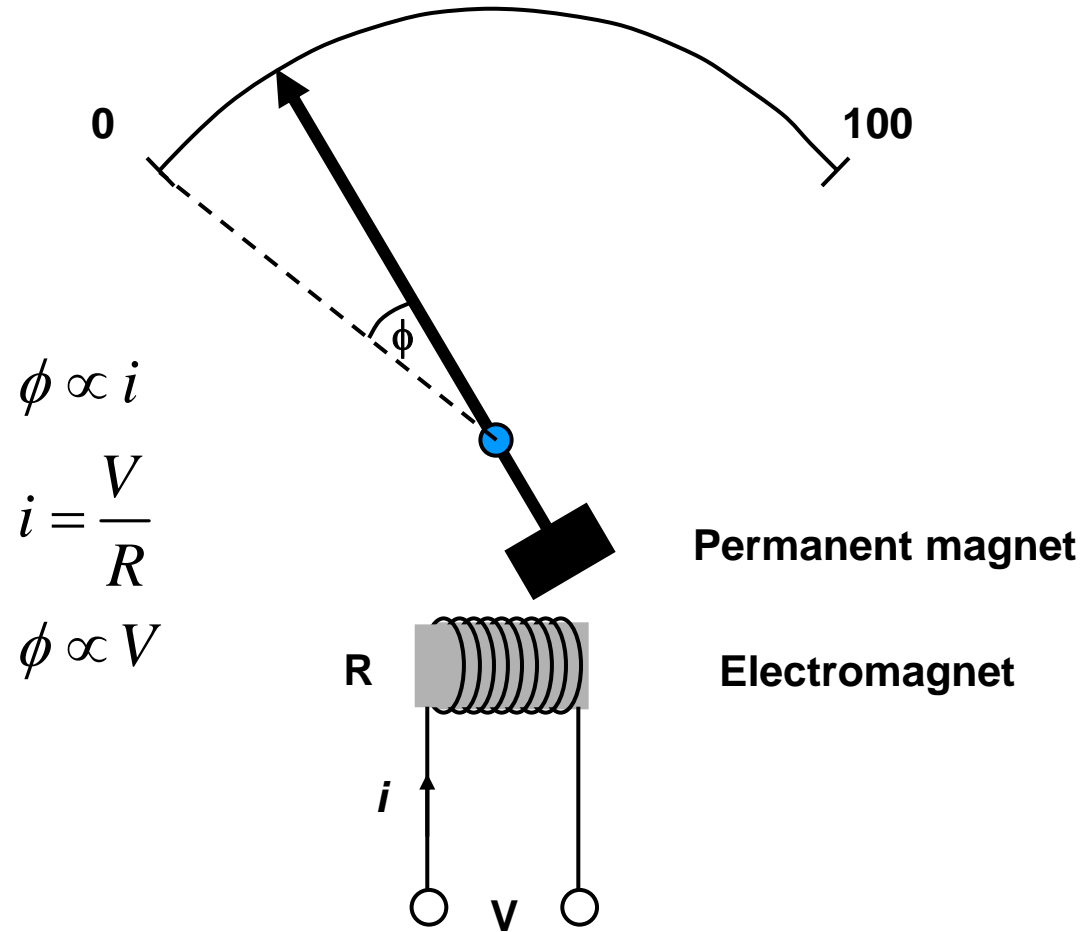

Recorders/Indicators

- Classical voltage (current) recorder

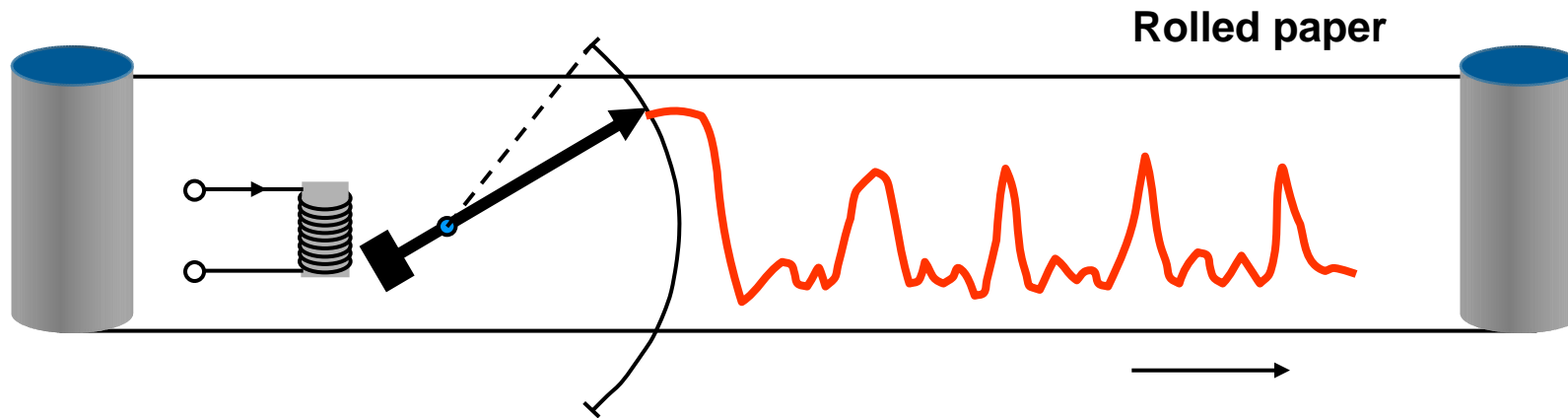

- **Seismic indicators**
- **EKG monitors**
- **Polygraph machines**

Recorders/Indicators

- Classical resistance measurement

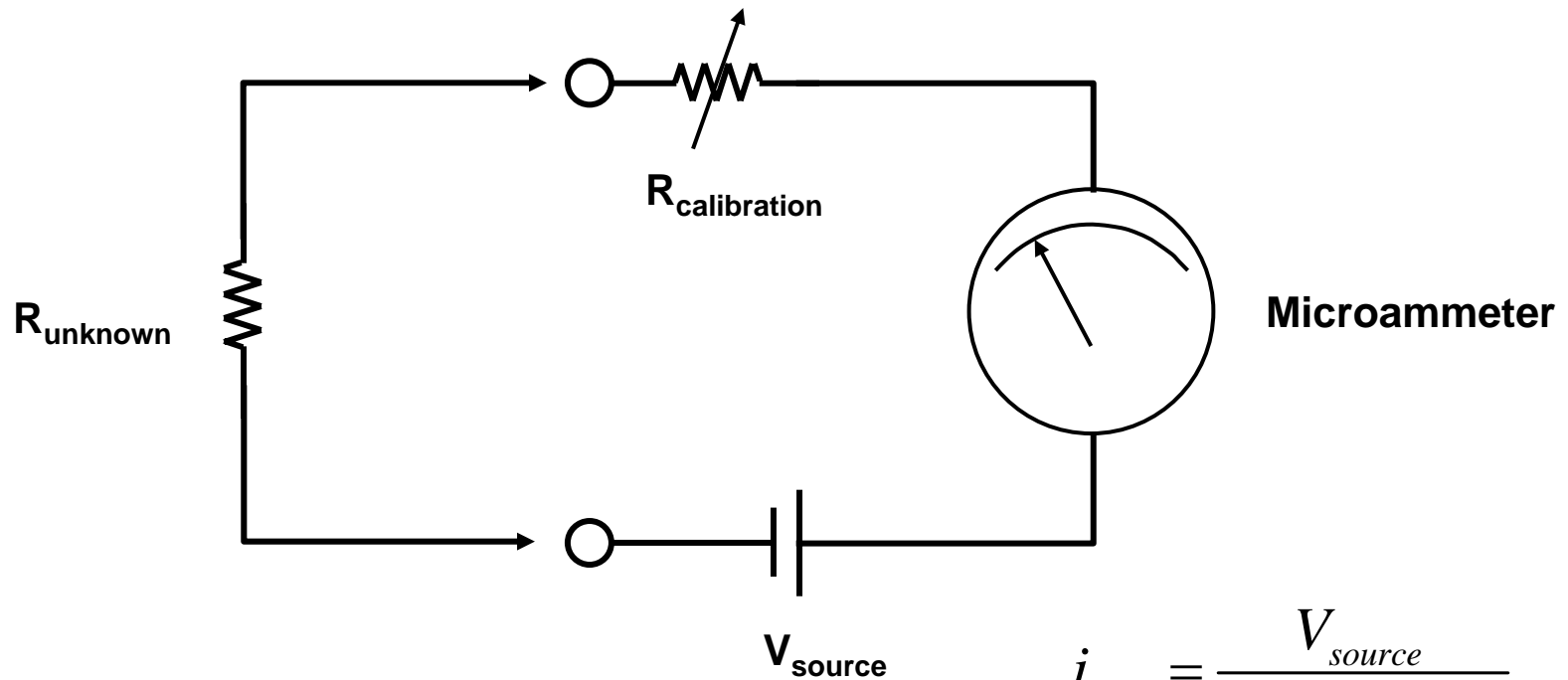

$$i_{\text{max}} = \frac{V_{\text{source}}}{R_{\text{calibration}} + 0}$$

$$i = \frac{V_{\text{source}}}{R_{\text{calibration}} + R_{\text{unknown}}}$$

Recorders/Indicators

- Modern voltage, current measurements

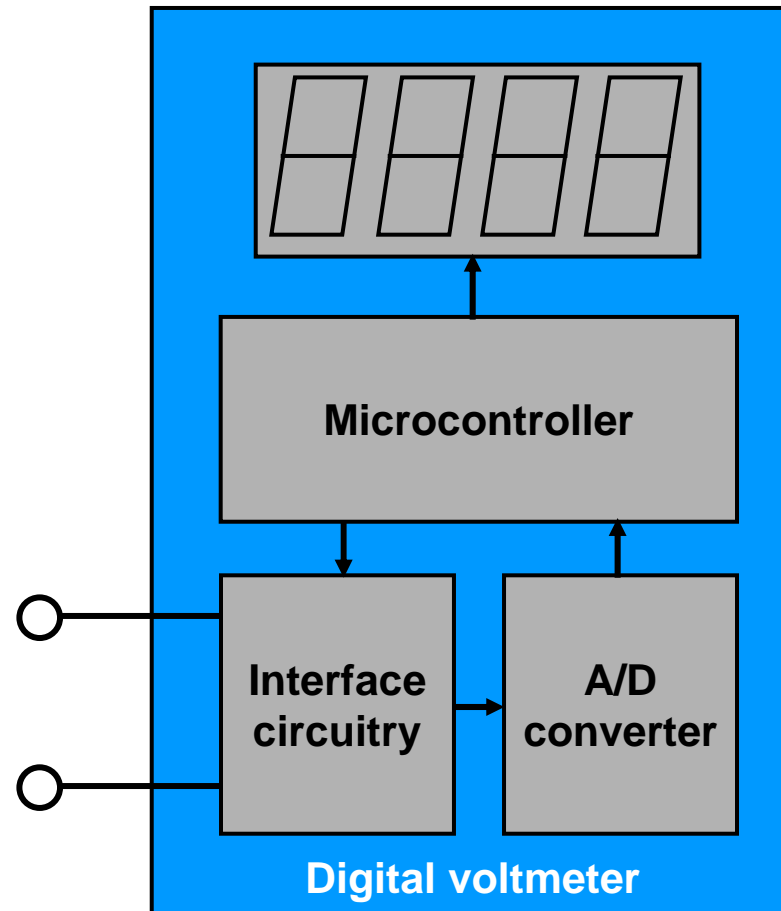

Recorders/Indicators

- Modern voltage, current measurements

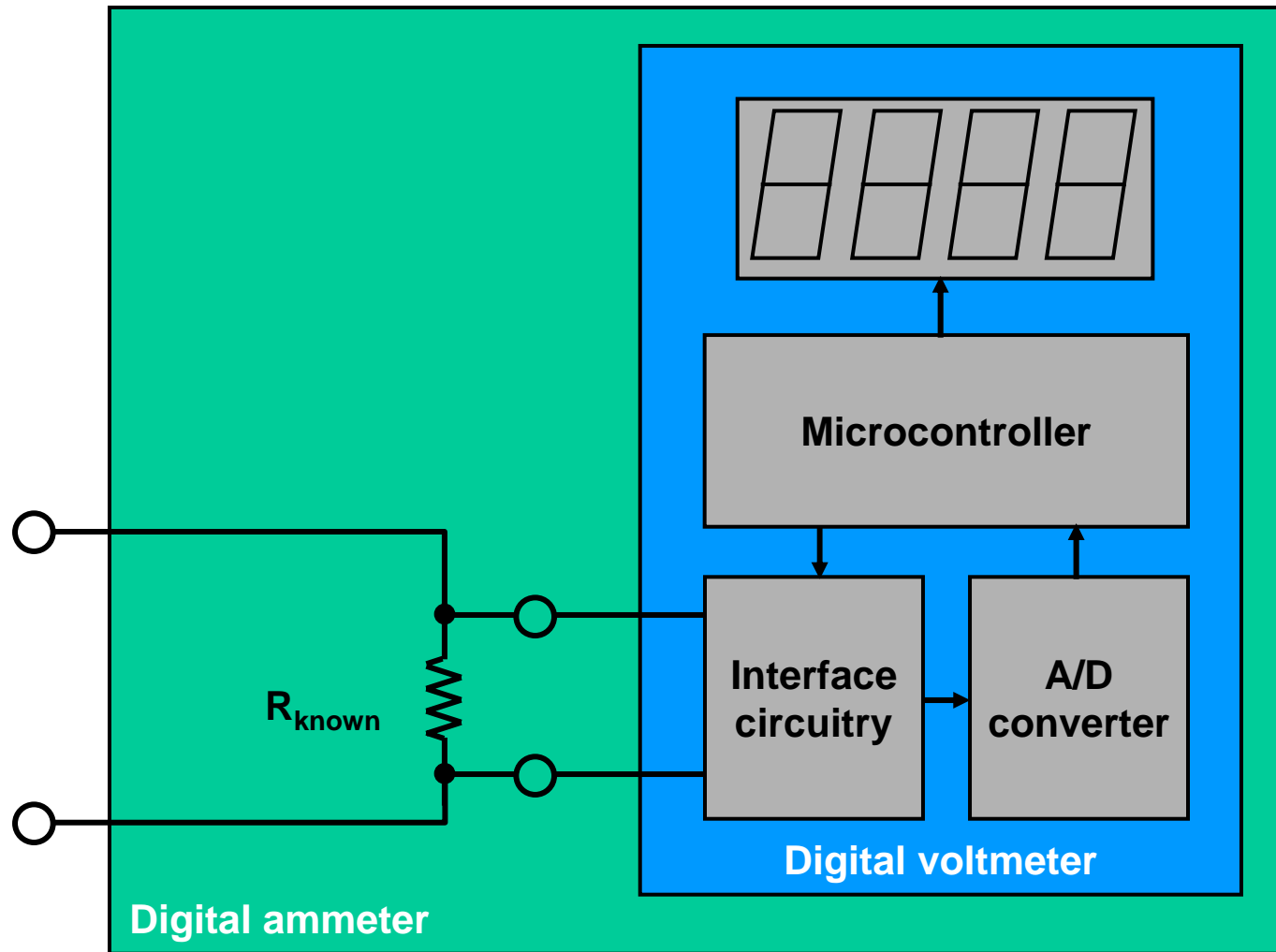

Recorders/Indicators

- Dynamic signal measurements – waveform displays

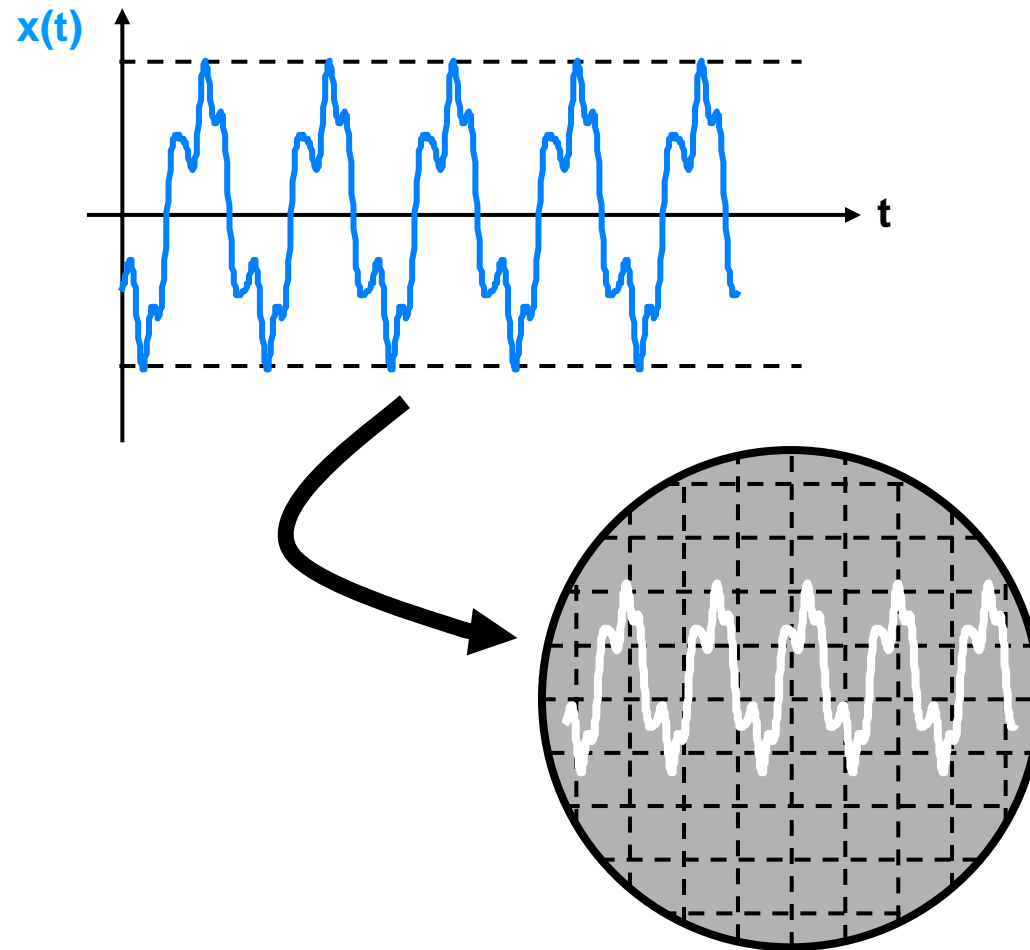

Recorders/Indicators

- Dynamic signal measurements – waveform displays

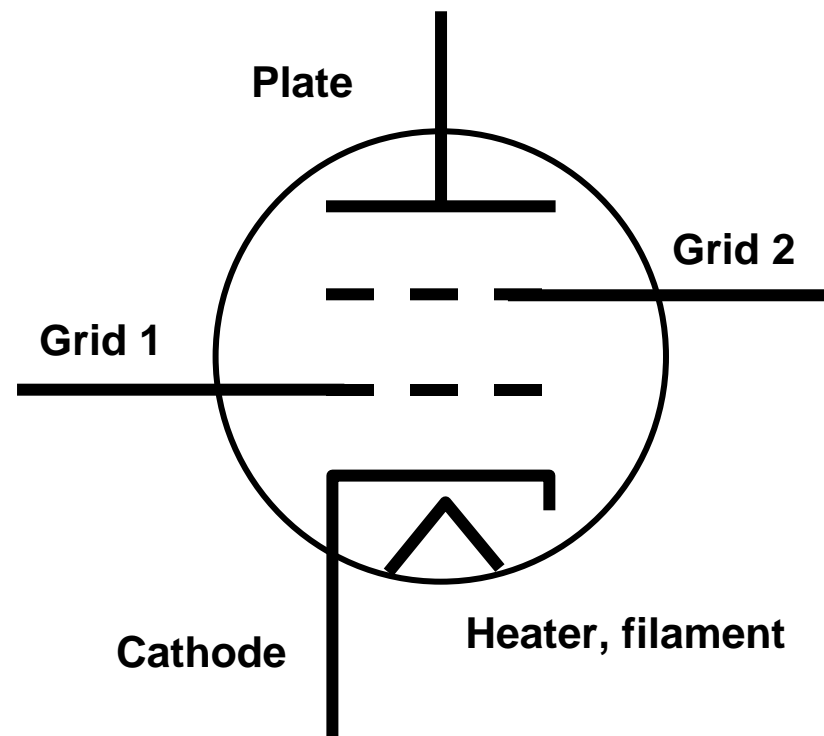

Recorders/Indicators

- Dynamic signal measurements – waveform displays

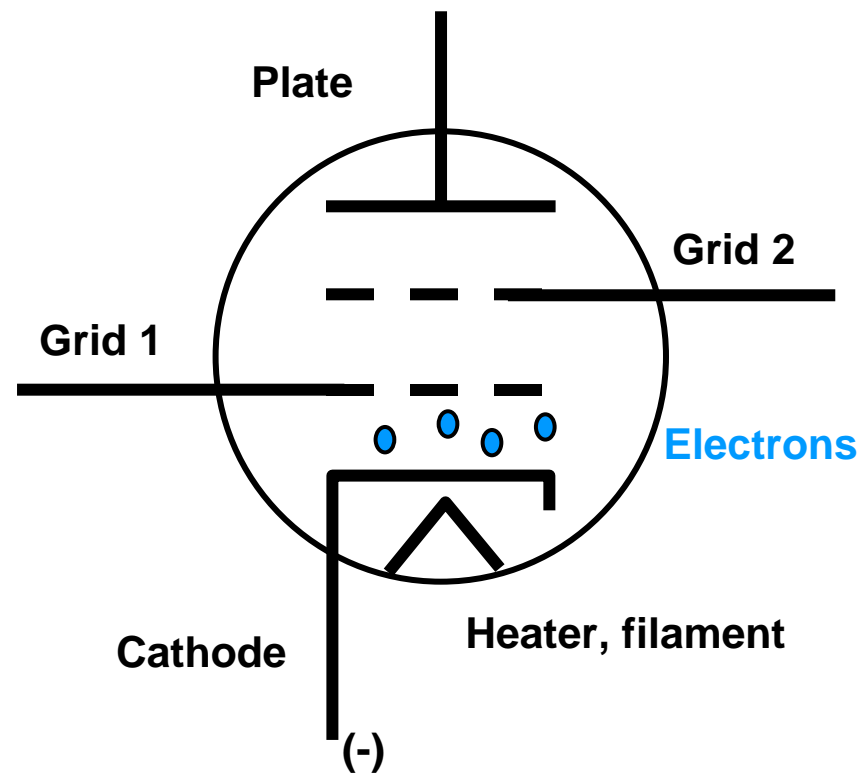

Recorders/Indicators

- Dynamic signal measurements – waveform displays

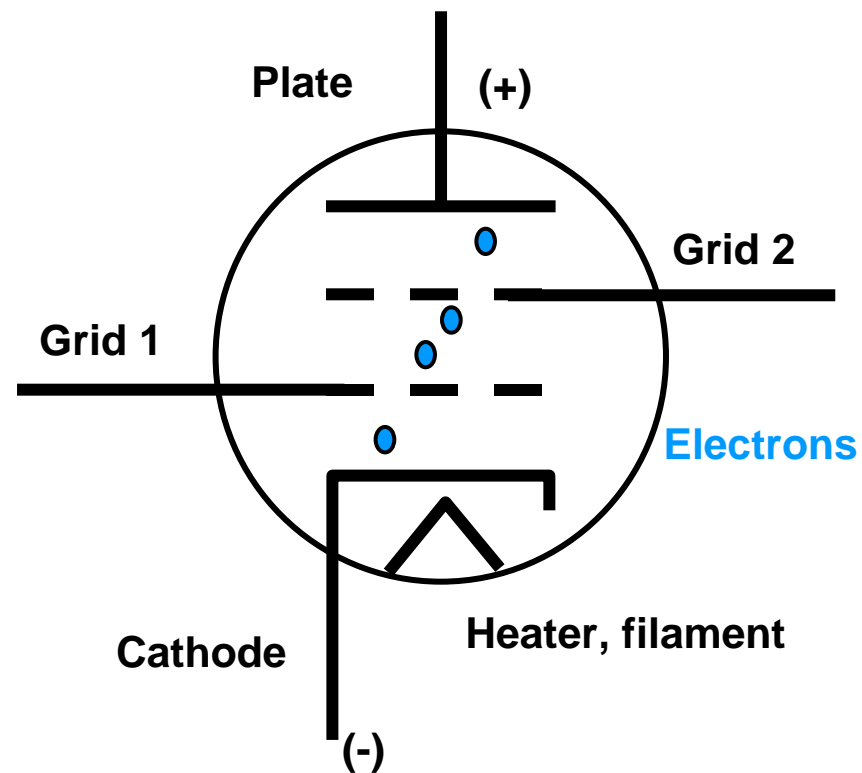

Recorders/Indicators

- Dynamic signal measurements – waveform displays

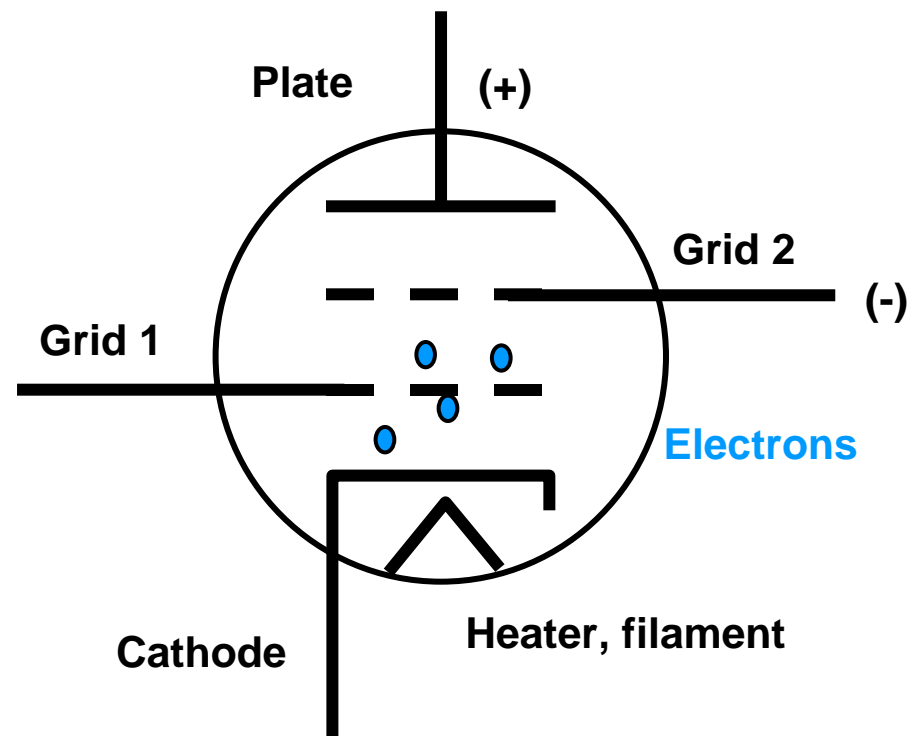

Recorders/Indicators

- Dynamic signal measurements – waveform displays: oscilloscope

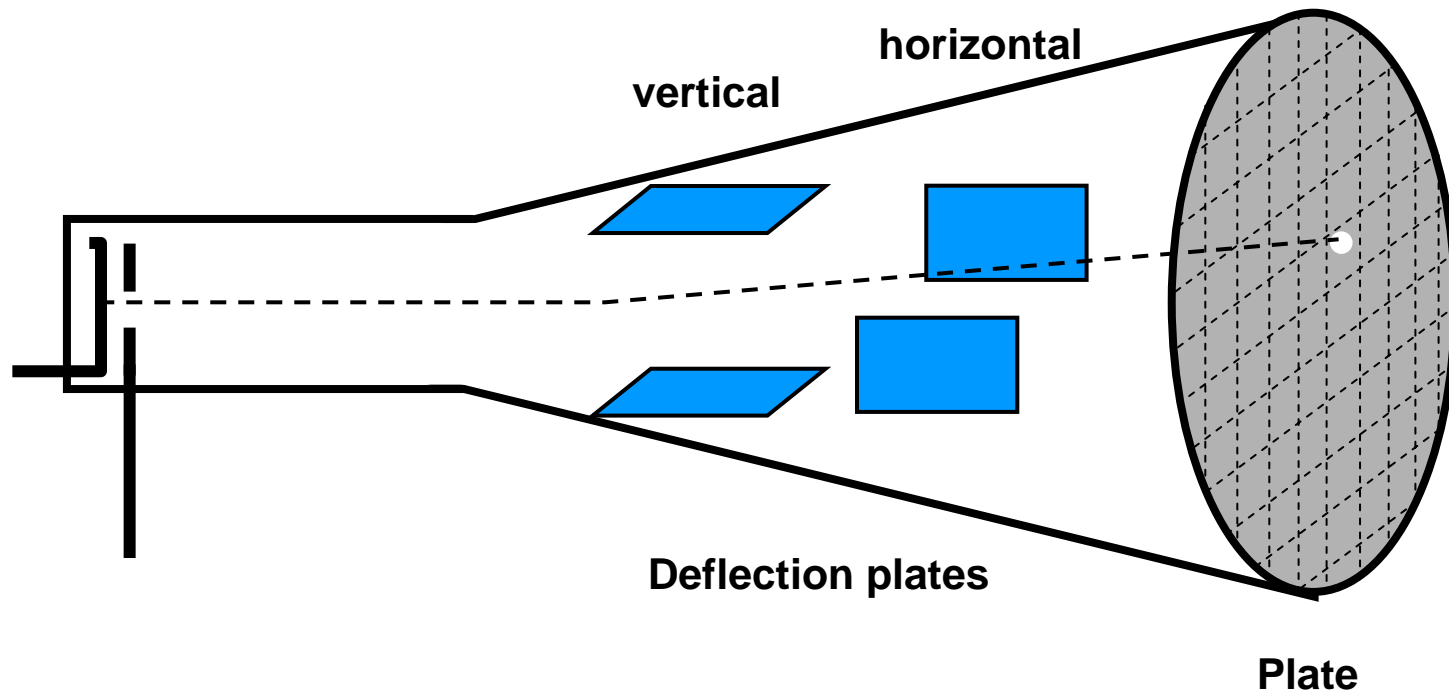

Recorders/Indicators

- Dynamic signal measurements – waveform displays: oscilloscope

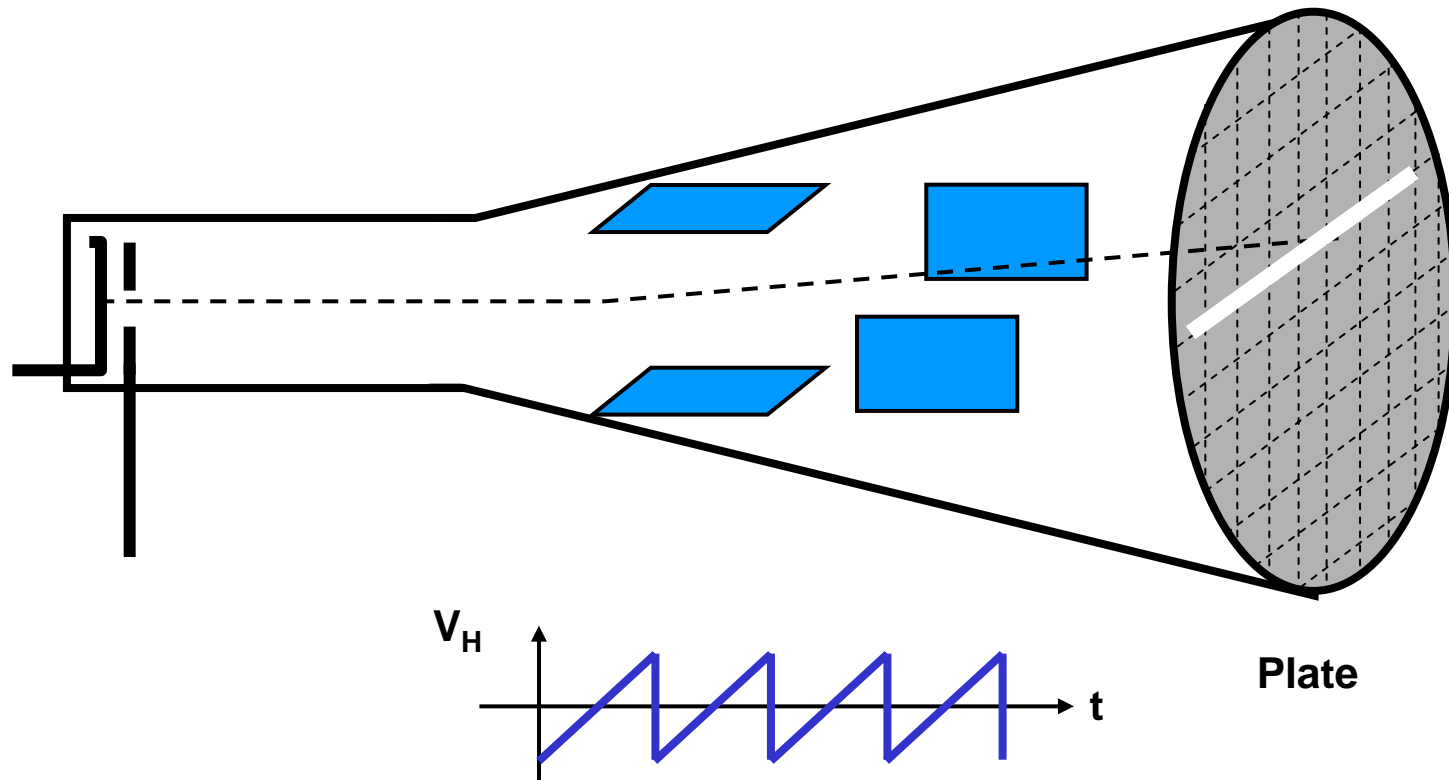

Recorders/Indicators

- Dynamic signal measurements – waveform displays: oscilloscope

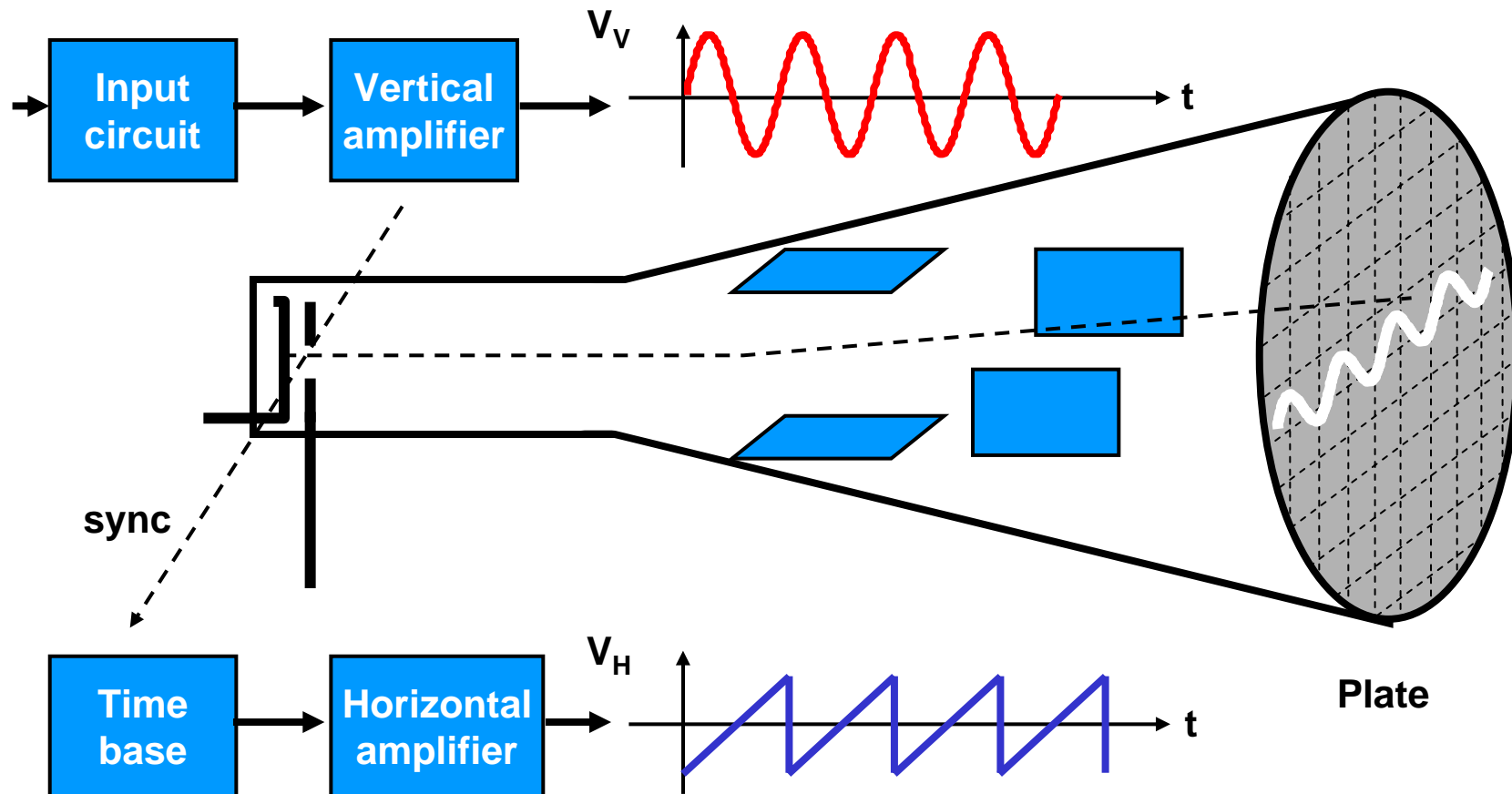

Recorders/Indicators

- Dynamic signal measurements – spectral displays

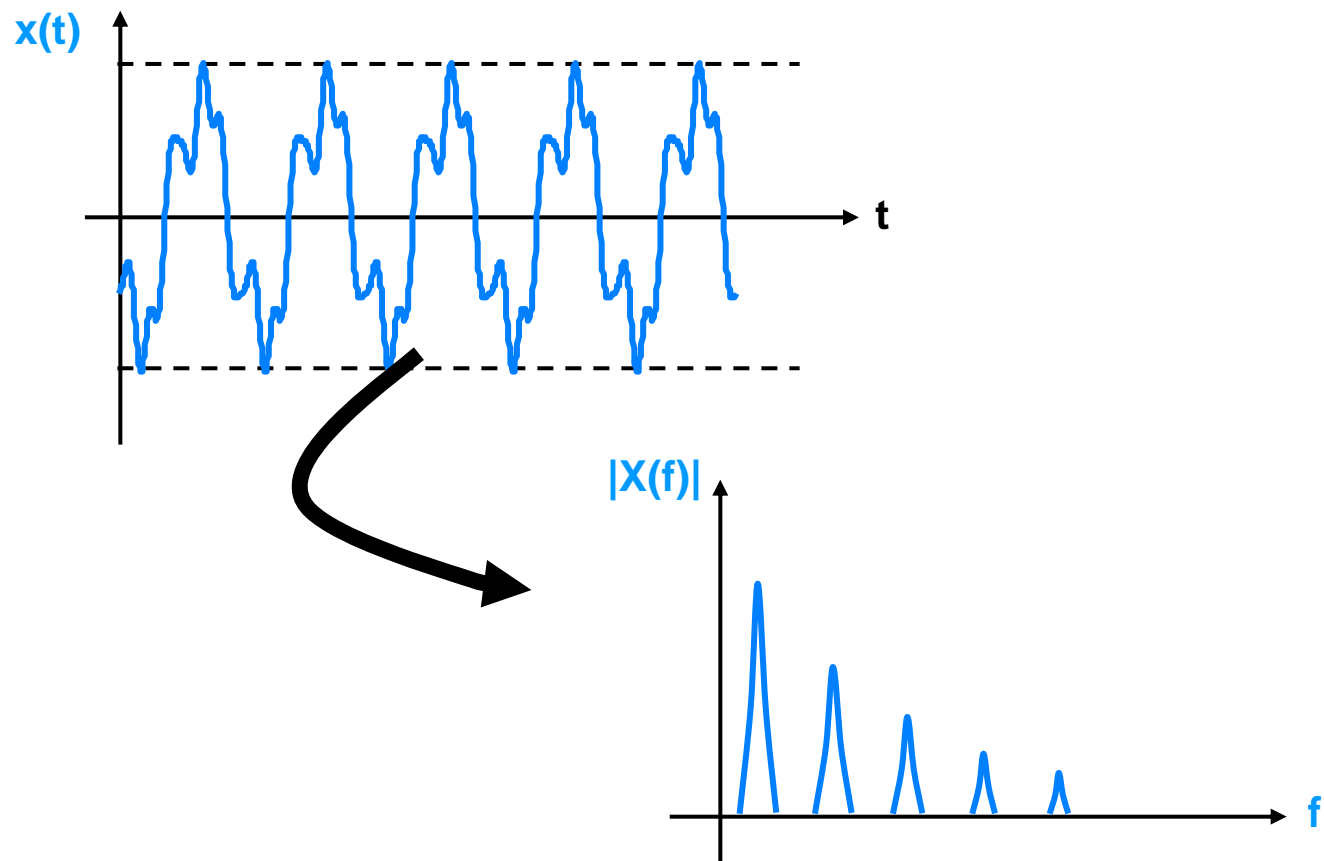

Recorders/Indicators

- Dynamic signal measurements – spectral displays: spectrum analyzer

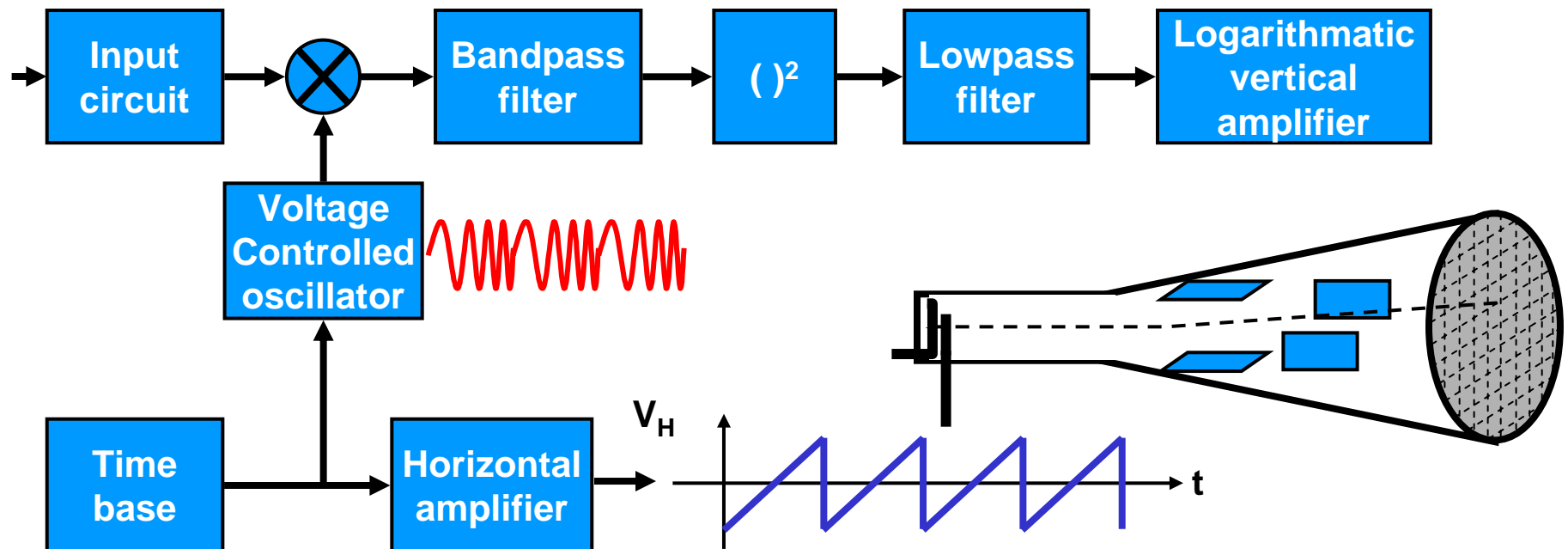

Recorders/Indicators

- Dynamic signal measurements – spectral displays: FFT spectrum analyzer

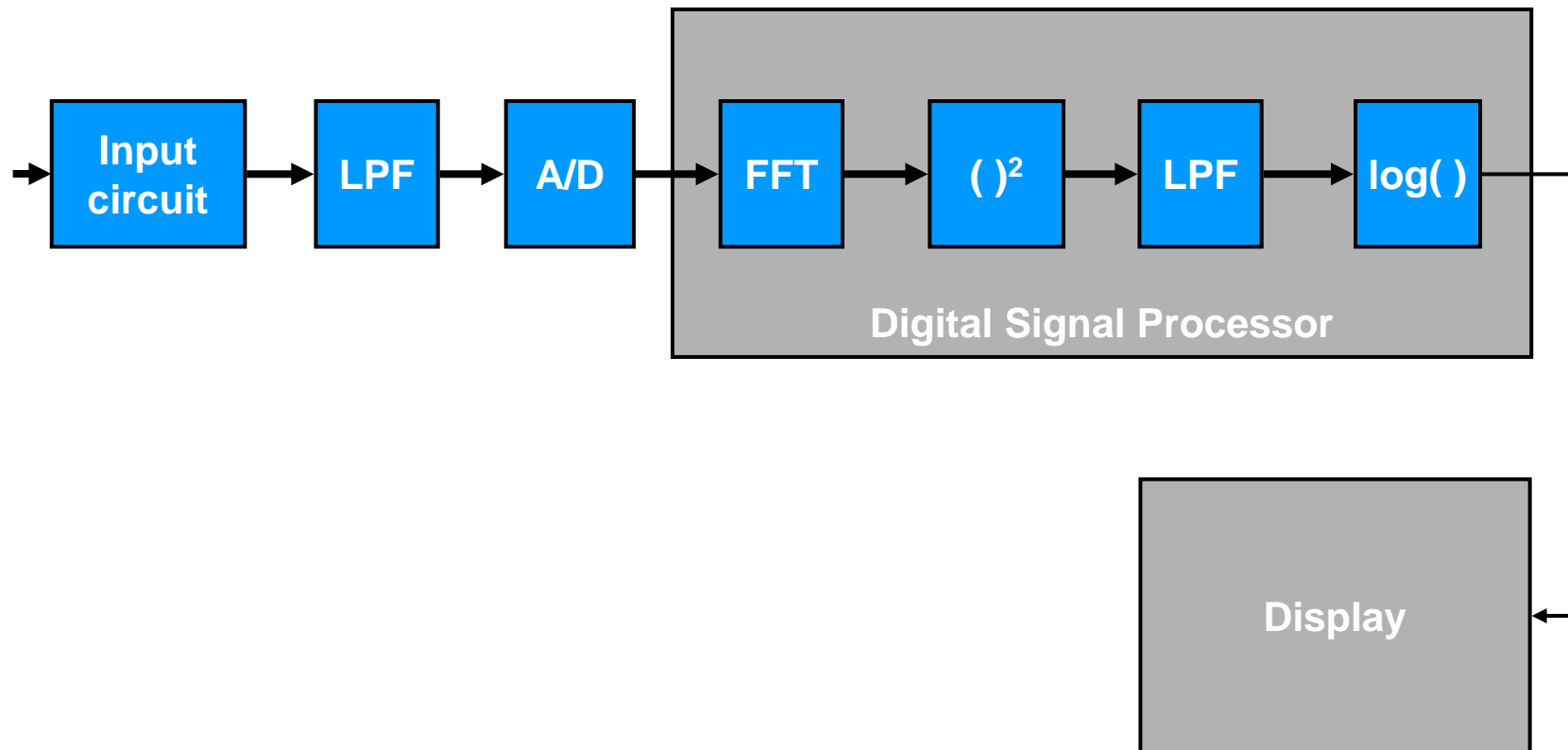

Next topics

- Transmission
 - Signal level considerations
 - Interference sources
 - Ground loops
 - Rationale for digital signal transmission
- Computerized Data Acquisition
 - Signal representation
 - Components
 - A/D conversion
 - Sampling
 - Quantization effects
 - Fourier Transform and frequency domain analysis