

# Design IV

## E232 Spring 07

Class 3

Bruce McNair  
bmcnair@stevens.edu

# Measurement Systems

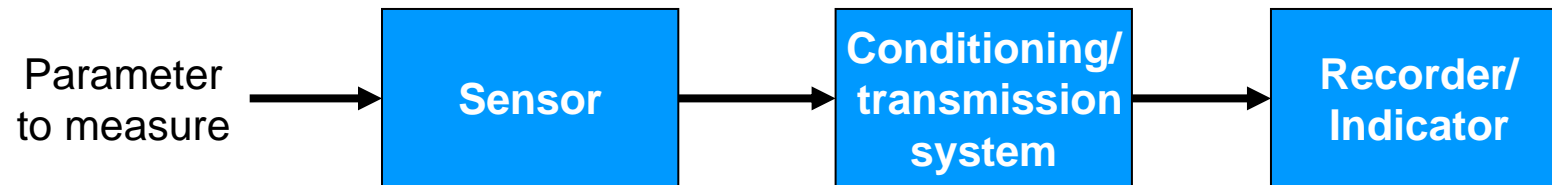

# Measurement Systems

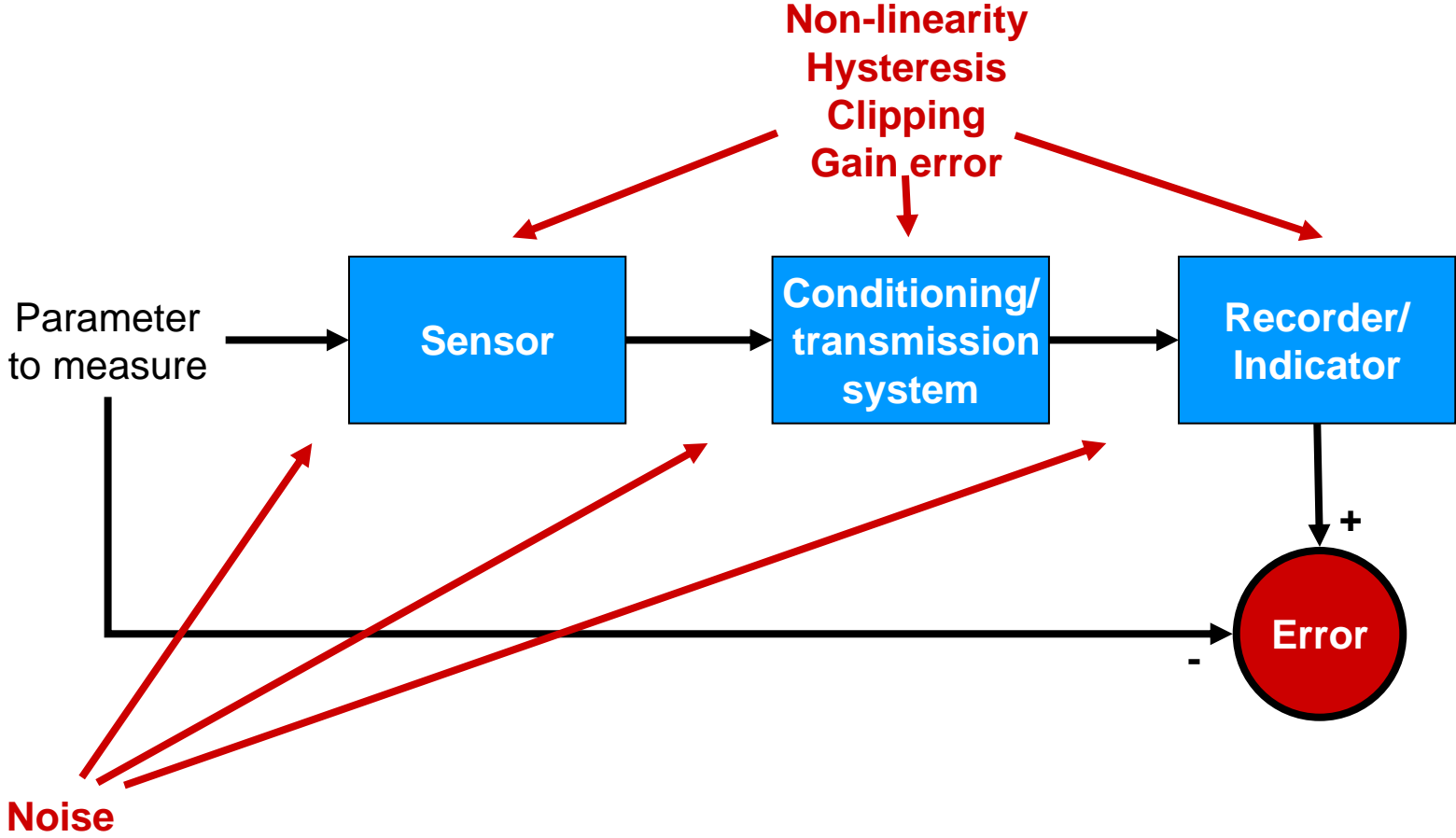

# Dynamic Systems

- Second-order system performance measures

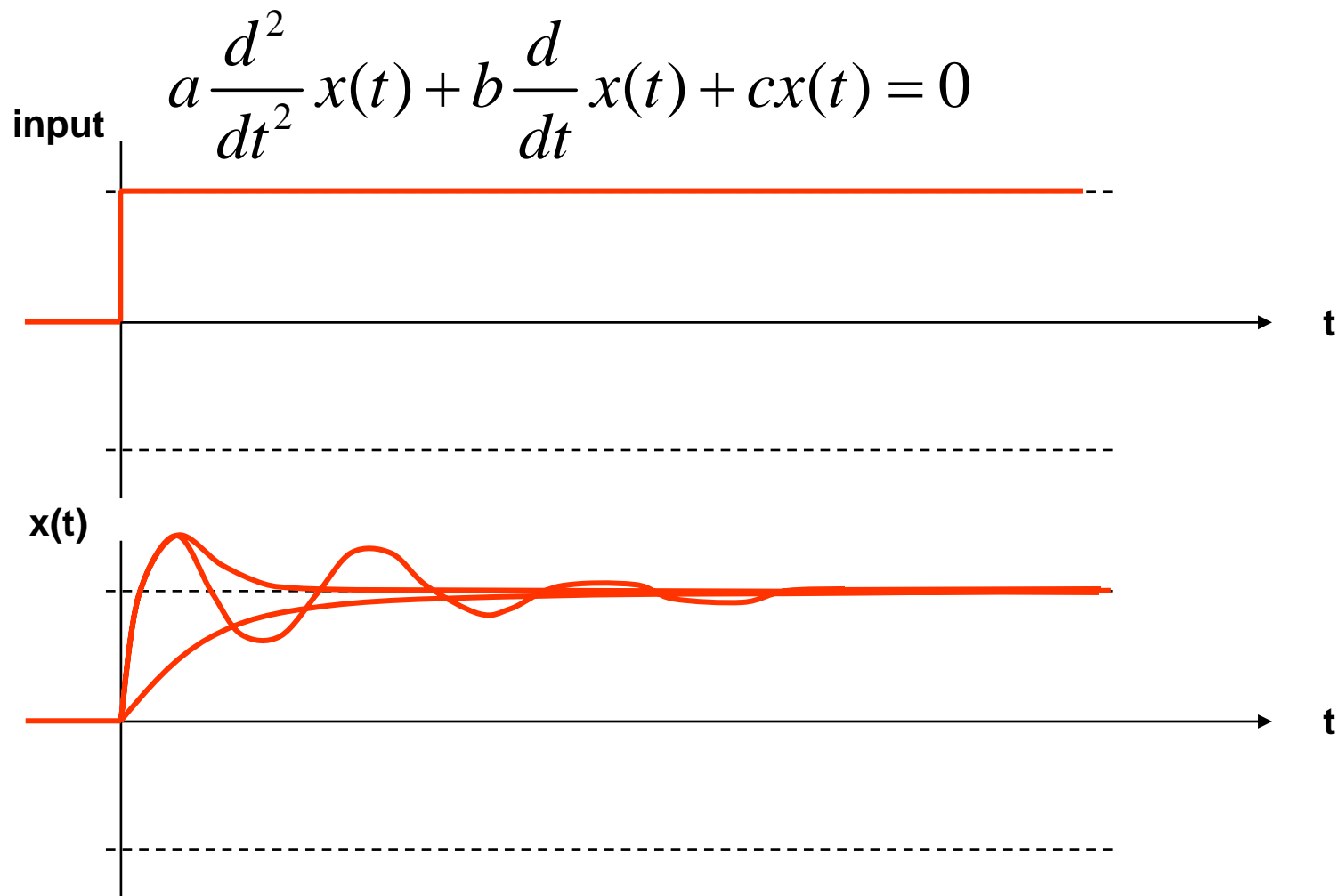

# Frequency Response

- Practical low-pass response

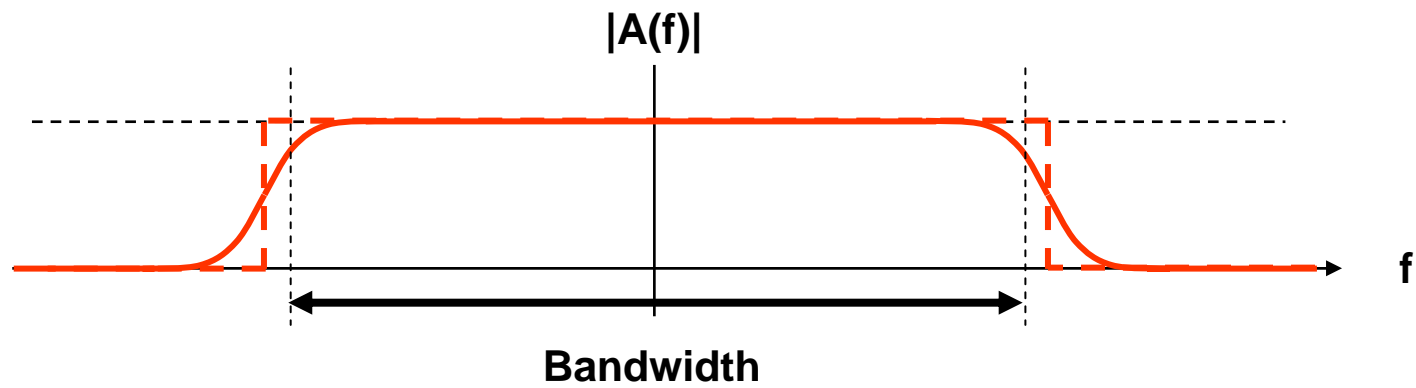

# Today's topics

- Why deal with electrical signals?
- Signal conditioning, transformation
  - Amplifiers
    - Gain
    - Bandwidth
    - Phase shift
    - Common mode rejection

# Electrical Signals In a Physical World

- Most parameters we want to sense and record have physical values

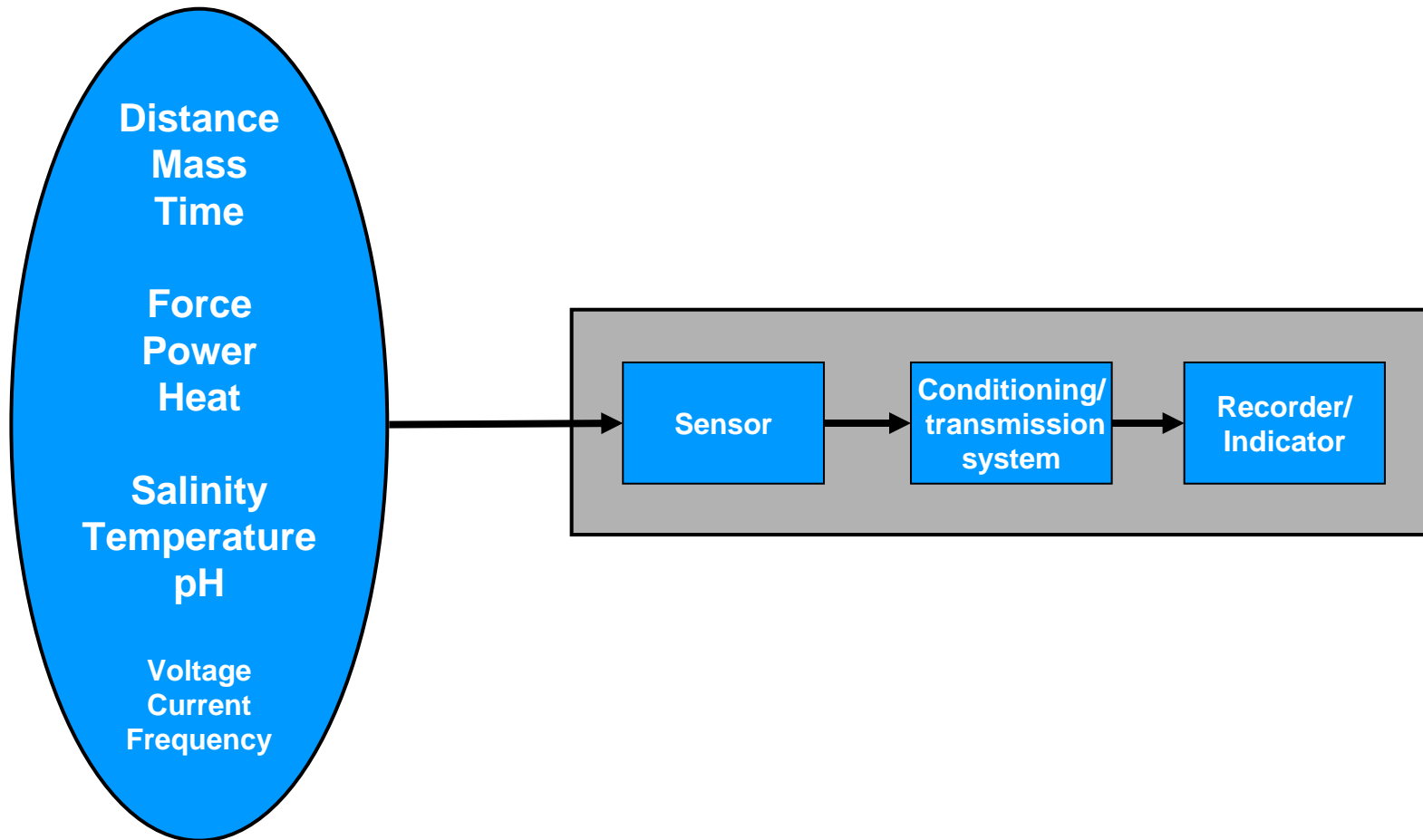

# Electrical Signals In a Physical World

- Most parameters we want to sense and record have physical values

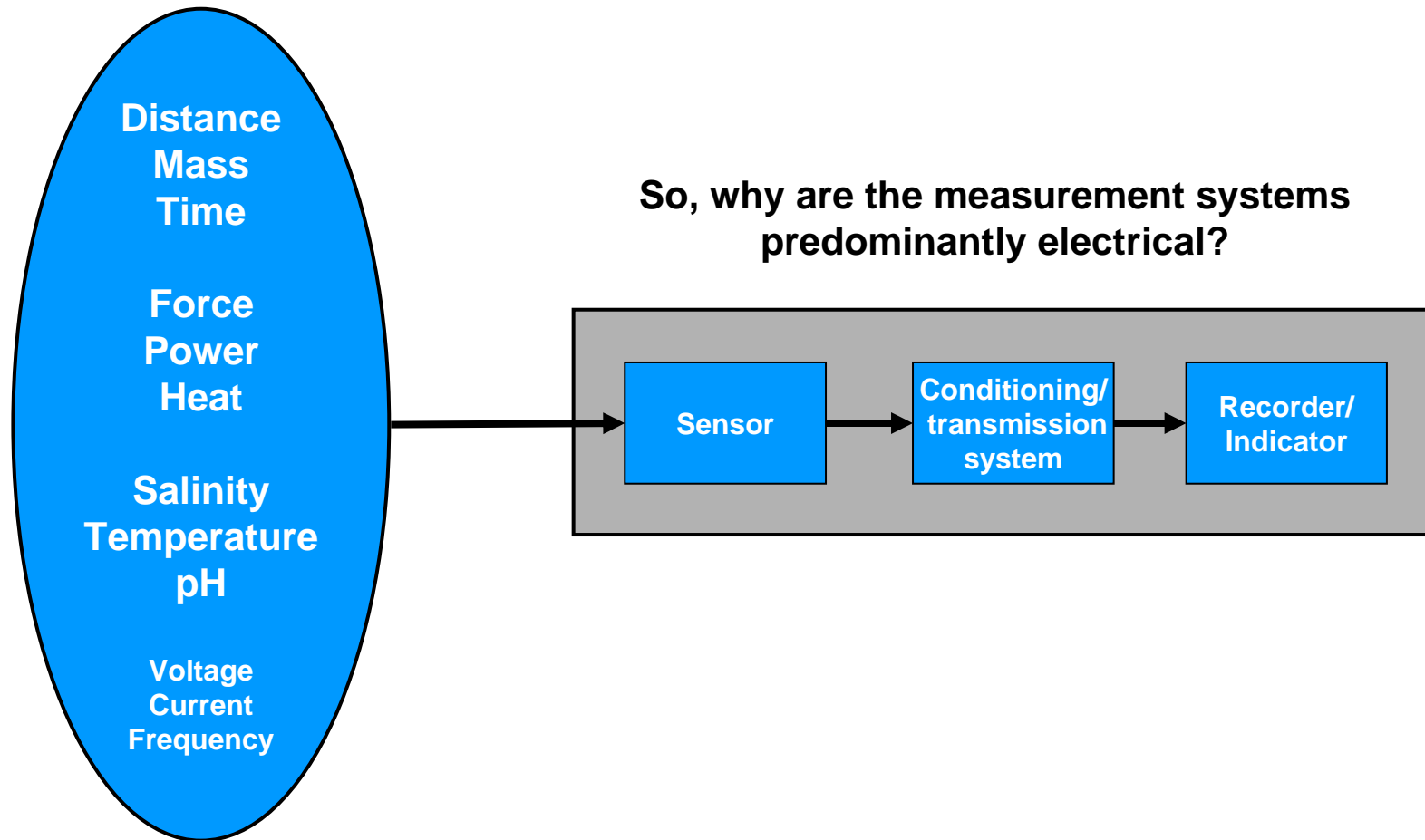

# Electrical Signals In a Physical World

- Most parameters we want to sense and record have physical values

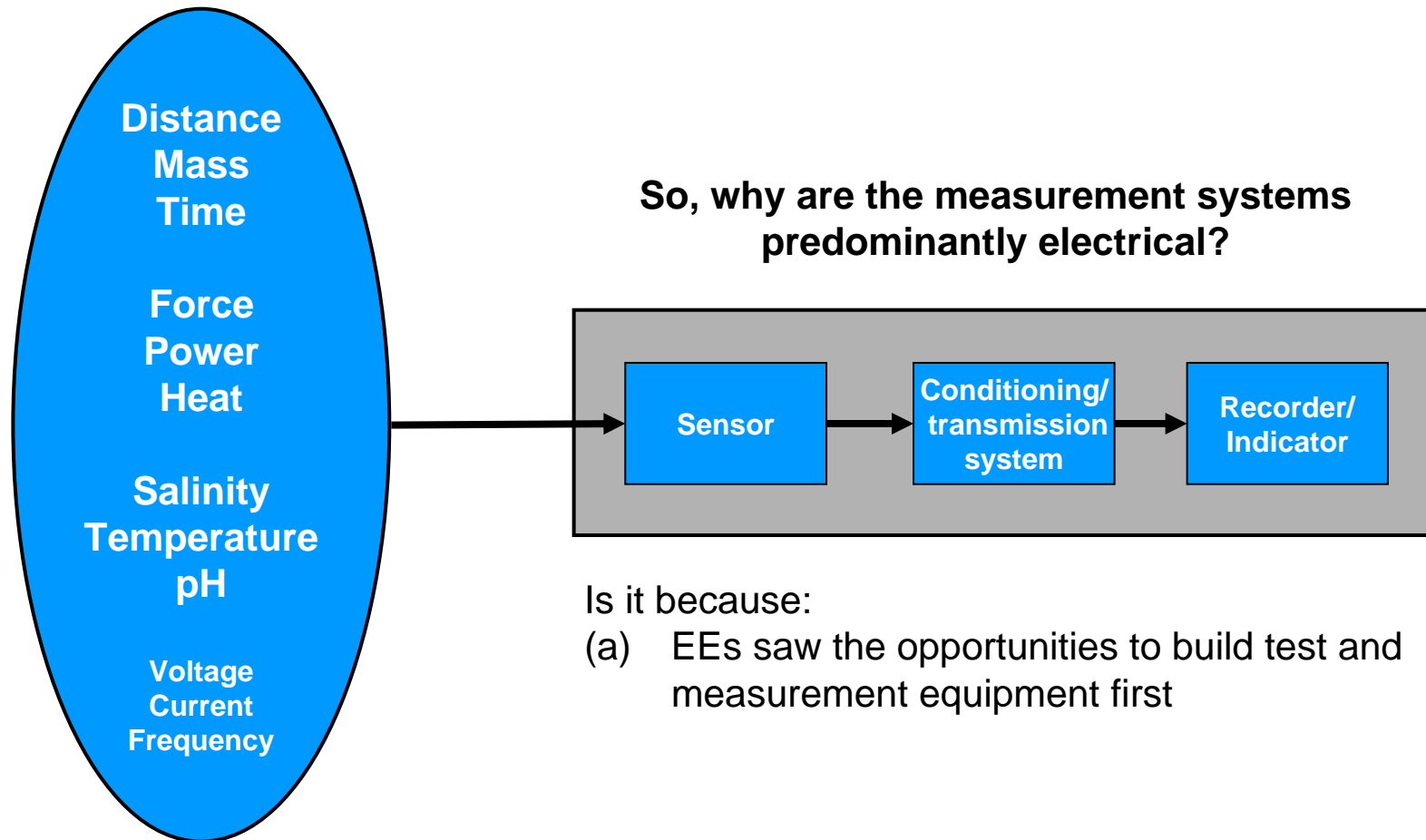

Is it because:

- (a) EEs saw the opportunities to build test and measurement equipment first

# Electrical Signals In a Physical World

- Most parameters we want to sense and record have physical values

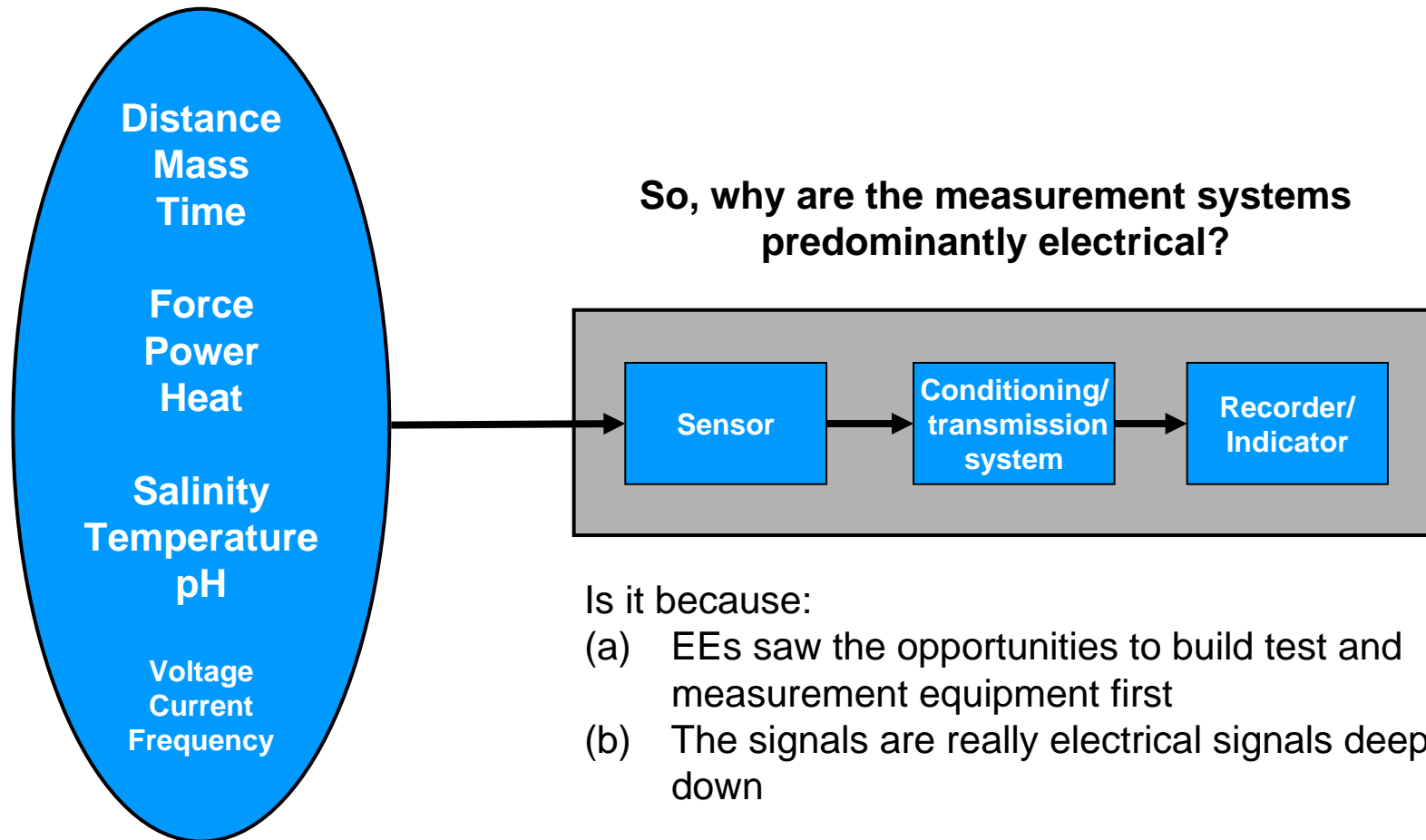

# Electrical Signals In a Physical World

- Most parameters we want to sense and record have physical values

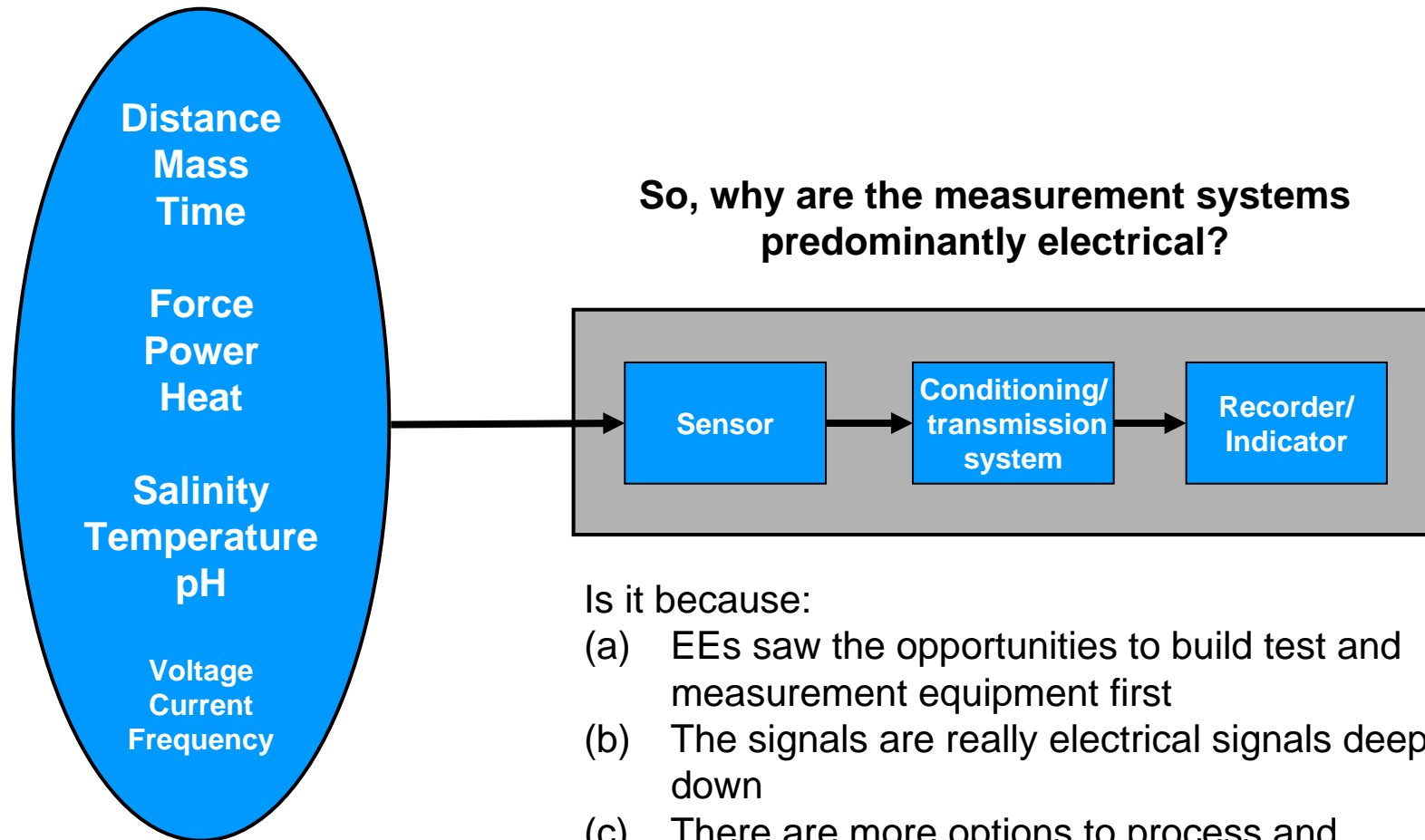

Is it because:

- (a) EEs saw the opportunities to build test and measurement equipment first
- (b) The signals are really electrical signals deep down
- (c) There are more options to process and transmit signals in electrical form

# Electrical Signals In a Physical World

- Most parameters we want to sense and record have physical values

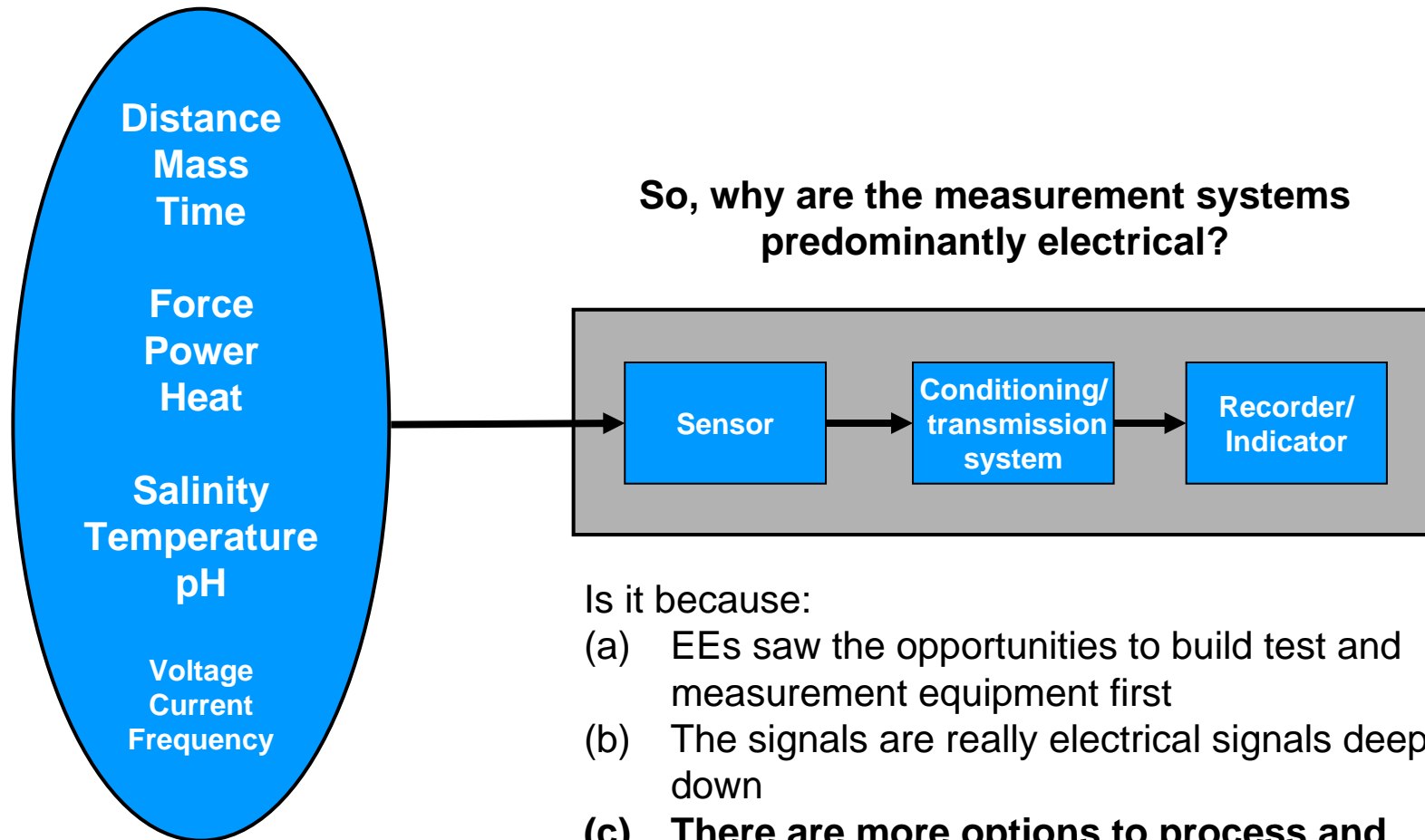

Is it because:

- (a) EEs saw the opportunities to build test and measurement equipment first
- (b) The signals are really electrical signals deep down
- (c) There are more options to process and transmit signals in electrical form**

# Signal Conditioning And Transformation

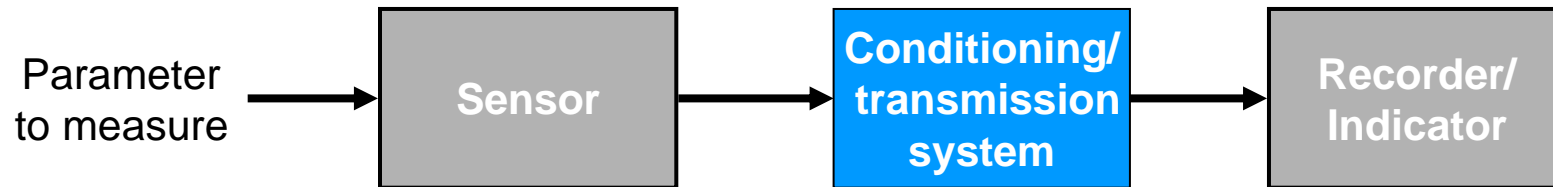

# Signal Conditioning And Transformation

- Amplification

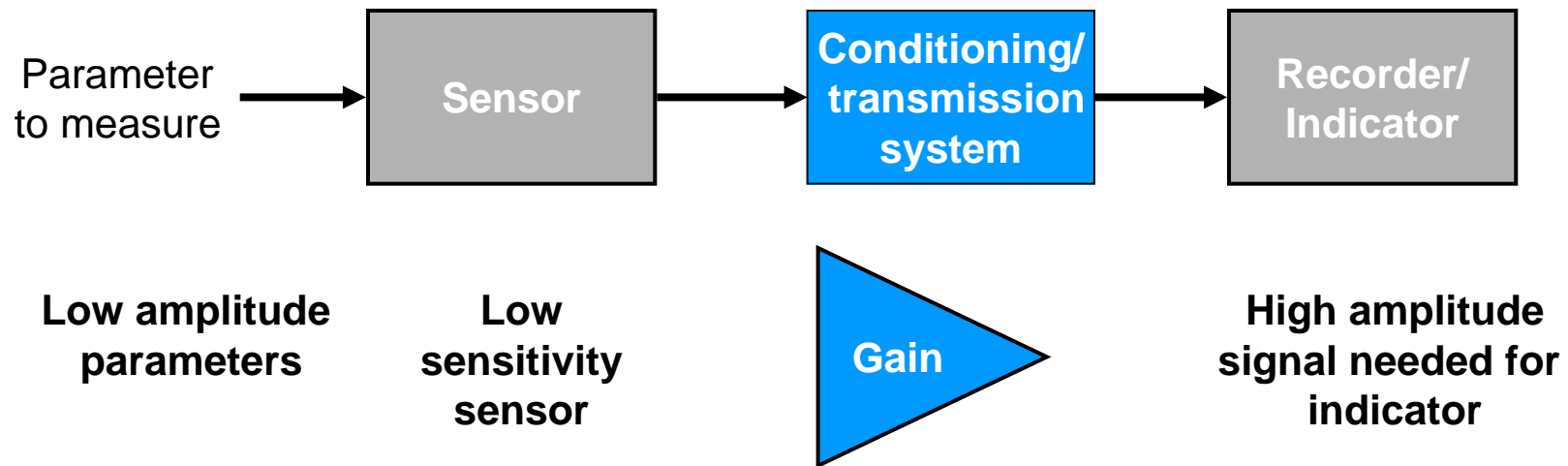

# Signal Conditioning And Transformation

- Amplification

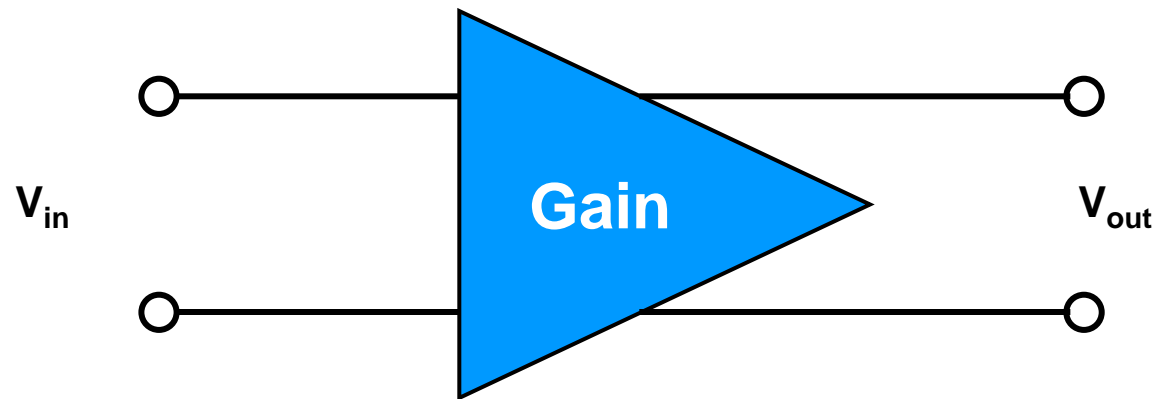

$$G = \frac{V_{out}}{V_{in}}$$

# Signal Conditioning And Transformation

- Amplification

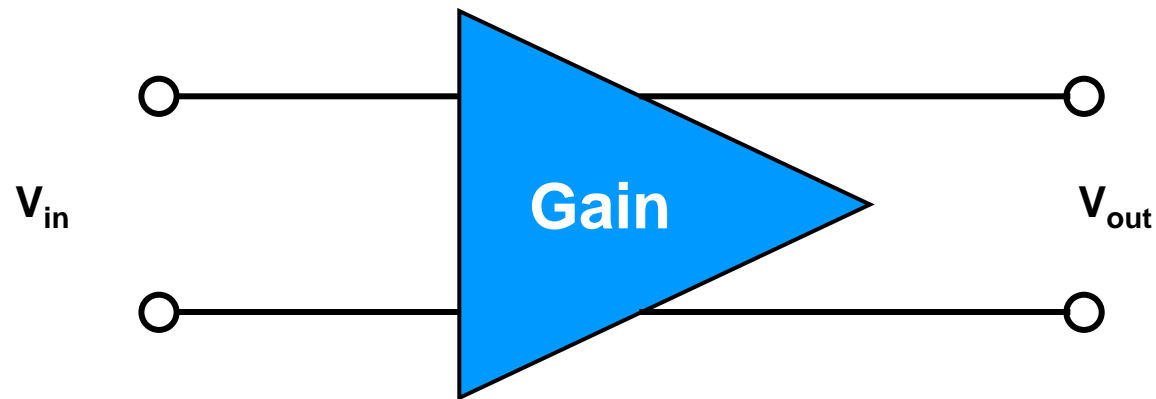

$$G_{dB} = 20 \cdot \log_{10} \left( \frac{V_{out}}{V_{in}} \right)$$

# Signal Conditioning And Transformation

- Amplification

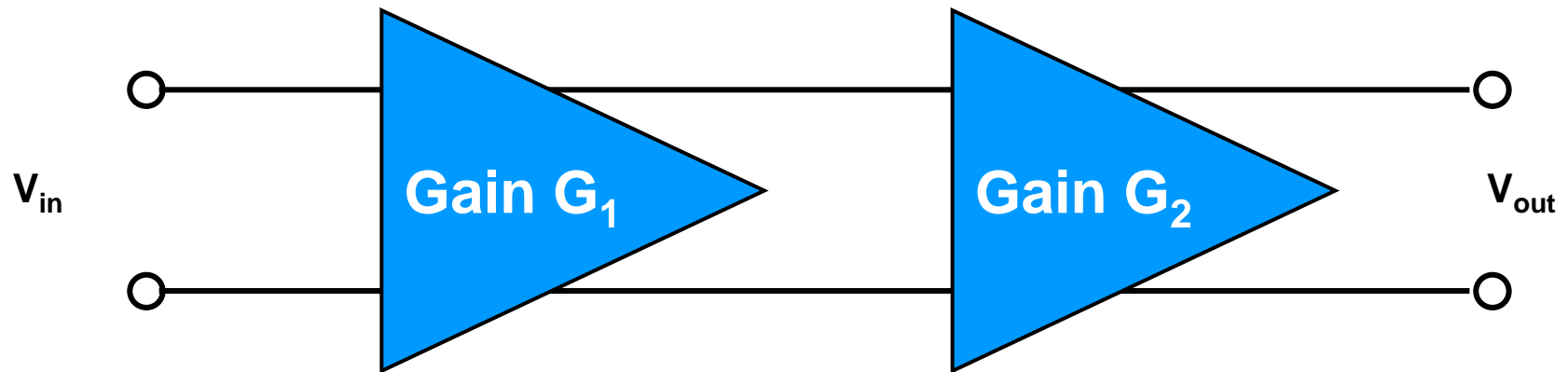

$$G_{overall} = G_1 \cdot G_2$$

$$G_{overall_{dB}} = G_{1_{dB}} + G_{2_{dB}}$$

# Signal Conditioning And Transformation

- Amplification

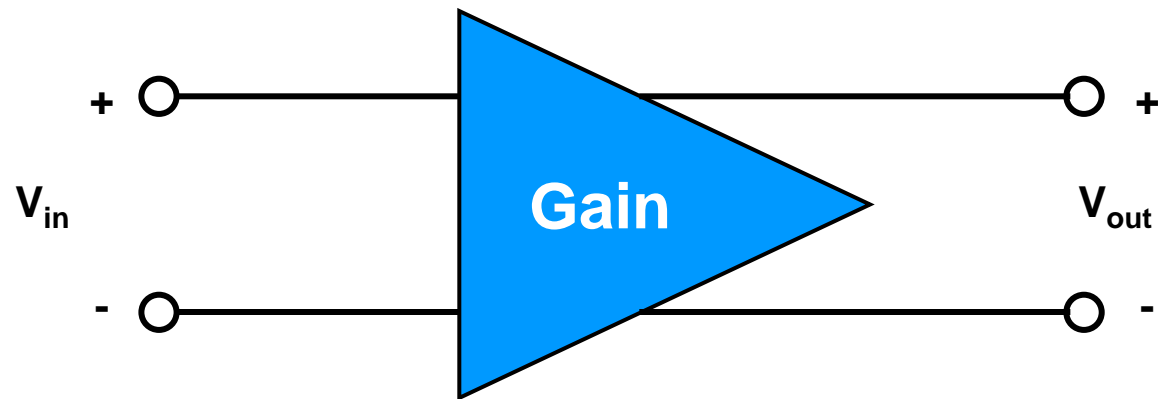

**Balanced inputs/outputs**

# Signal Conditioning And Transformation

- Amplification

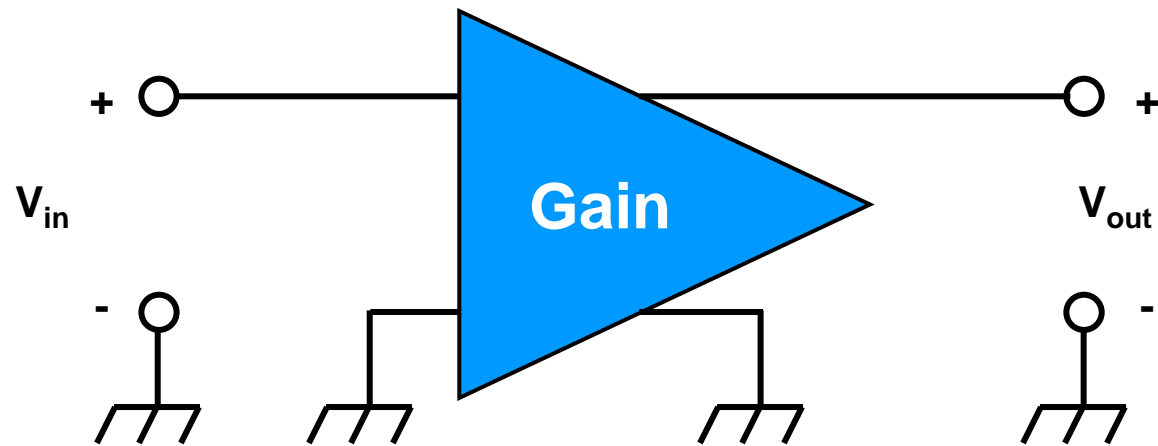

**Unbalanced (single-ended) inputs/outputs**

# Signal Conditioning And Transformation

- Attenuation

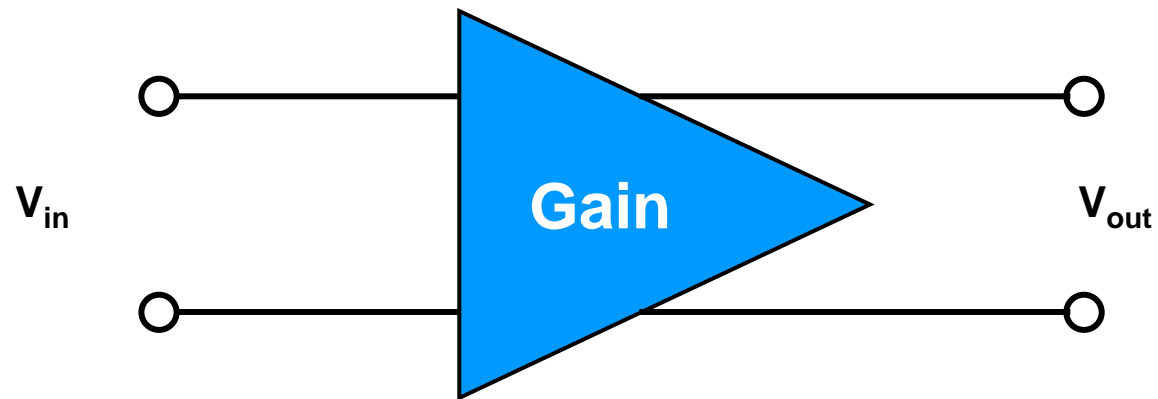

$$G < 1$$

$$G_{dB} < 0$$

# Signal Conditioning And Transformation

- Amplifier characteristics

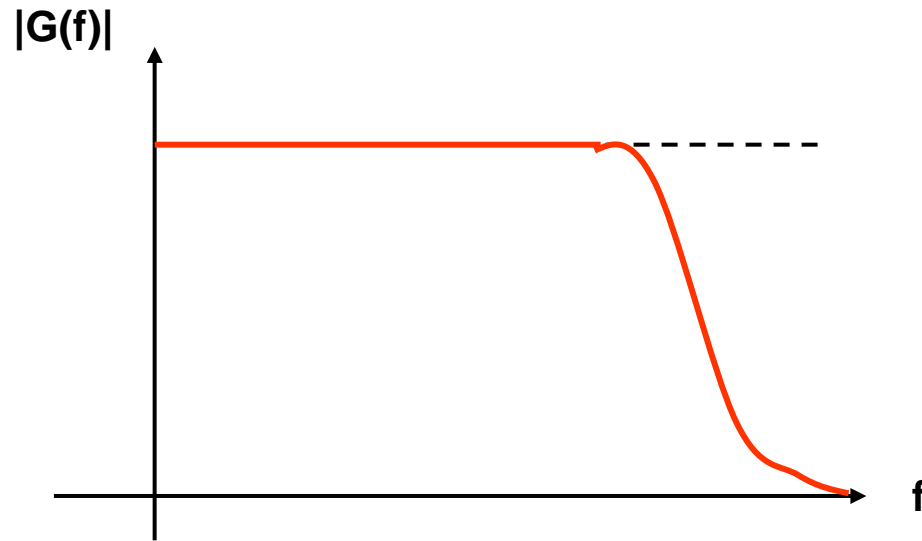

**Lowpass frequency response**

# Signal Conditioning And Transformation

- Amplifier characteristics

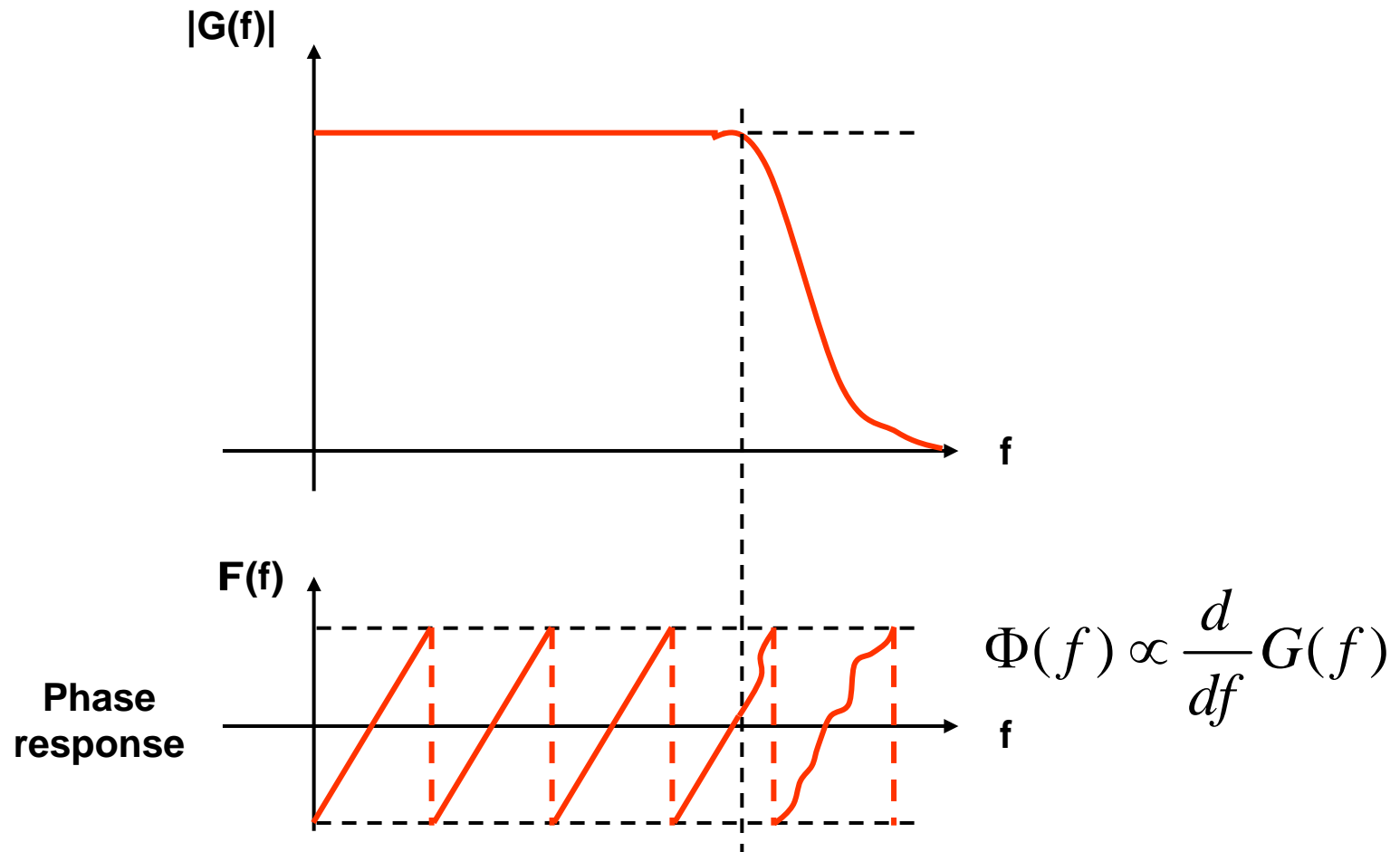

# Signal Conditioning And Transformation

- Amplifier characteristics

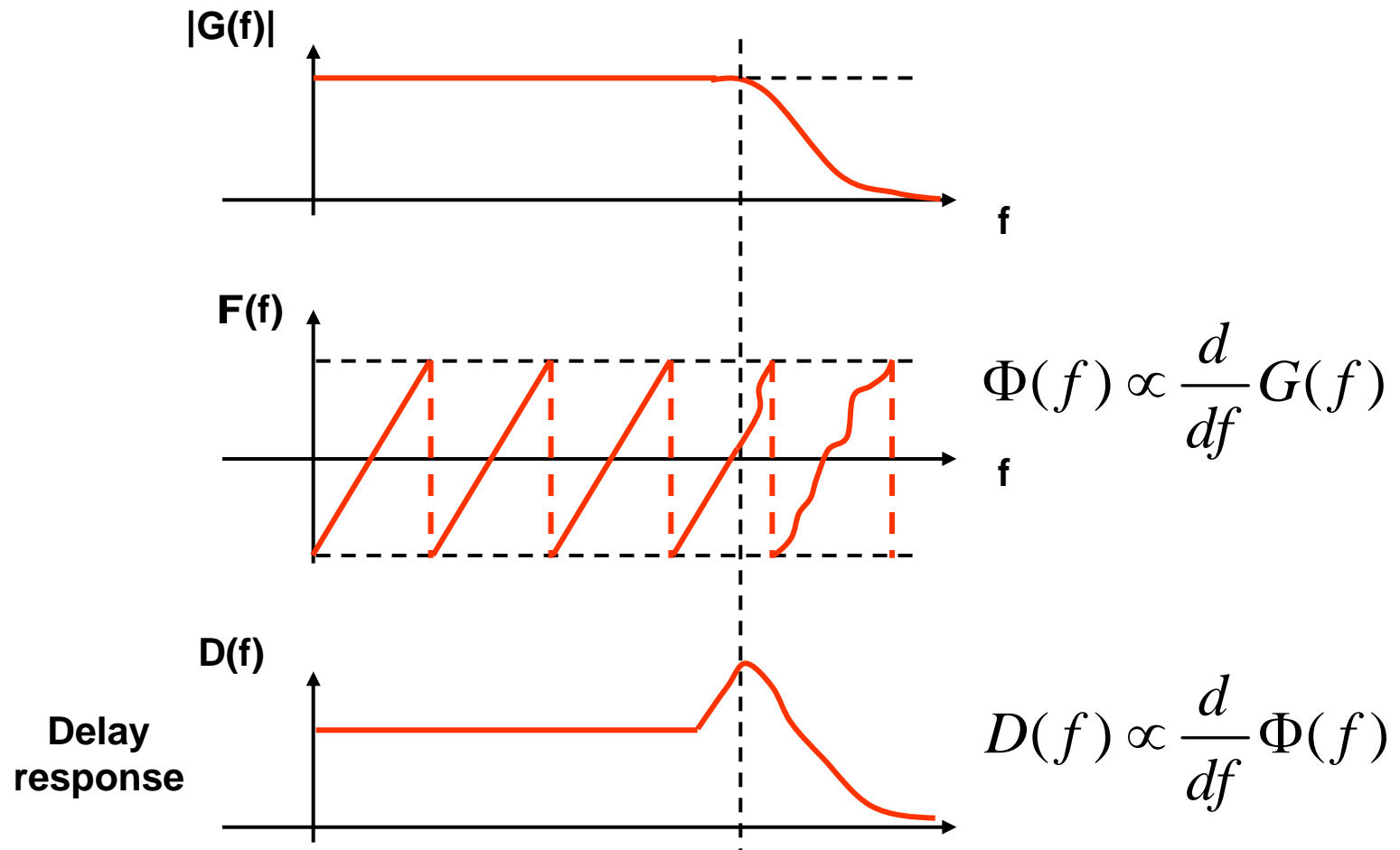

# Effect Of Phase-Shift Variation

- Sinusoidal signals:

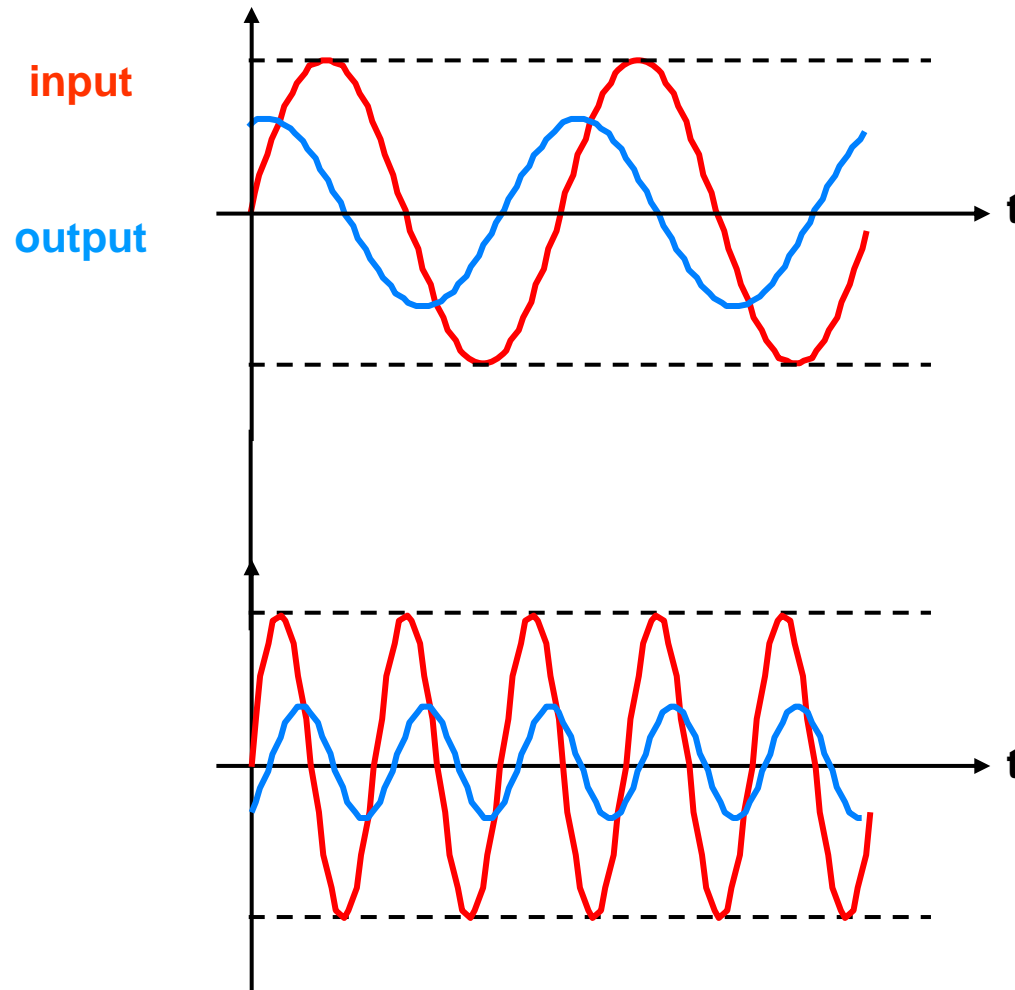

# Effect Of Phase-Shift Variation

- Non-sinusoidal signals:

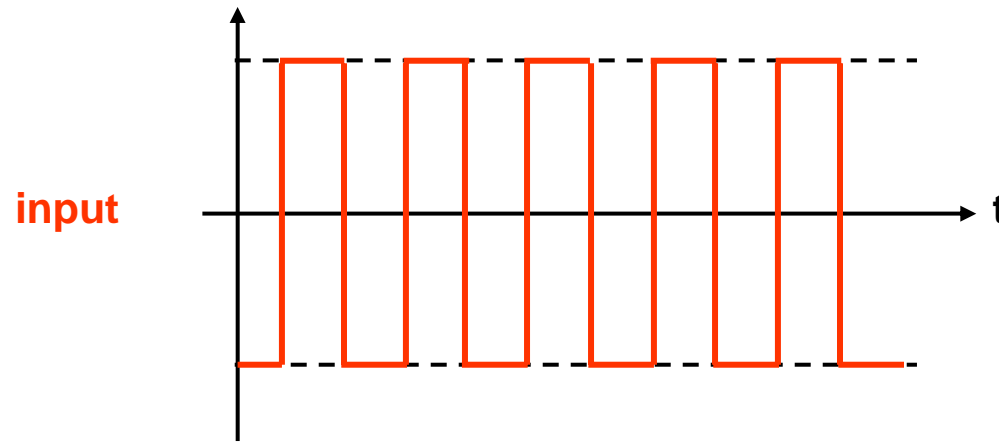

$$\sum_{i=1}^{\infty} \frac{\sin((2 \cdot i + 1) \cdot 2\pi f)}{2 \cdot i + 1}$$

# Effect Of Phase-Shift Variation

- Non-sinusoidal signals:

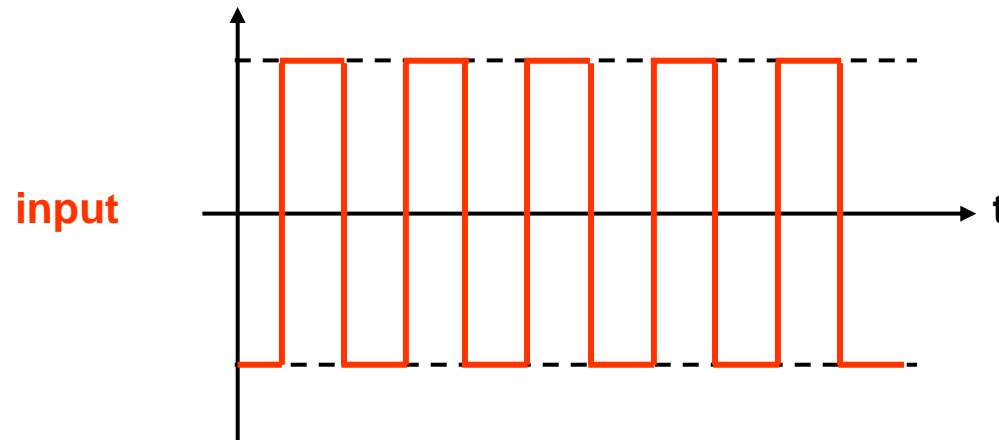

$$\sum_{i=1}^{\infty} \frac{\sin((2 \cdot i + 1) \cdot 2\pi f)}{2 \cdot i + 1}$$

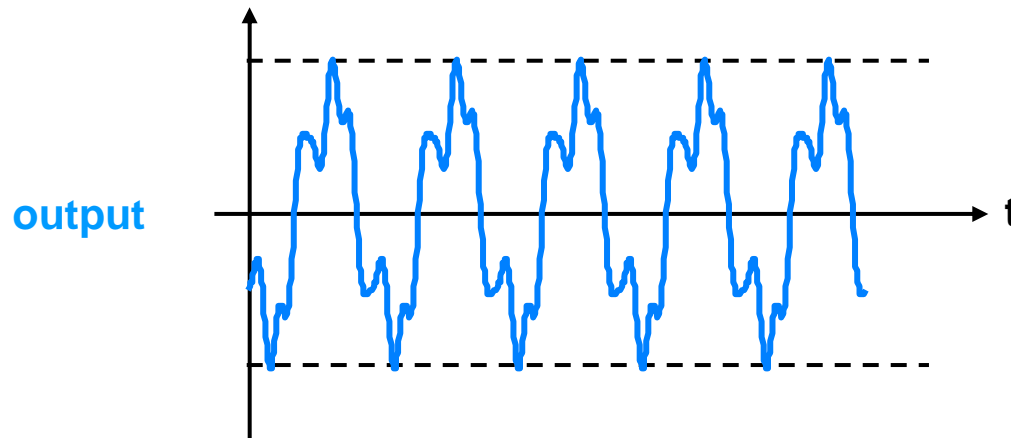

# Signal Conditioning And Transformation

- Other amplifier impairments – Common  
Mode Rejection Ratio

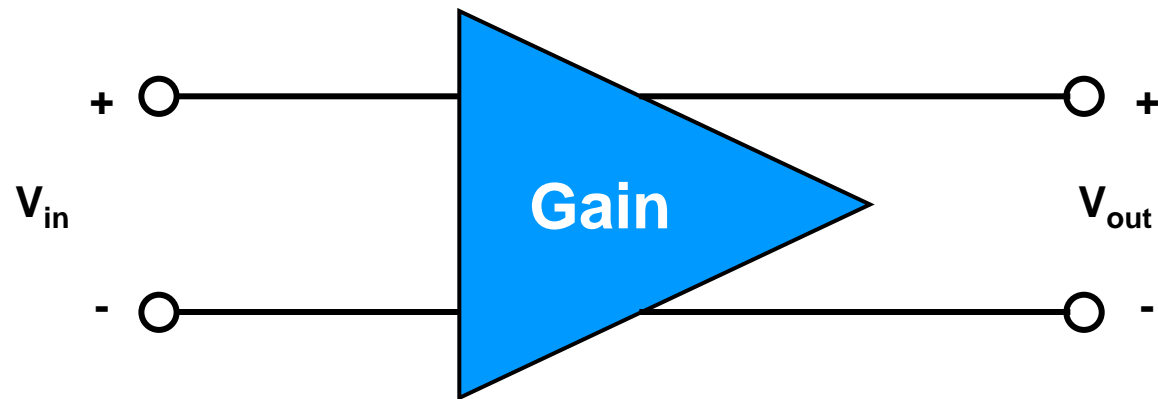

**Ideally:**

$$V_{out} = G \cdot (V_{in}^+ - V_{in}^-)$$

# Signal Conditioning And Transformation

- Other amplifier impairments – Common Mode Rejection Ratio

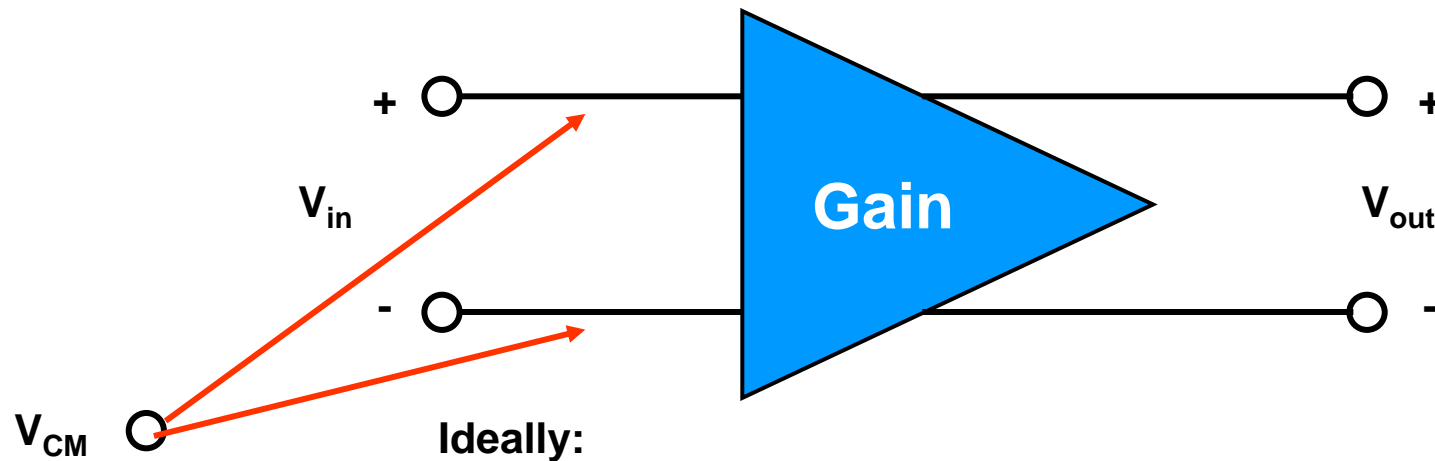

**Ideally:**

$$V_{out} = G \cdot (V_{in}^+ - V_{in}^-)$$

**Practically:**

$$V_{out} = G_{diff} \cdot (V_{in}^+ - V_{in}^-) + G_{CM} \cdot (V_{CM})$$

# Signal Conditioning And Transformation

- Other amplifier impairments – Common Mode Rejection Ratio

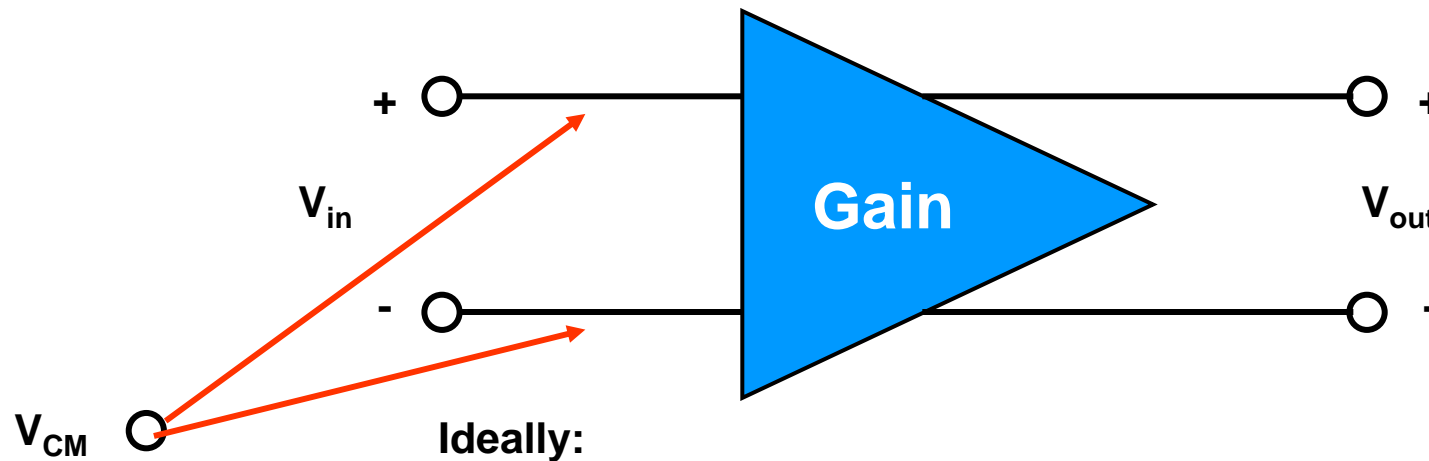

Ideally:

$$V_{out} = G \cdot (V_{in}^+ - V_{in}^-)$$

Practically:

$$V_{out} = G_{diff} \cdot (V_{in}^+ - V_{in}^-) + G_{CM} \cdot (V_{CM})$$

$$CMRR = 20 \cdot \log \left( \frac{G_{diff}}{G_{CM}} \right)$$

# Signal Conditioning And Transformation

- Amplifier impedance

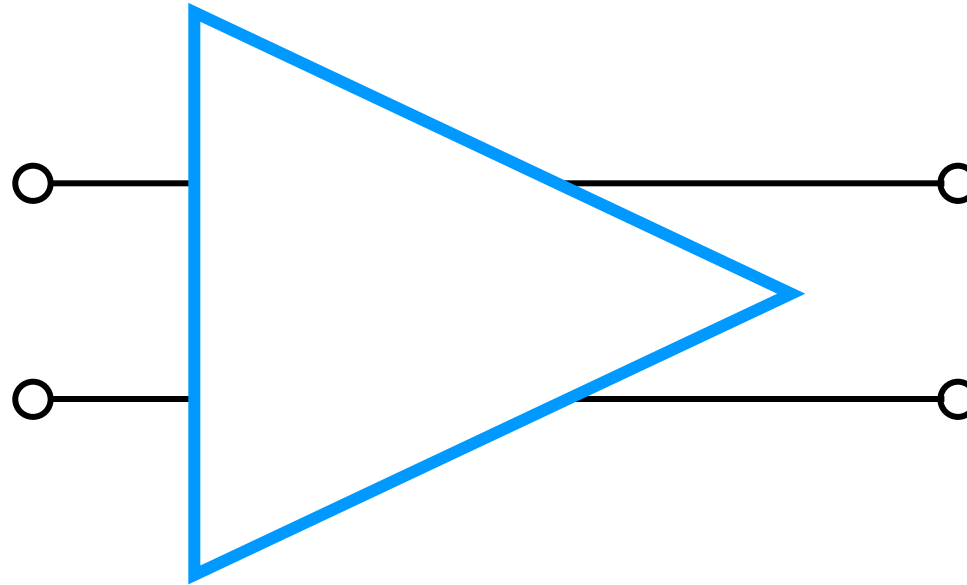

# Signal Conditioning And Transformation

- Amplifier impedance

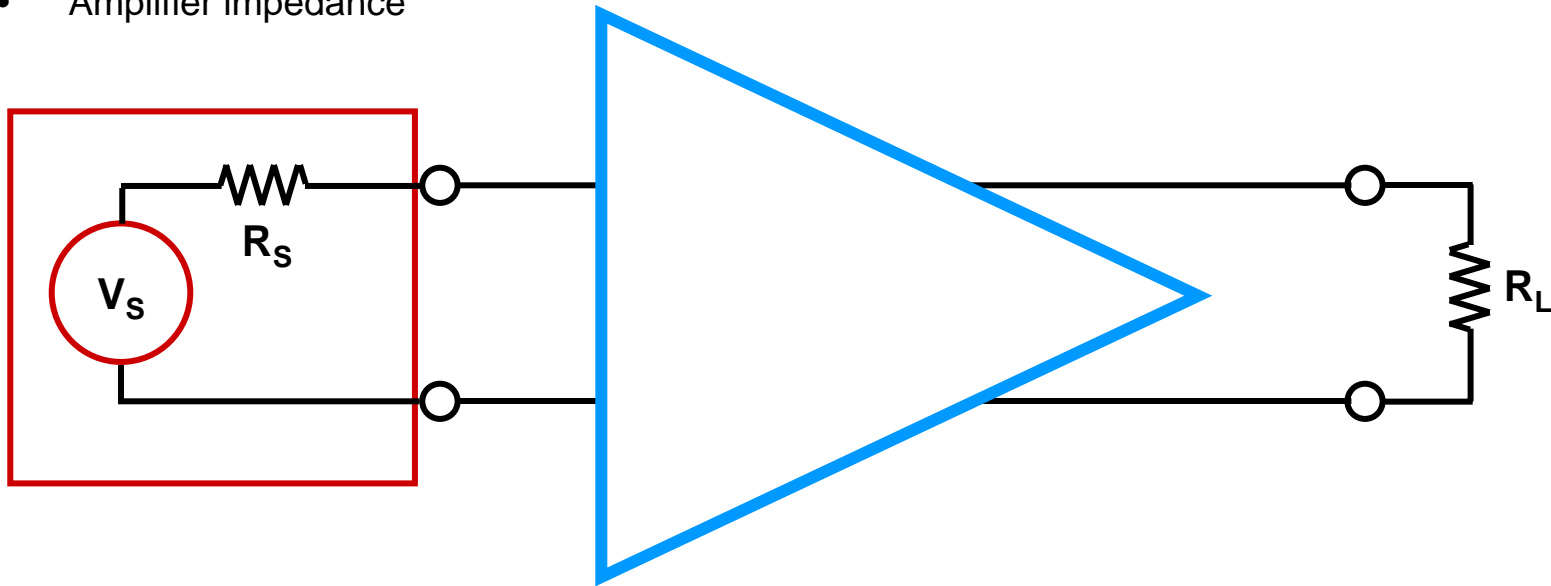

# Signal Conditioning And Transformation

- Amplifier impedance

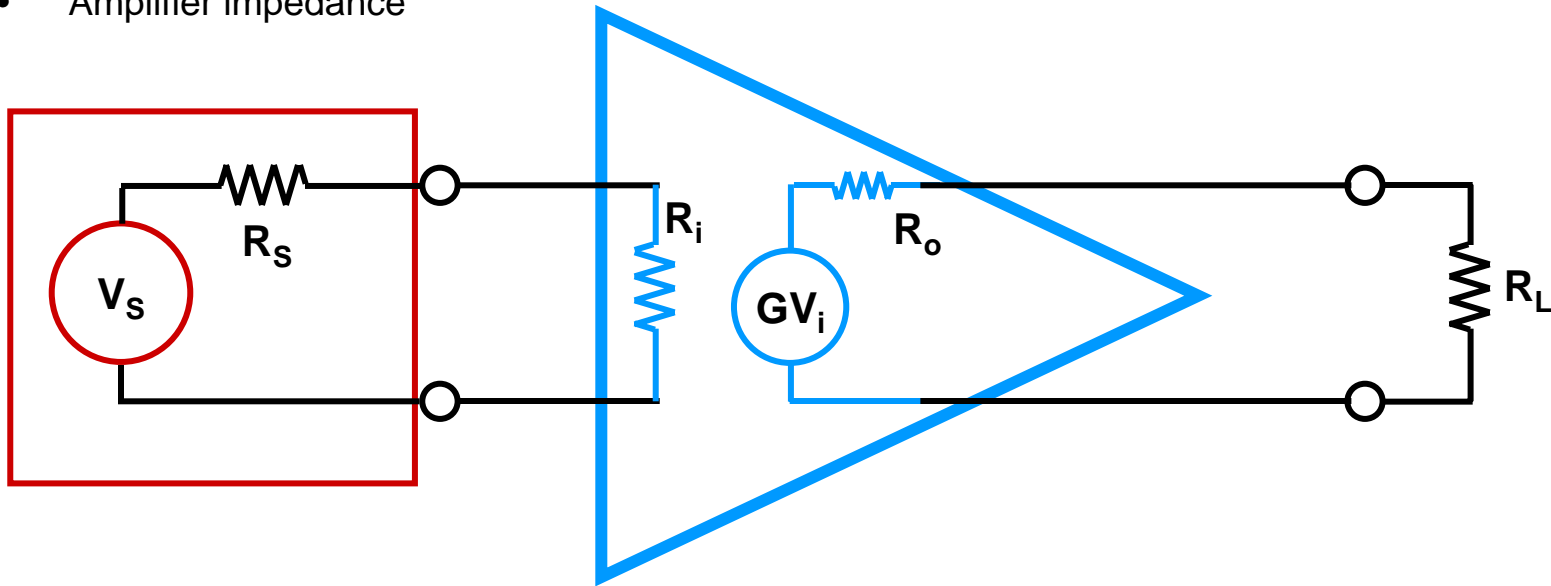

**For greatest voltage gain, best frequency response:**

$$R_i \rightarrow \infty$$

$$R_o \rightarrow 0$$

# Next topics

- Signal conditioning, transformation
  - Amplifiers
    - DC drift
    - Operational Amplifiers
  - Filtering
    - Filter families
  - Integration, differentiation, comparison
- Indicators and recording devices
  - Voltage
  - Waveforms
  - Frequency
  - Spectrum
- Transmission
  - Signal level considerations
  - Interference sources
  - Ground loops
  - Rationale for digital signal transmission