

Design IV

E232 Spring 07

Class 18

Bruce McNair
bmcnair@stevens.edu

Displacement Sensors

- Potentiometer

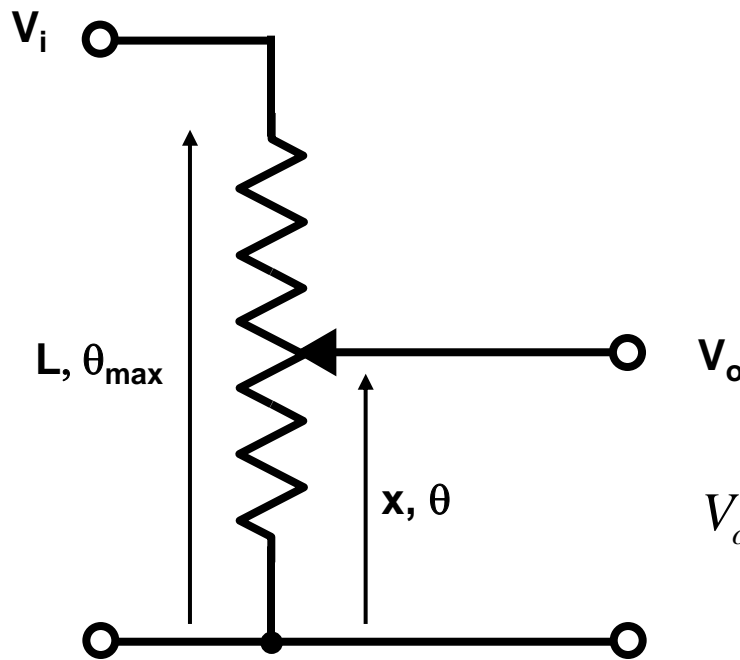

Issues:

- Noise
- Linearity
- Resolution
- Measurement range
- Lifetime
- Discrete steps

$$V_o = \frac{\theta}{\theta_{\max}} V_i$$

$$V_o = \frac{x}{L} V_i$$

Displacement Sensors

- Differential Transformer

Issues:

- **Measurement range**

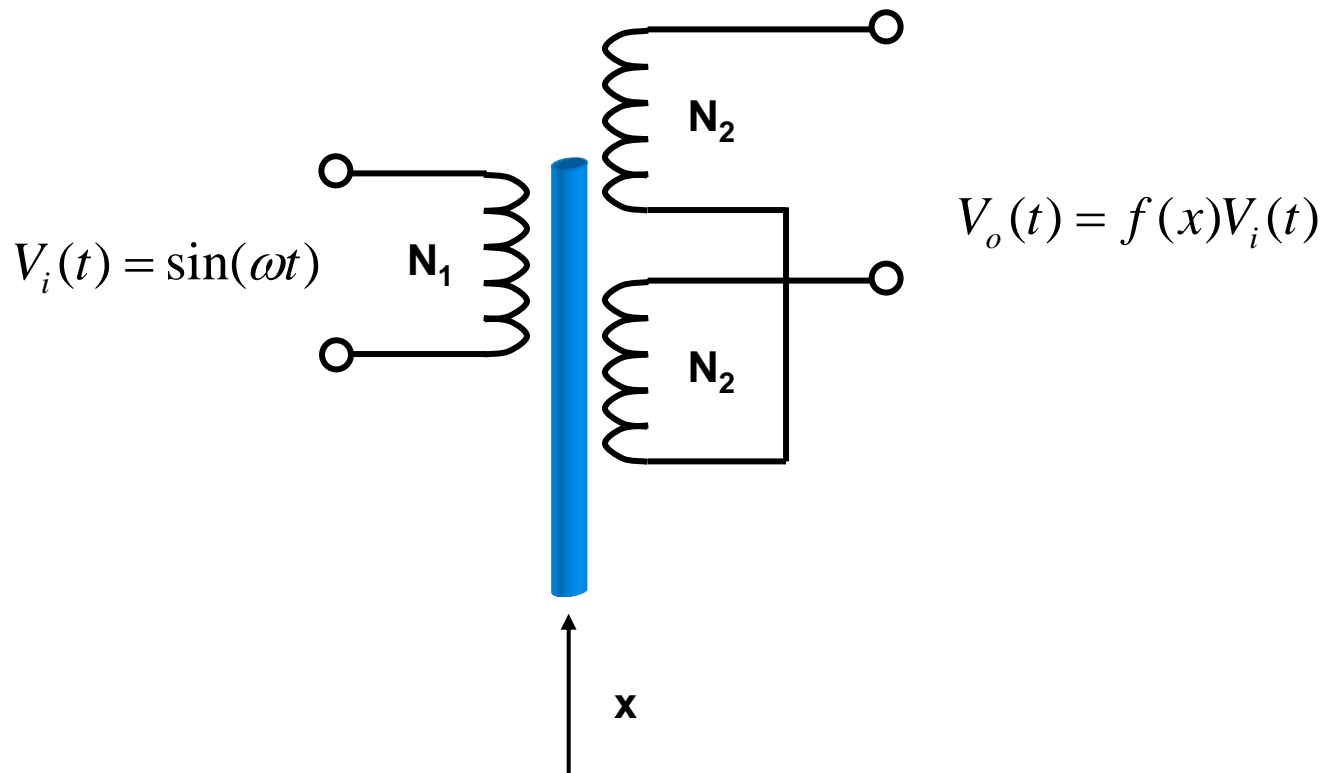

Rotation/Displacement Sensors

- Rotary capacitor

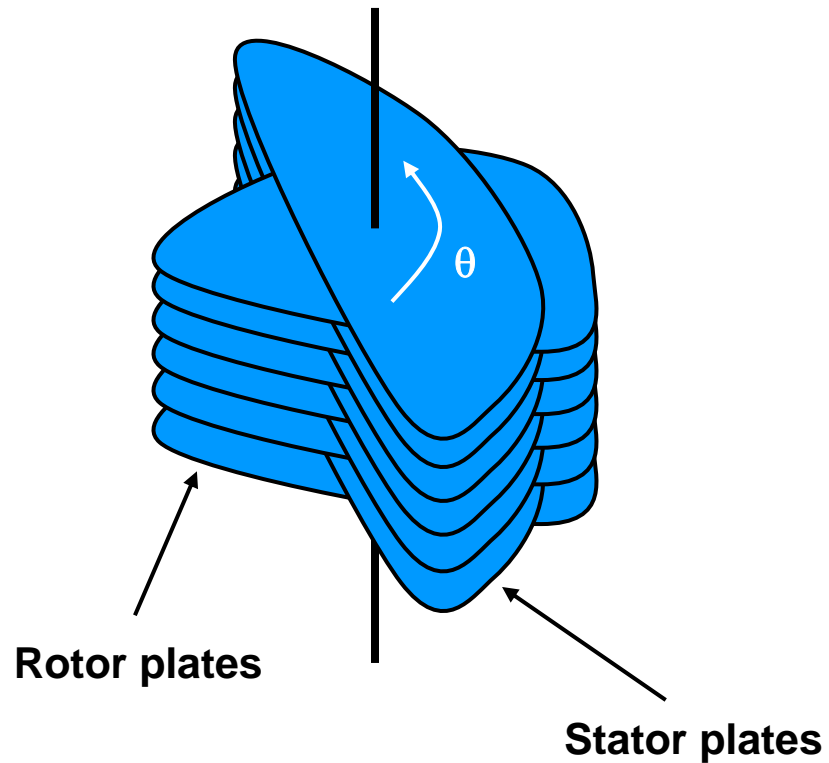

$$C = K \epsilon_0 \frac{A(\theta)}{d}$$

Issues:

- Measurement range
- Linearity

Rotation Sensors

- Digital angular encoder

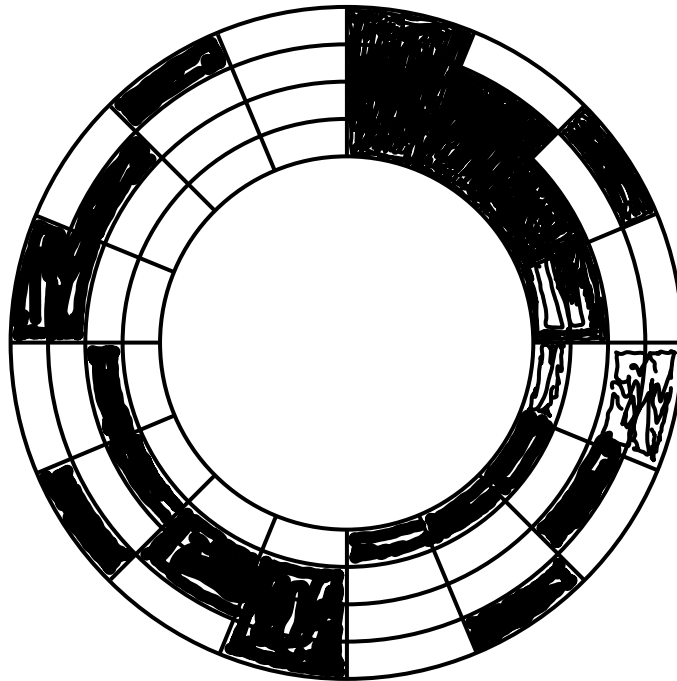

**Binary encoding of angle
e.g., 4-bit encoder**

0000
0001
0010
0011
0100
0101
0110
0111
1000
1001
1010
1011
1100
1101
1110
1111

Issues:

- Quantization

Today's topics

- Measurement sensors
 - Strain
 - Displacement
 - **Velocity**
 - Rotation
 - **Acceleration**
 - **Force**
 - **Torque**

Velocity Sensors

- A changing magnetic field induces a current in a coil of wire proportional to the rate of change of the magnetic field and the number of windings

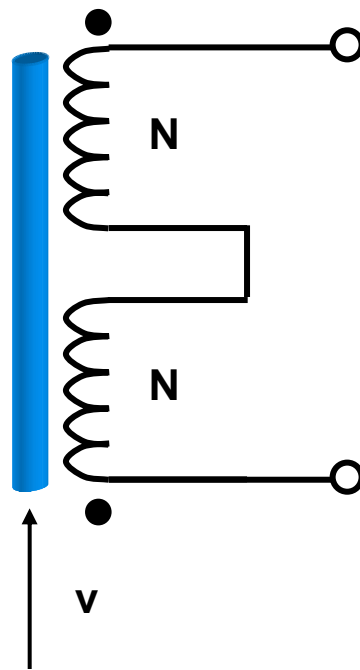

$$V_o(t) = f(v(t))$$

Velocity Sensors

- A changing magnetic field induces a current in a coil of wire proportional to the rate of change of the magnetic field and the number of windings

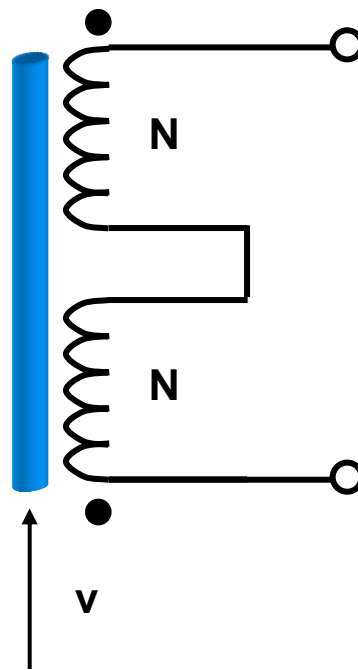

$$V_o(t) = f(v(t))$$

Issues:

- Effects of displacement, as well as velocity
- Linearity
- Measurement range

Velocity Sensors

- Doppler shift

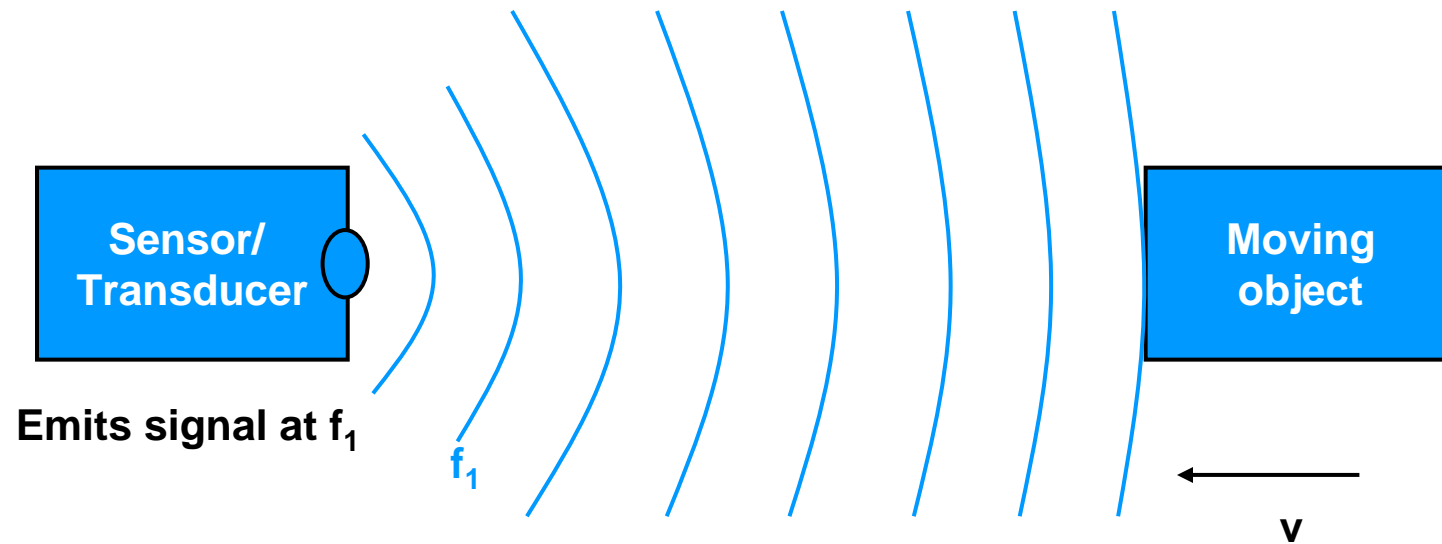

Velocity Sensors

- Doppler shift

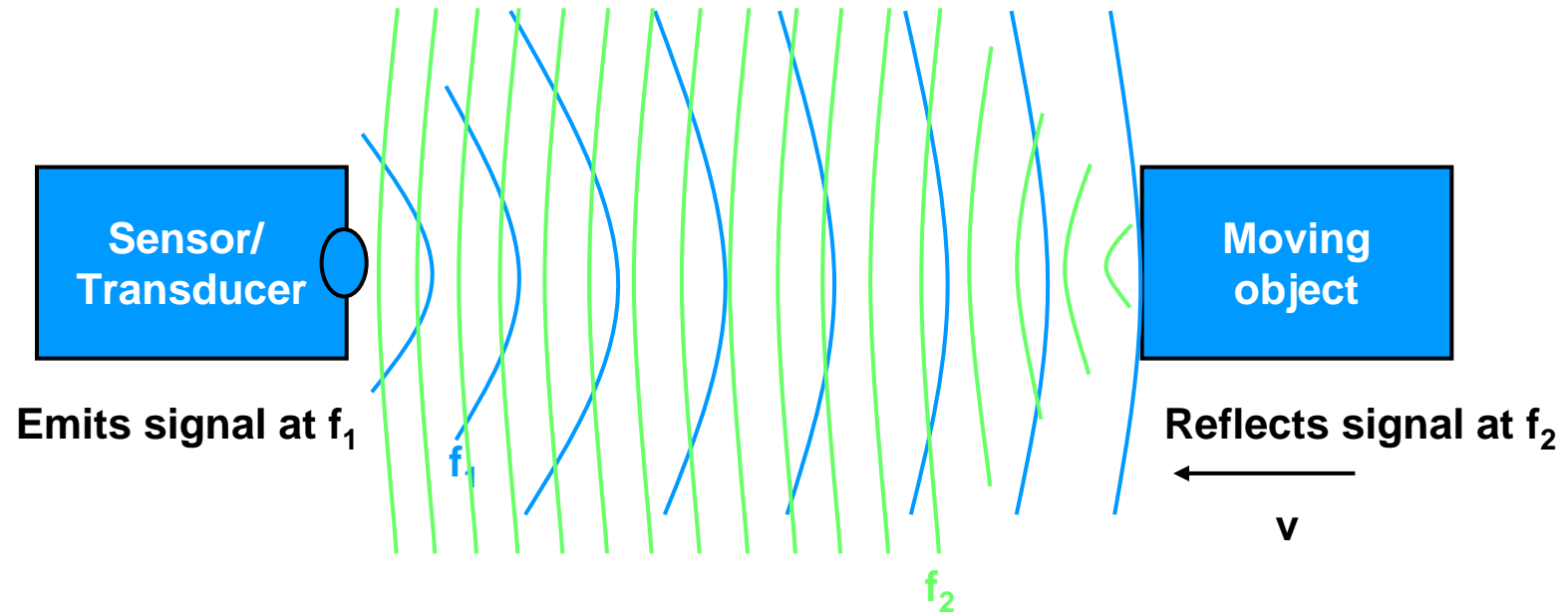

$$|f_1 - f_2| = \frac{2v}{\lambda}$$

Where v is the component of velocity in line with sensor

v_0 for sound is ~1 ft/millisecond
 v_0 for light/RF is ~1 ft/nanosecond

$$f \lambda = v_0$$

Where v_0 is velocity of wave in media

Displacement Sensors

- Doppler shift

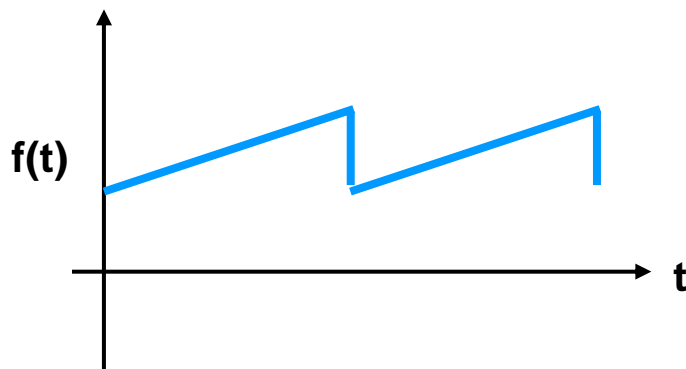
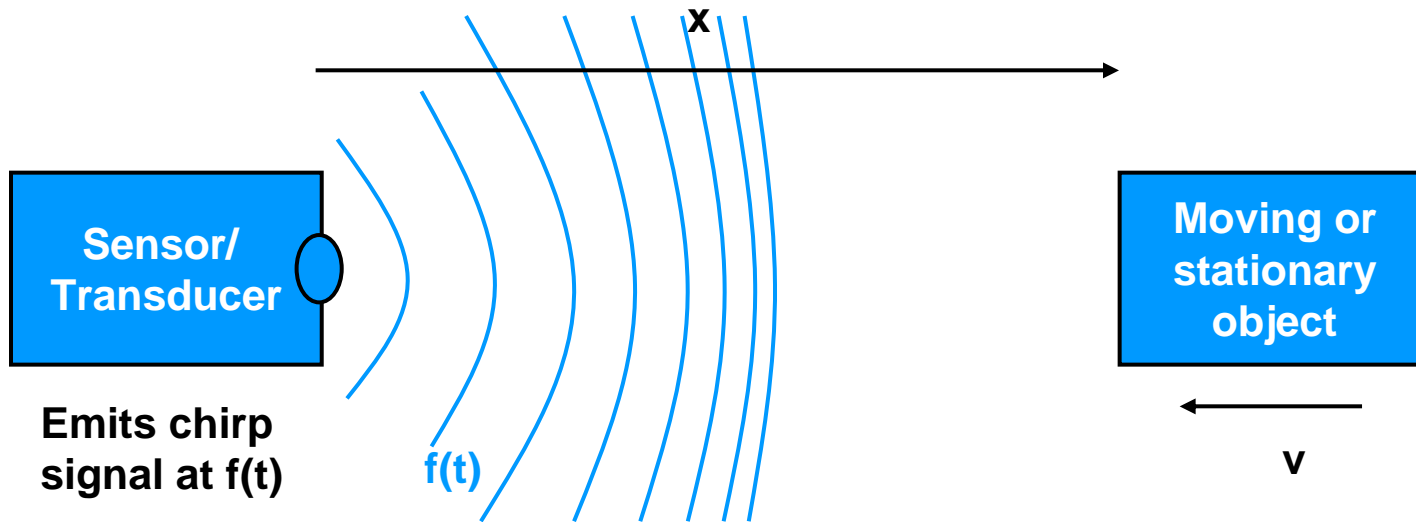

Velocity/Displacement Sensors

- Doppler shift

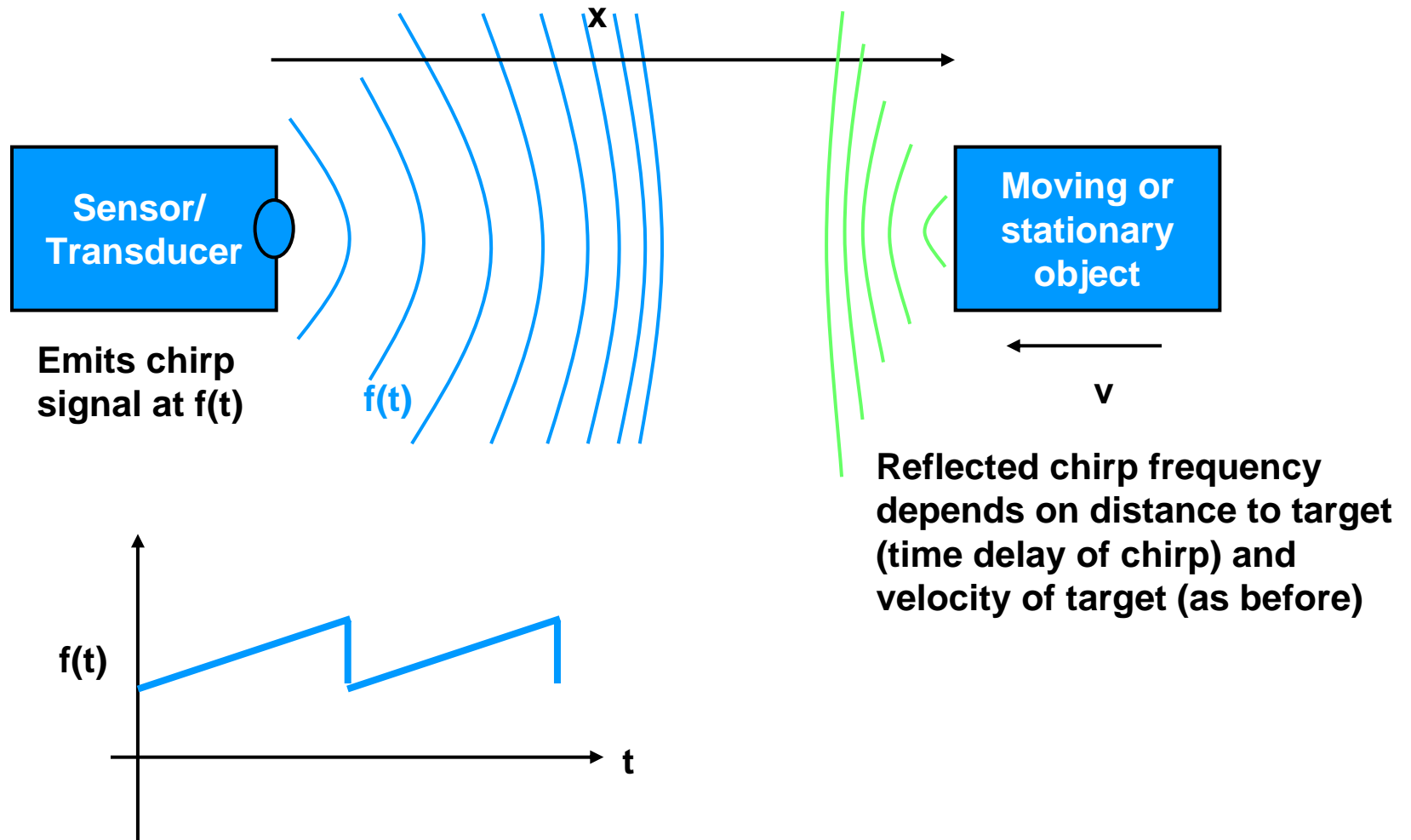

Velocity/Displacement Sensors

- Doppler shift

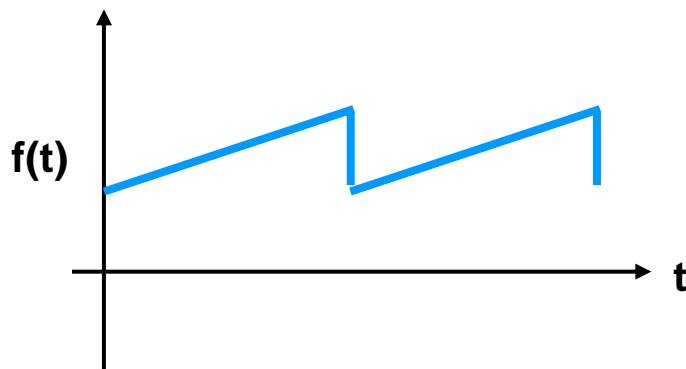
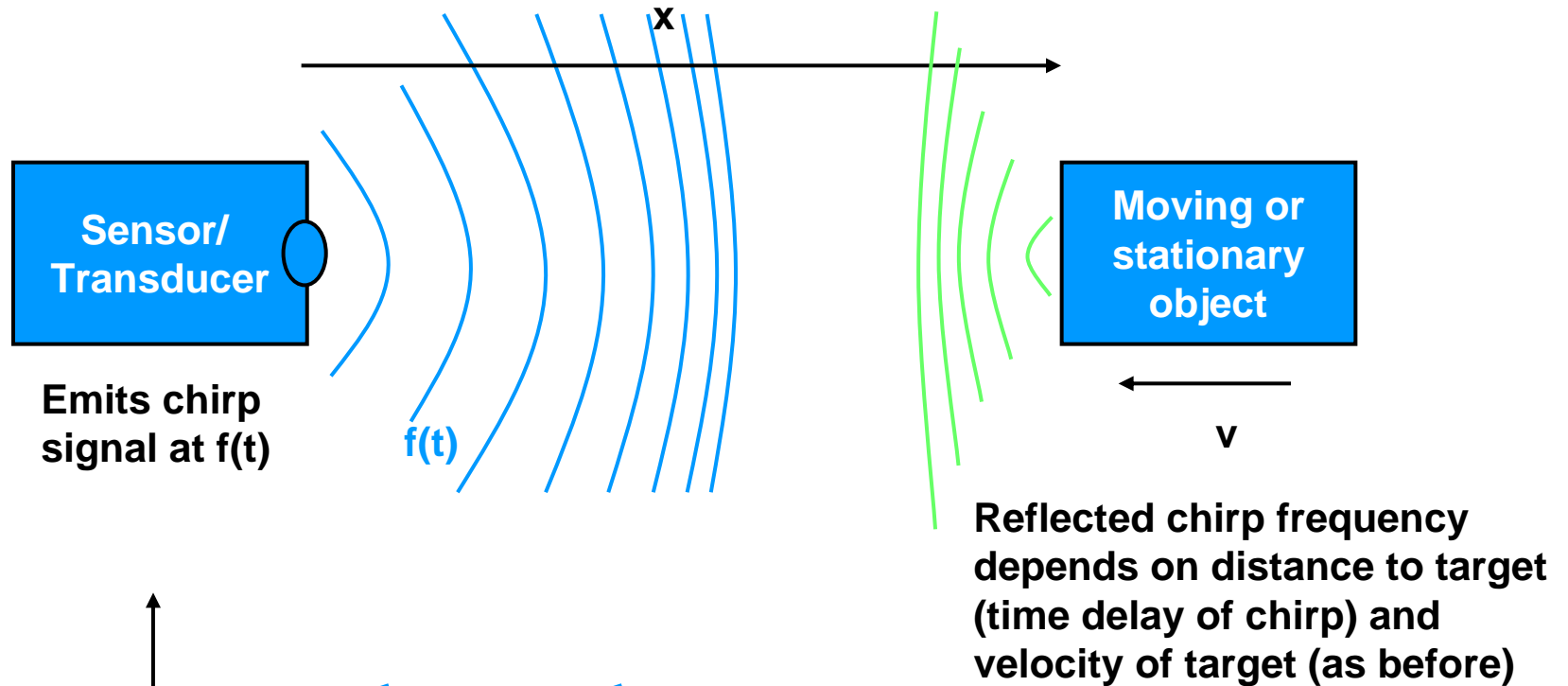

Applications:

- Bat's method of sensing prey
- Non-contact materials sensing
- Medical doppler ultrasound
- Weather doppler radar
- Geolocation/navigation

Acceleration Sensors

- Acceleration is a derivative of velocity, second derivative of displacement

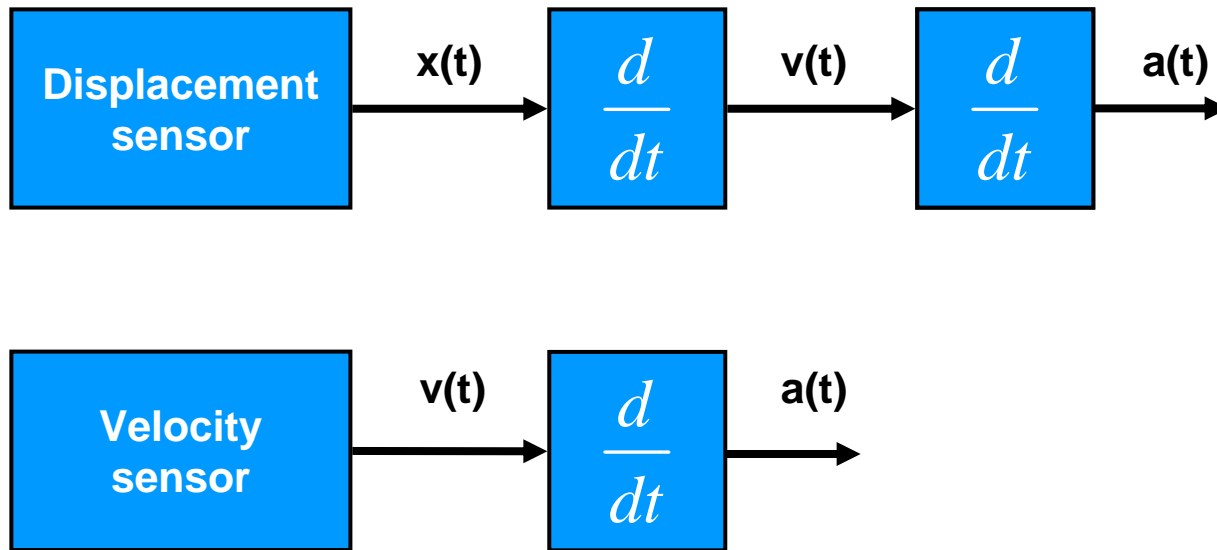

Acceleration Sensors

- Acceleration is a derivative of velocity, second derivative of displacement

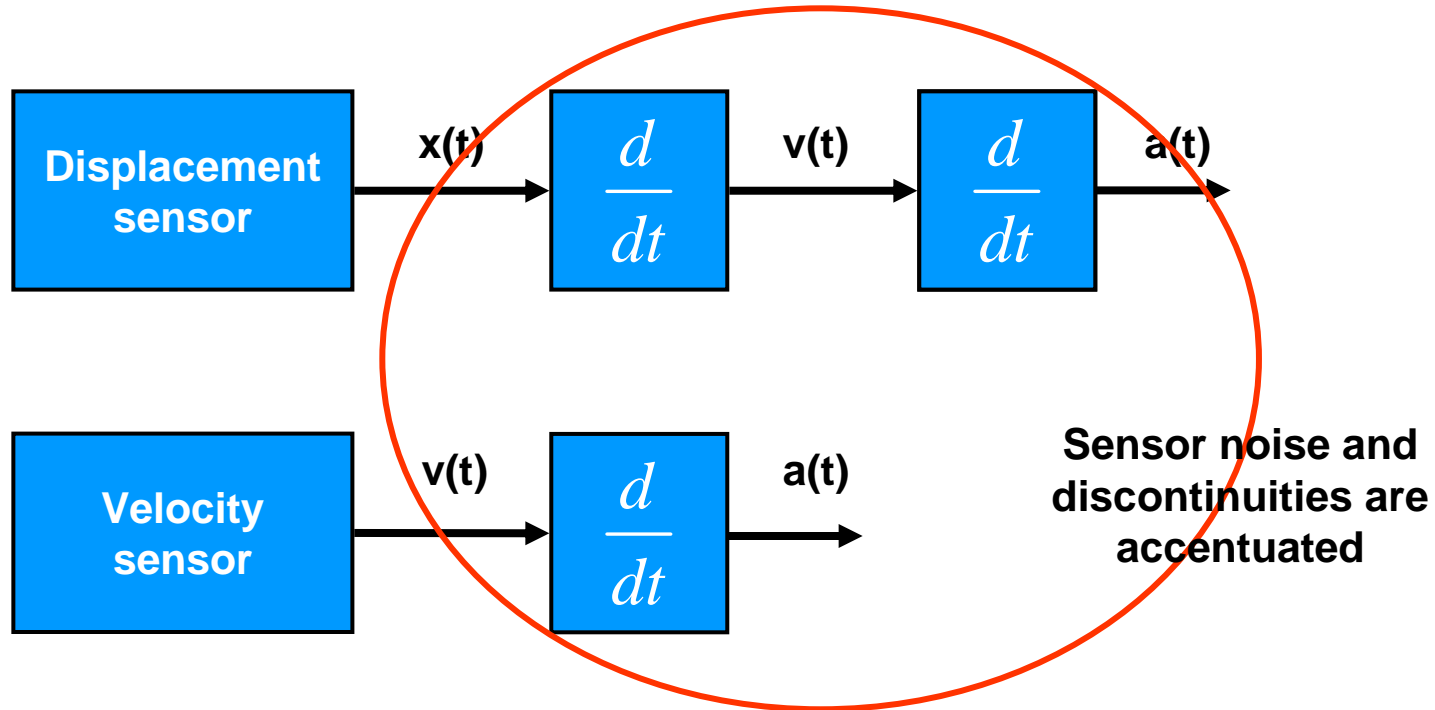

Acceleration Sensors

- Piezoelectric ($F=ma$) sensors

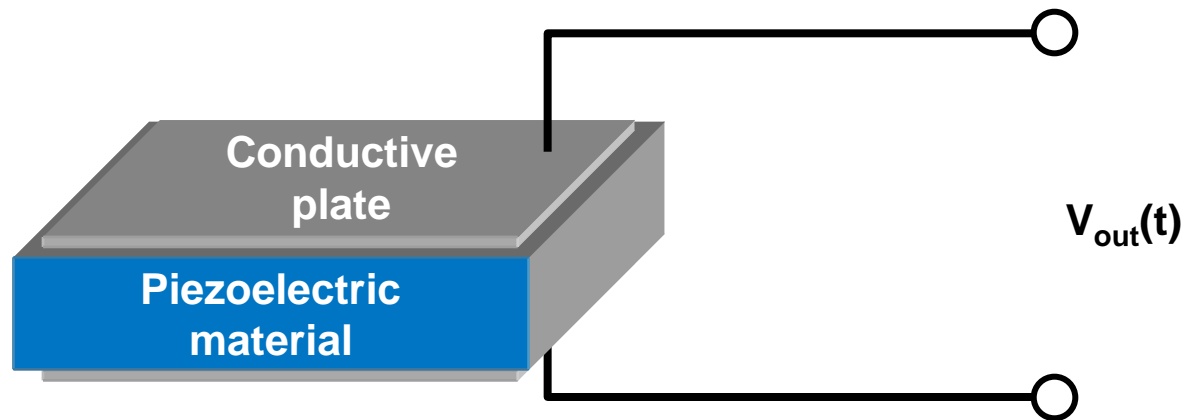

Acceleration Sensors

- Piezoelectric ($F=ma$) sensors

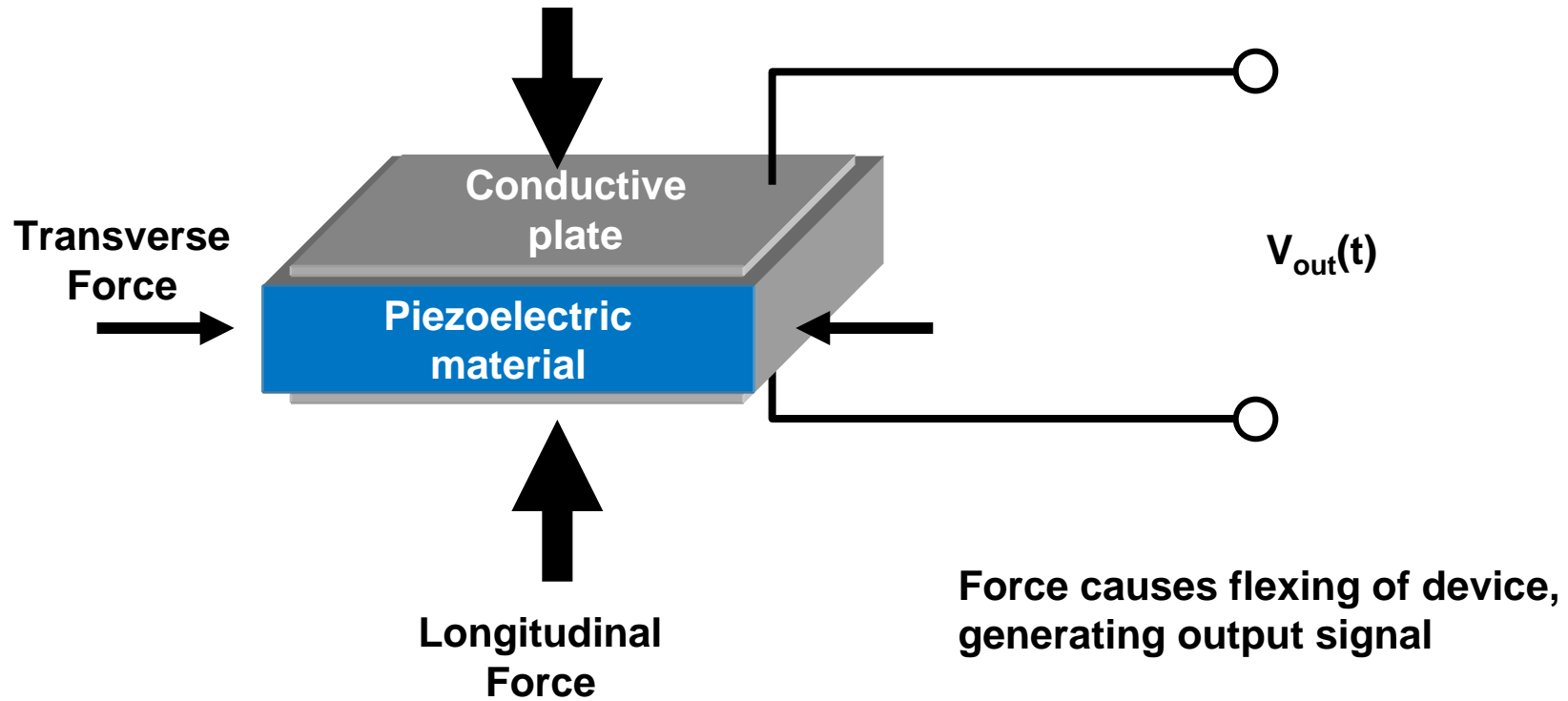

Acceleration Sensors

- Piezoelectric ($F=ma$) sensors

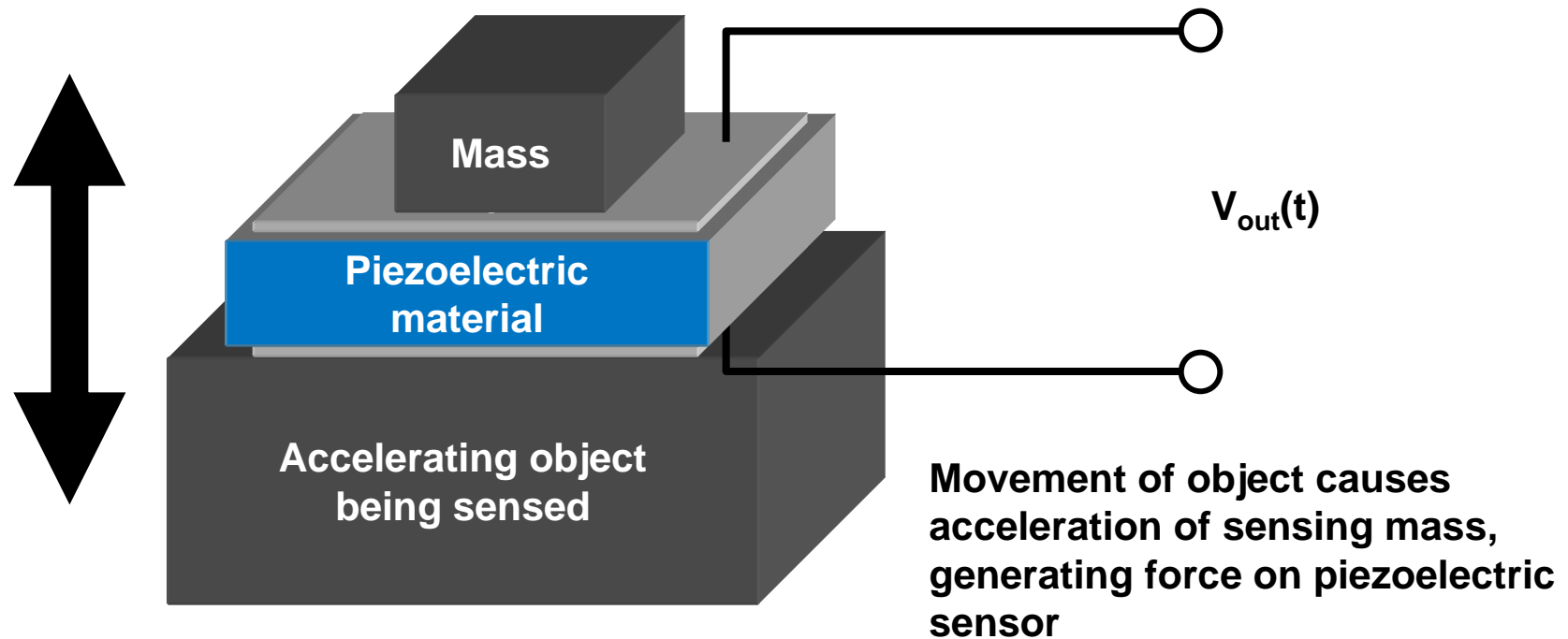

Acceleration Sensors

- Piezoelectric ($F=ma$) sensors

Other applications:

- Motion sensing game controllers
- Vehicle braking, stability sensors
- Hard disk drop sensors
- Autonomous vehicles

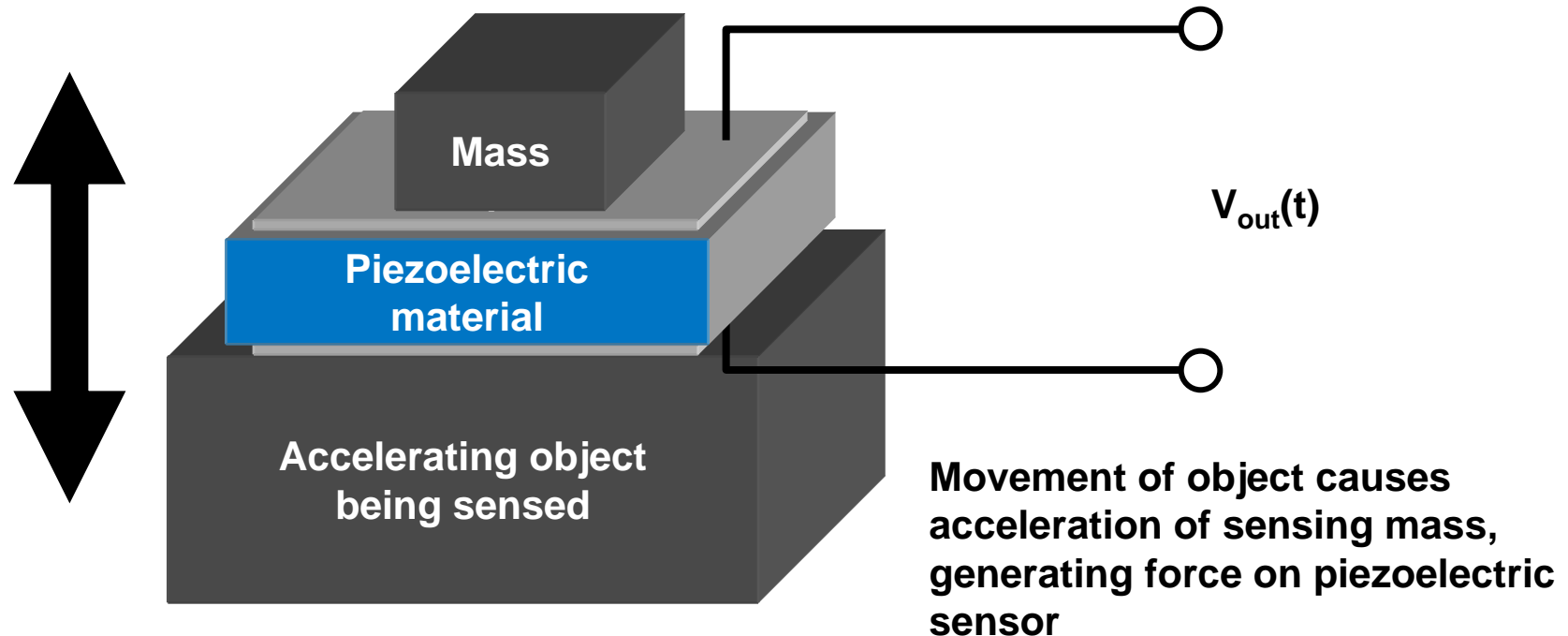

Acceleration Sensors

- Strain gauge accelerometers

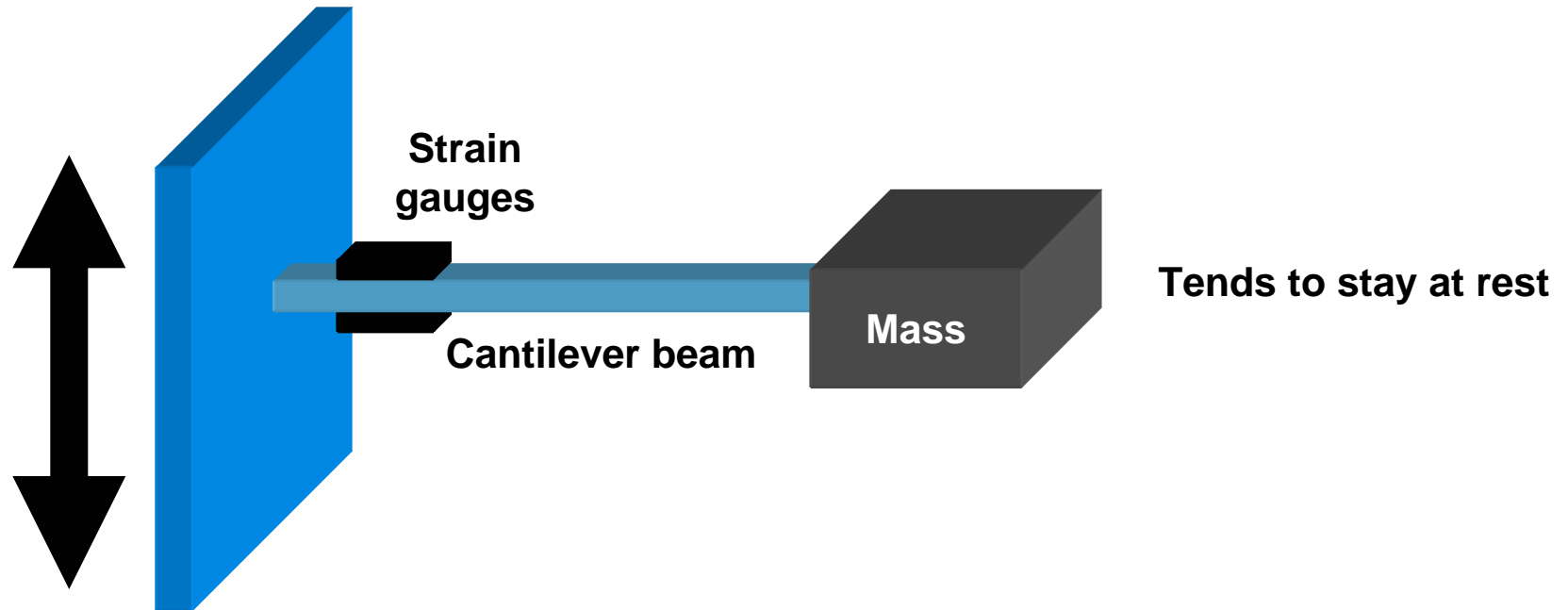

Force Sensors

- Cantilever beam

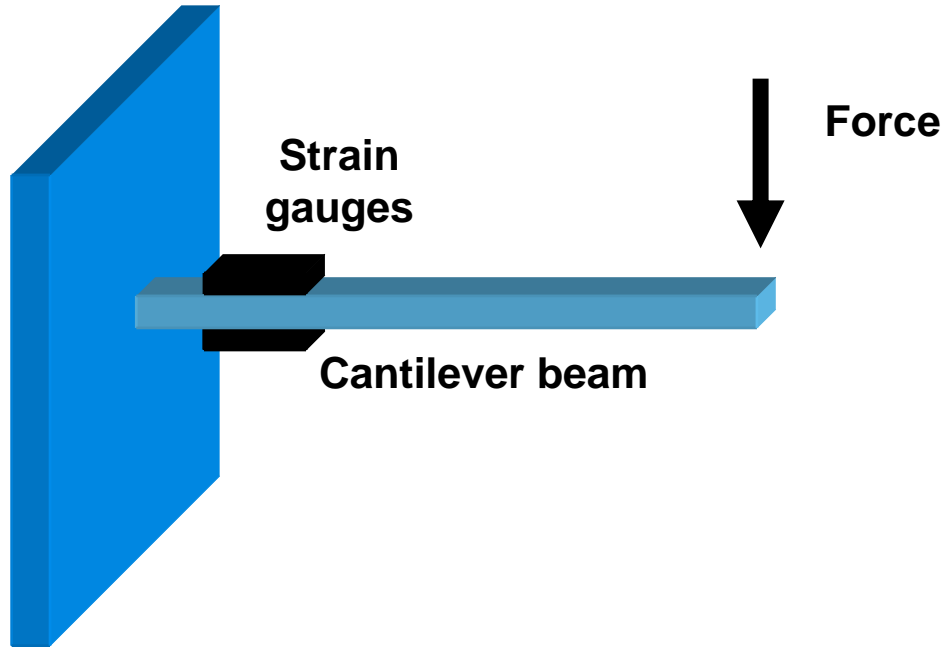

Force Sensor

- Hollow cylinder

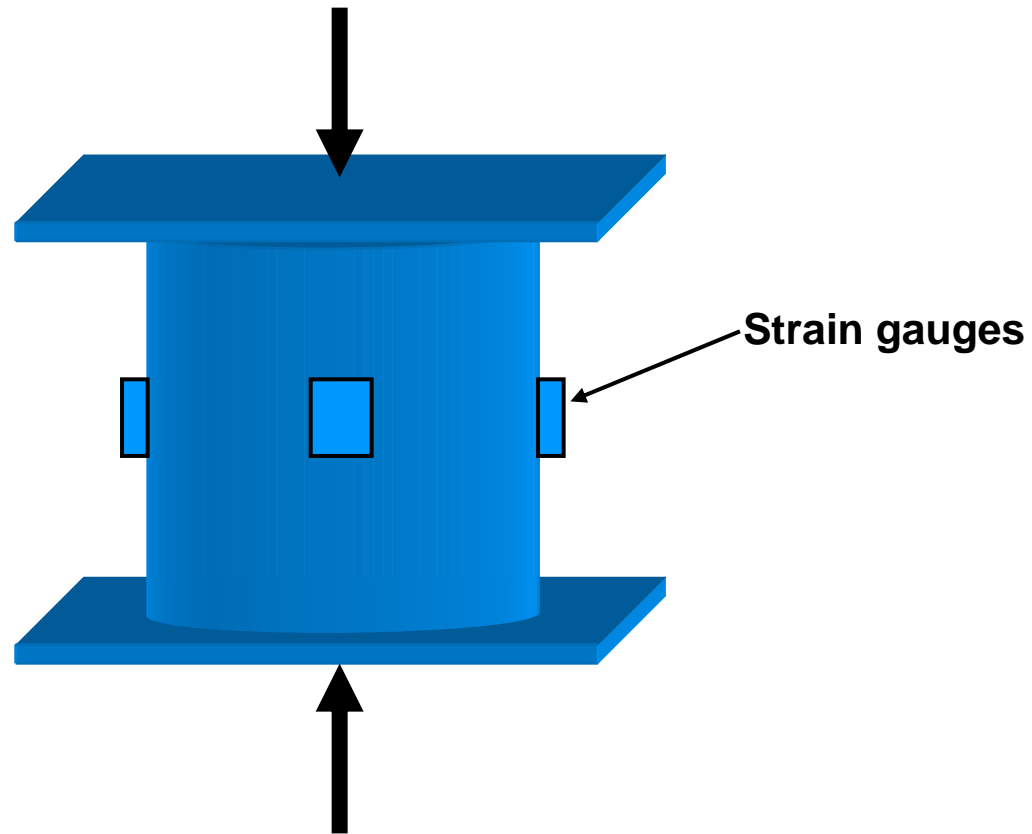

Torque Sensor

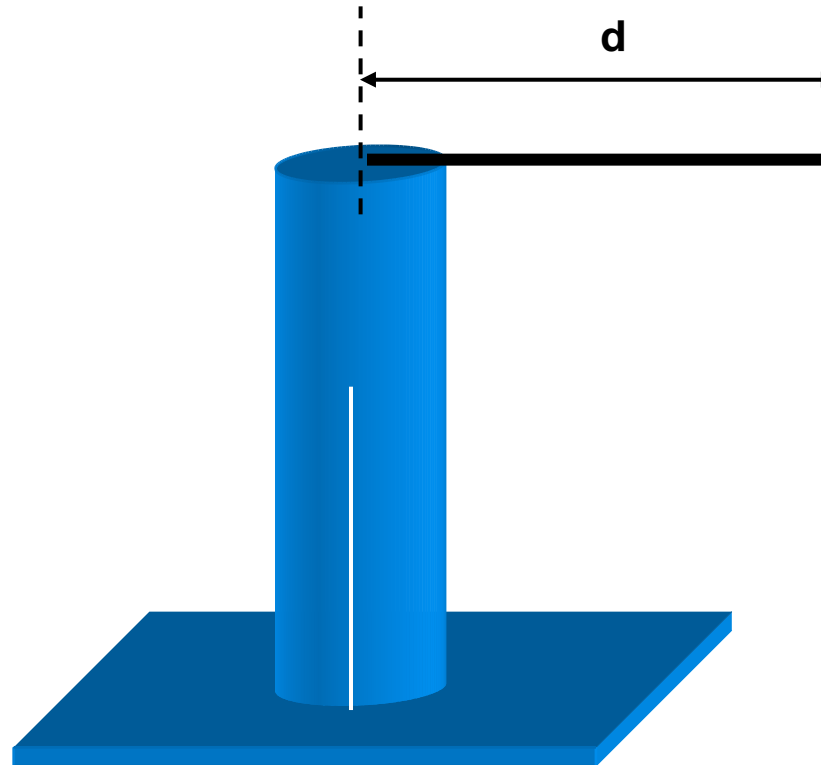

Torque Sensor

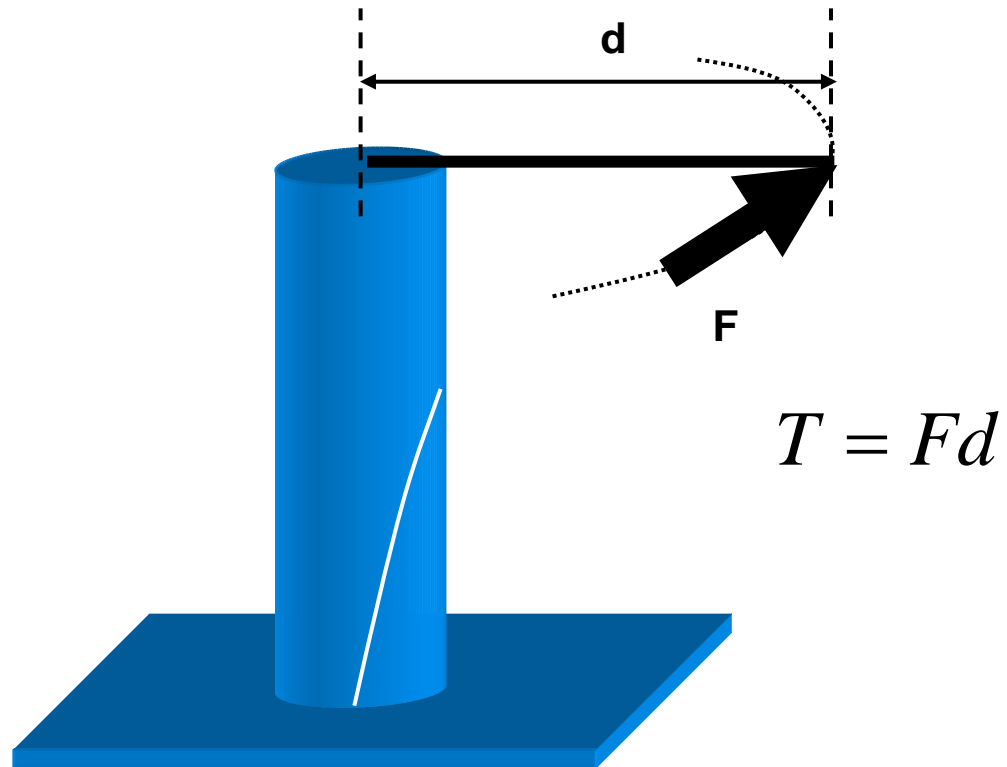

Torque Sensor

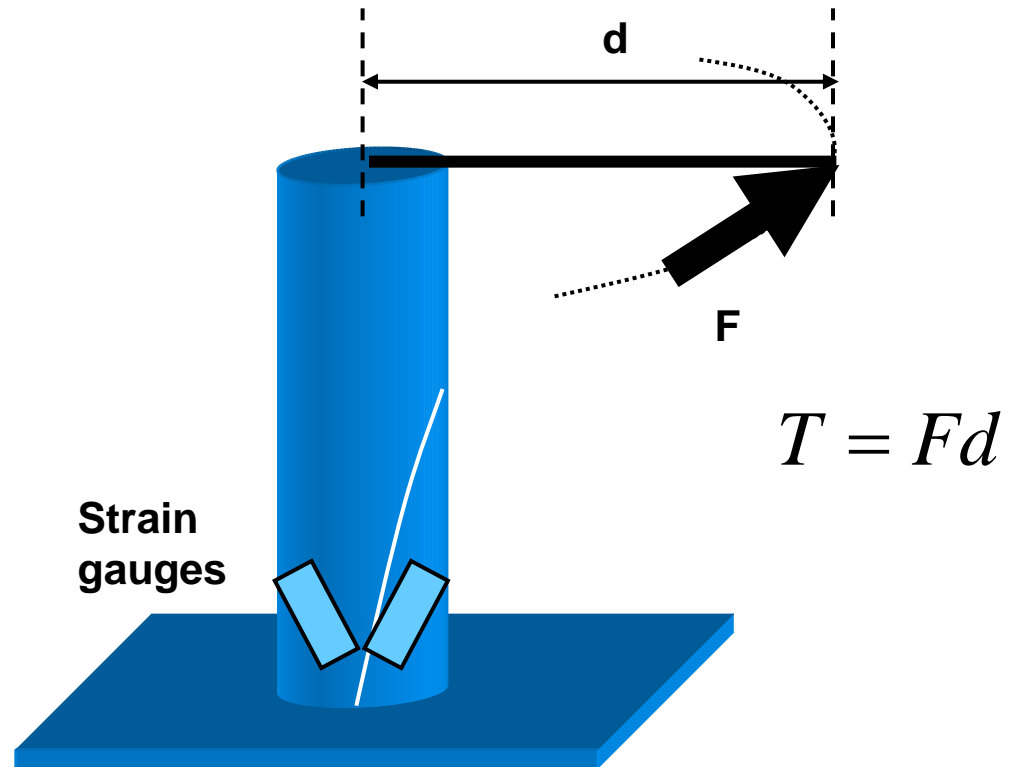

Next time

- More measurement sensors

Homework 7

- Problems 8.2, 8.7, 8.10, 8.27, 8.29