

Design IV

E232 Fall 07

Class 6

Bruce McNair
bmcnair@stevens.edu

Recorders/Indicators

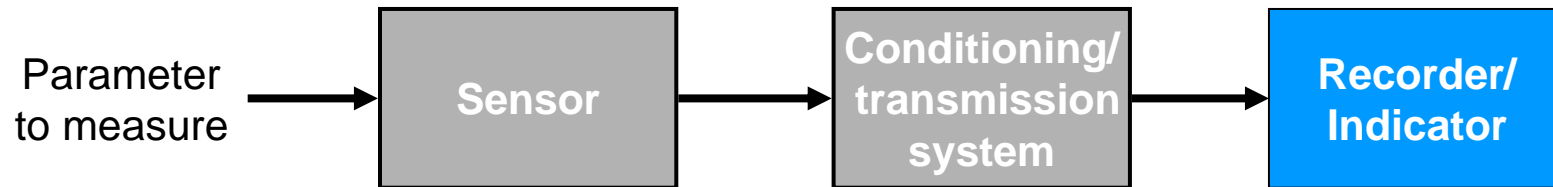

Recorders/Indicators

- Classical voltage (current) measurement

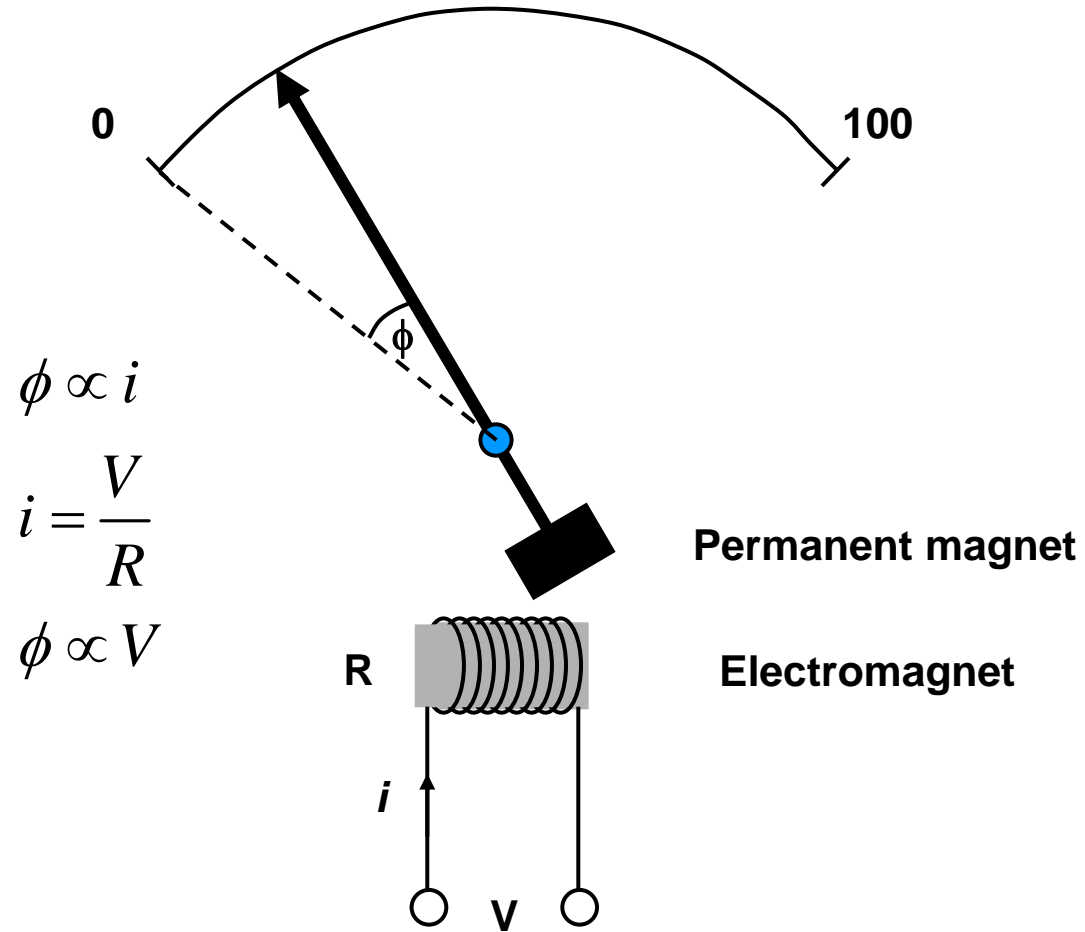

Recorders/Indicators

- Dynamic signal measurements – waveform displays: oscilloscope

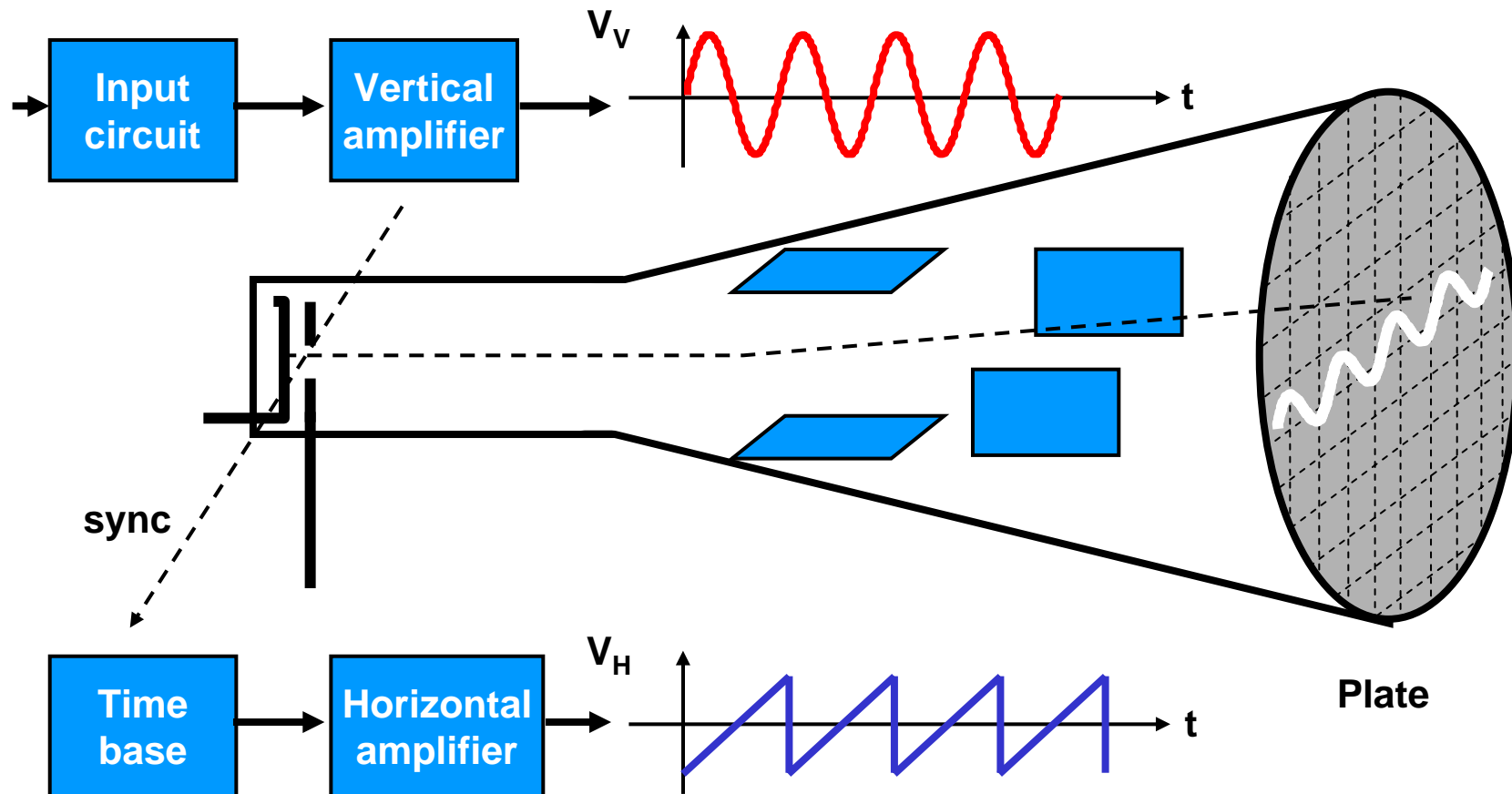

Recorders/Indicators

- Dynamic signal measurements – spectral displays: spectrum analyzer

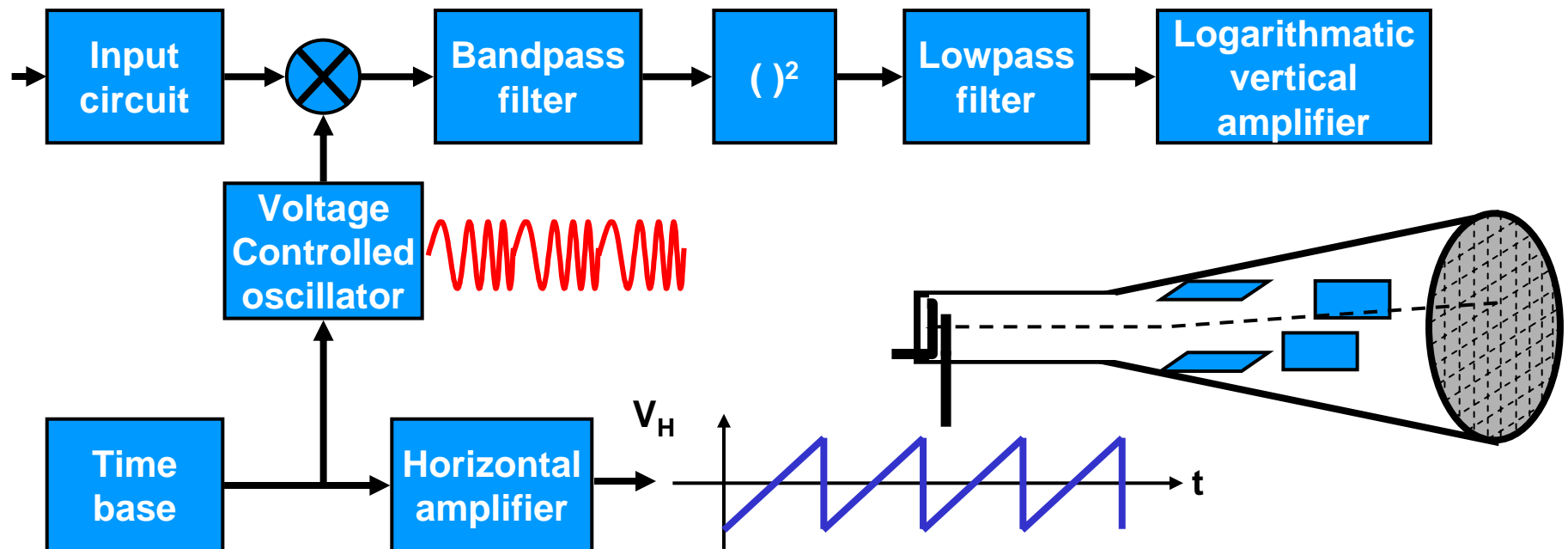

Today's topics

- Transmission
 - Signal level considerations
 - Interference sources
 - Ground loops
 - Rationale for digital signal transmission

Transmission System

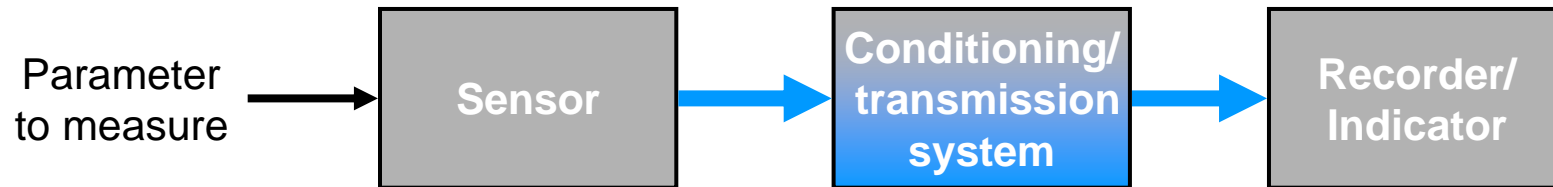

Transmission System

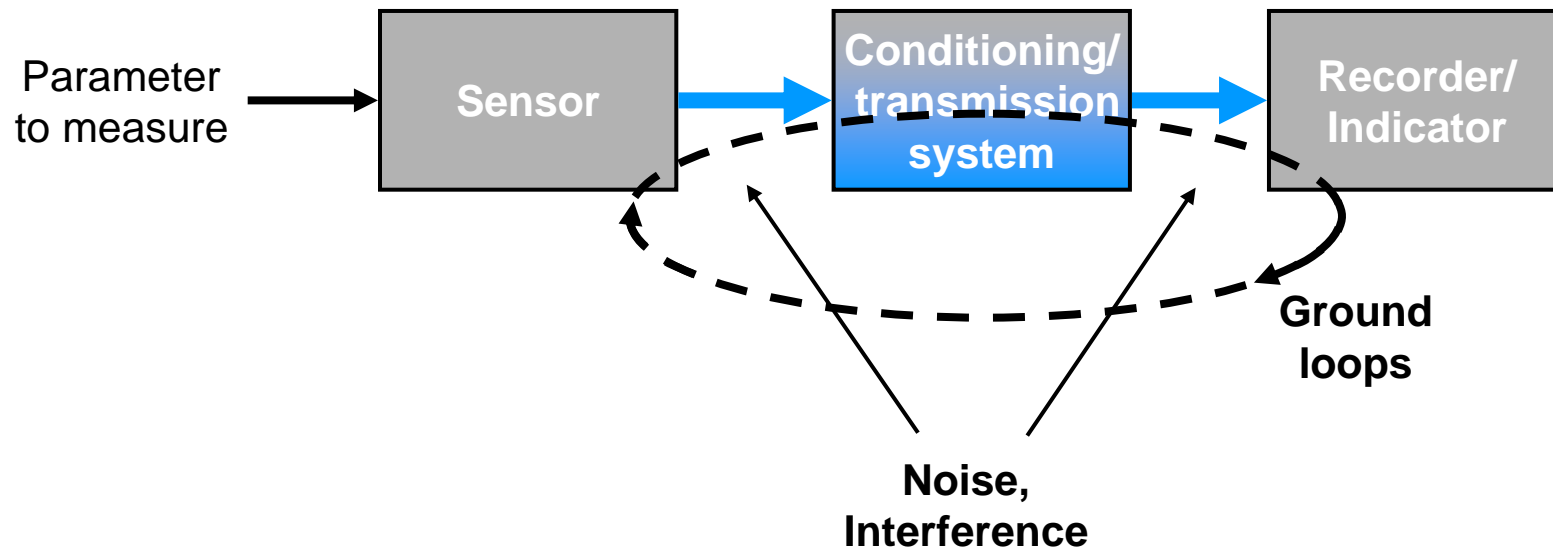

Transmission Systems

- Signal level considerations

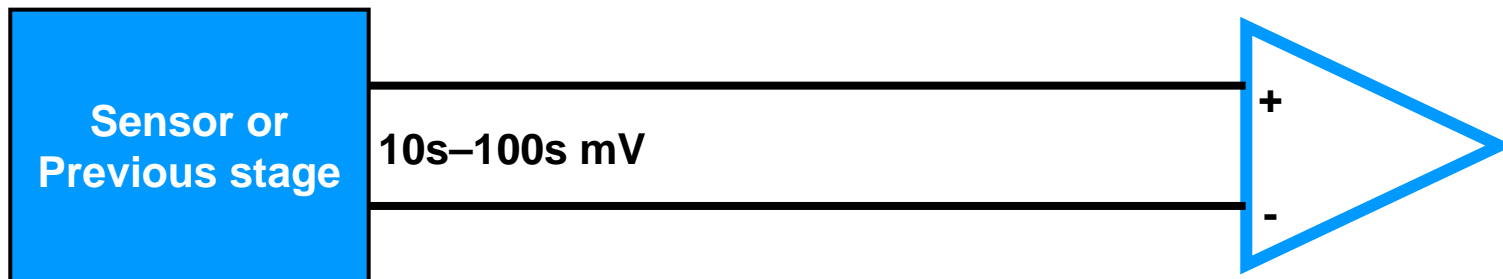

Transmission Systems

- Signal level considerations

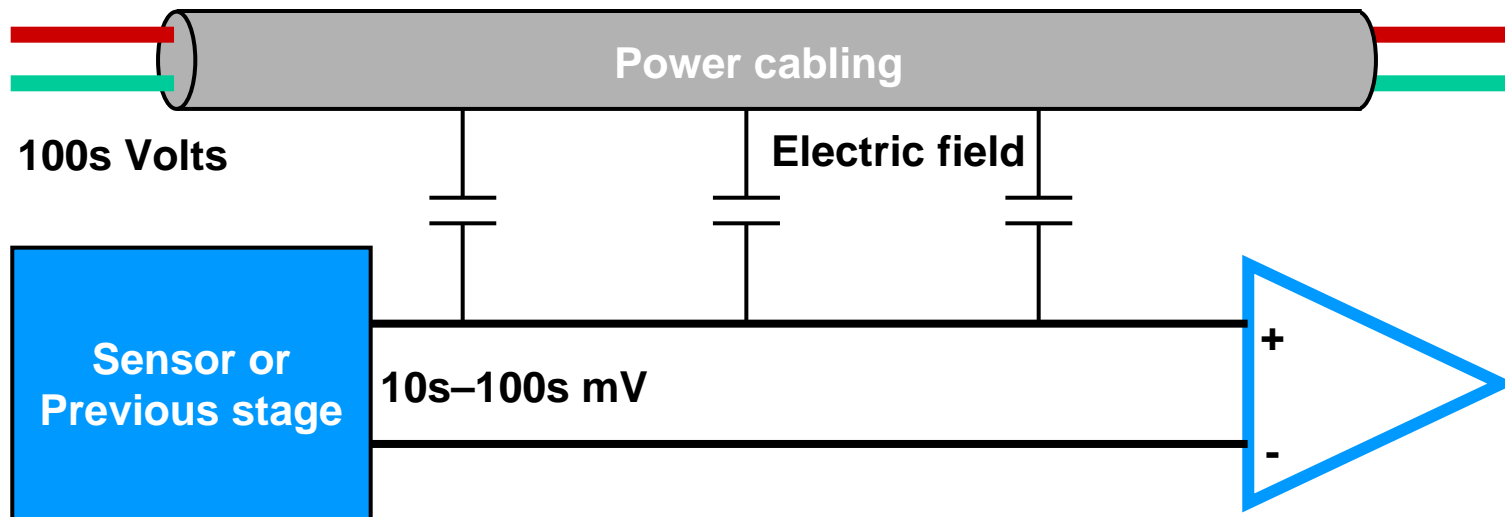

Transmission Systems

- Signal level considerations

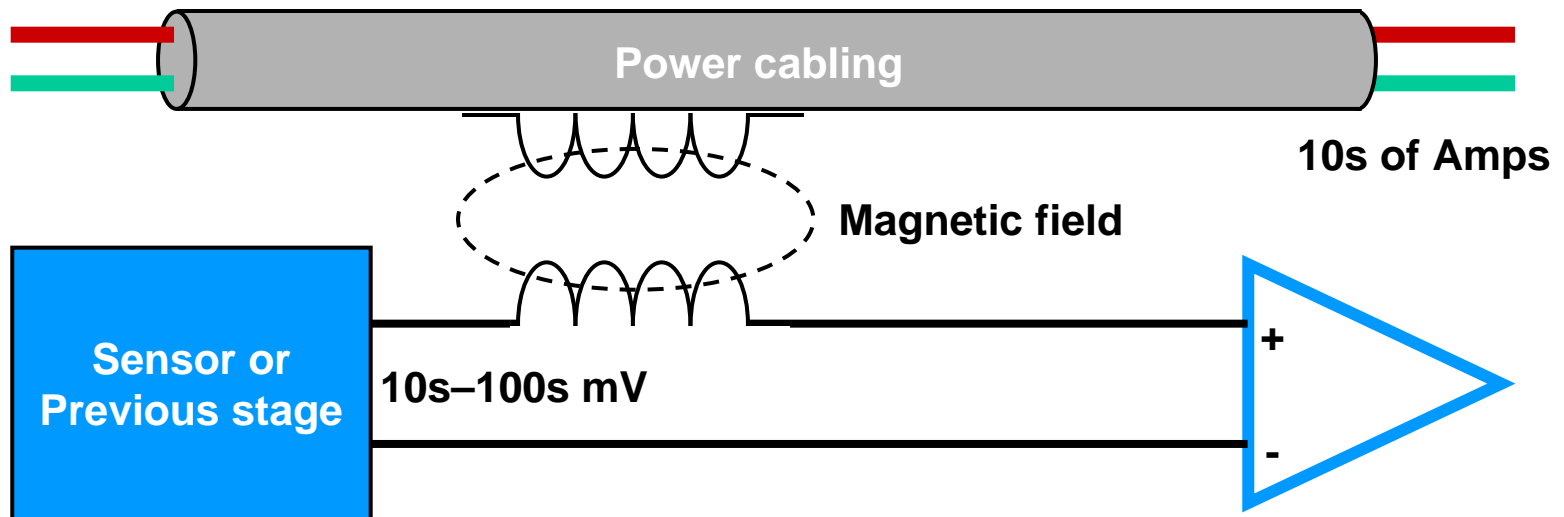

Transmission Systems

- Signal level considerations

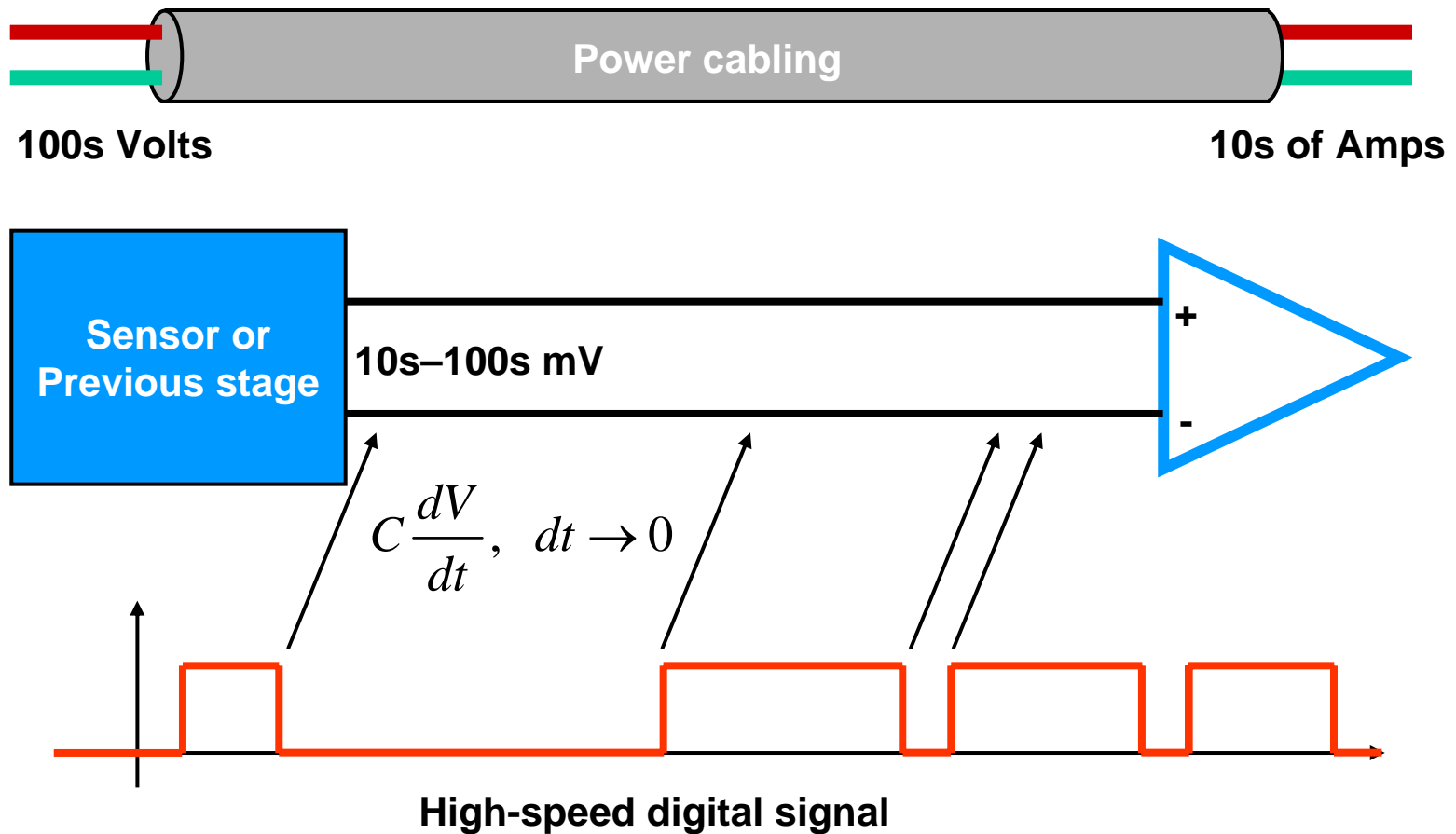

Transmission Systems

- Signal level considerations

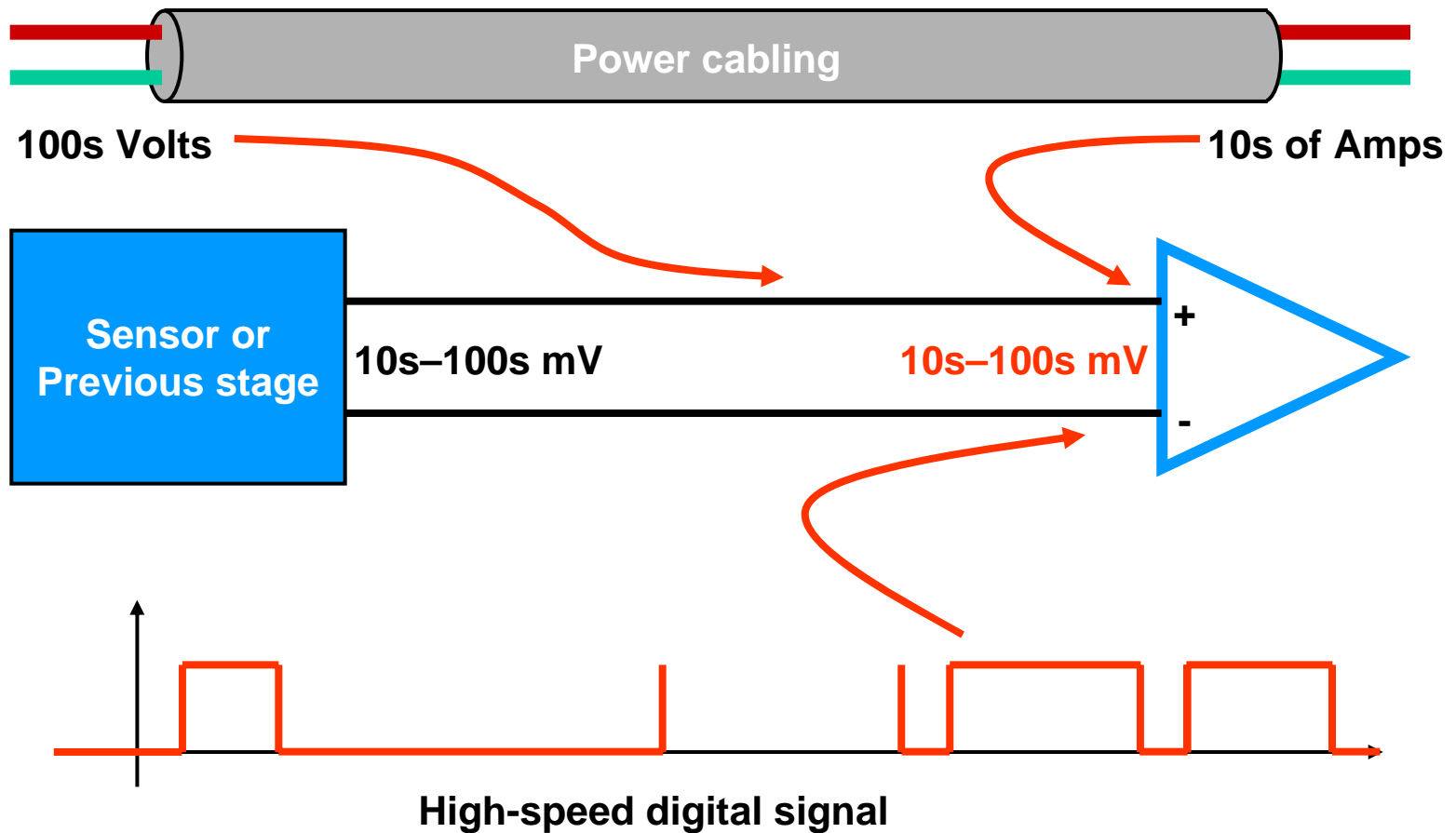

Transmission Systems

- Controlling interference

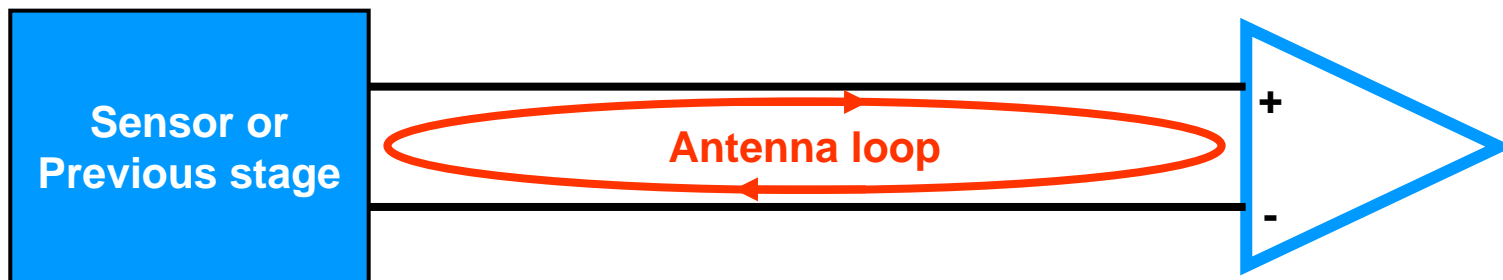

Transmission Systems

- Controlling interference

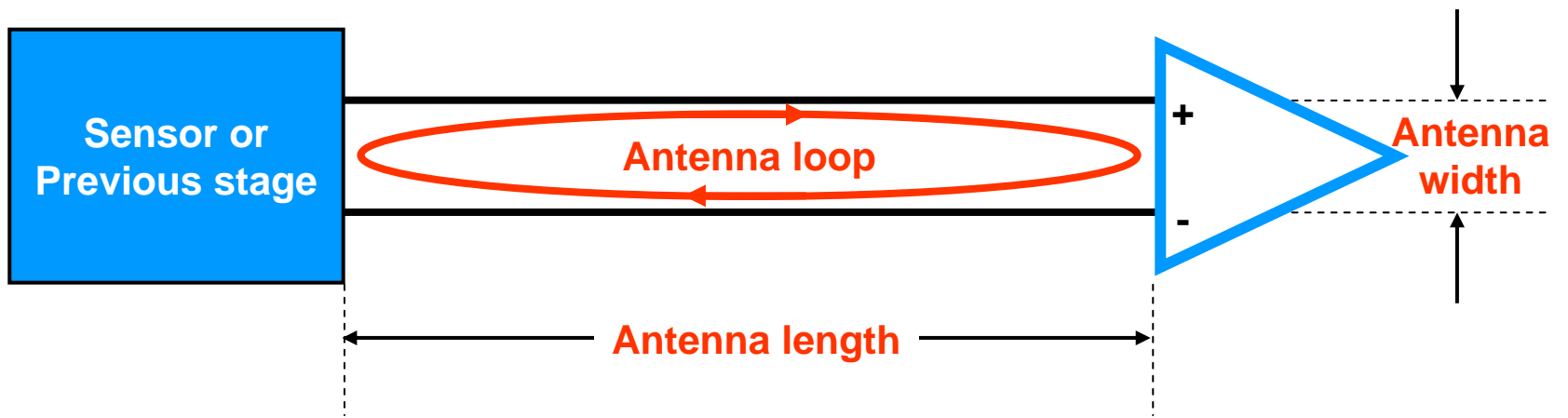

Interference pickup \propto antenna area

Transmission Systems

- Controlling interference with twisted pair cabling

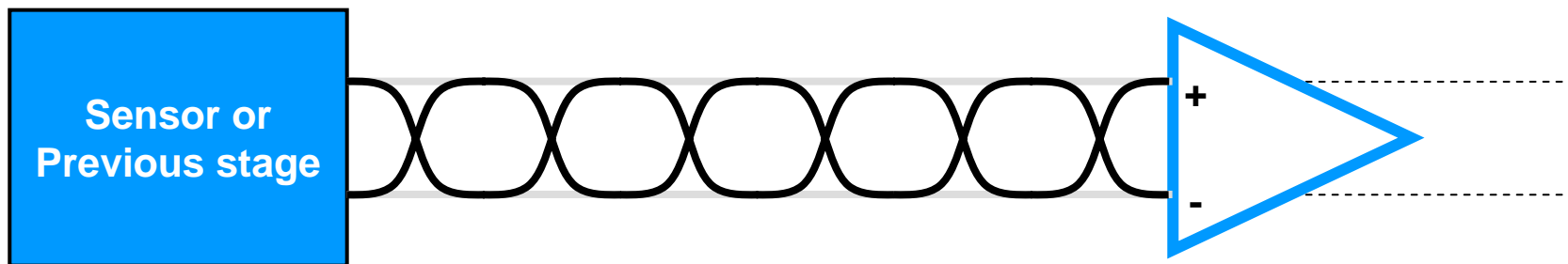

Interference pickup \propto antenna area

Transmission Systems

- Controlling interference with twisted pair cabling

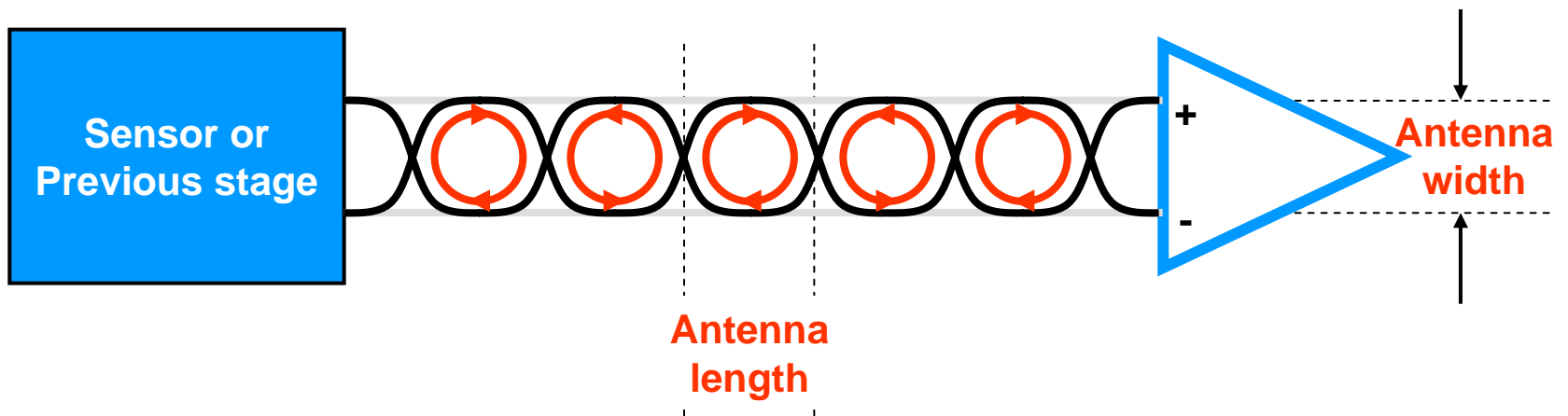

Interference pickup \propto antenna area

Transmission Systems

- Controlling interference with twisted pair cabling

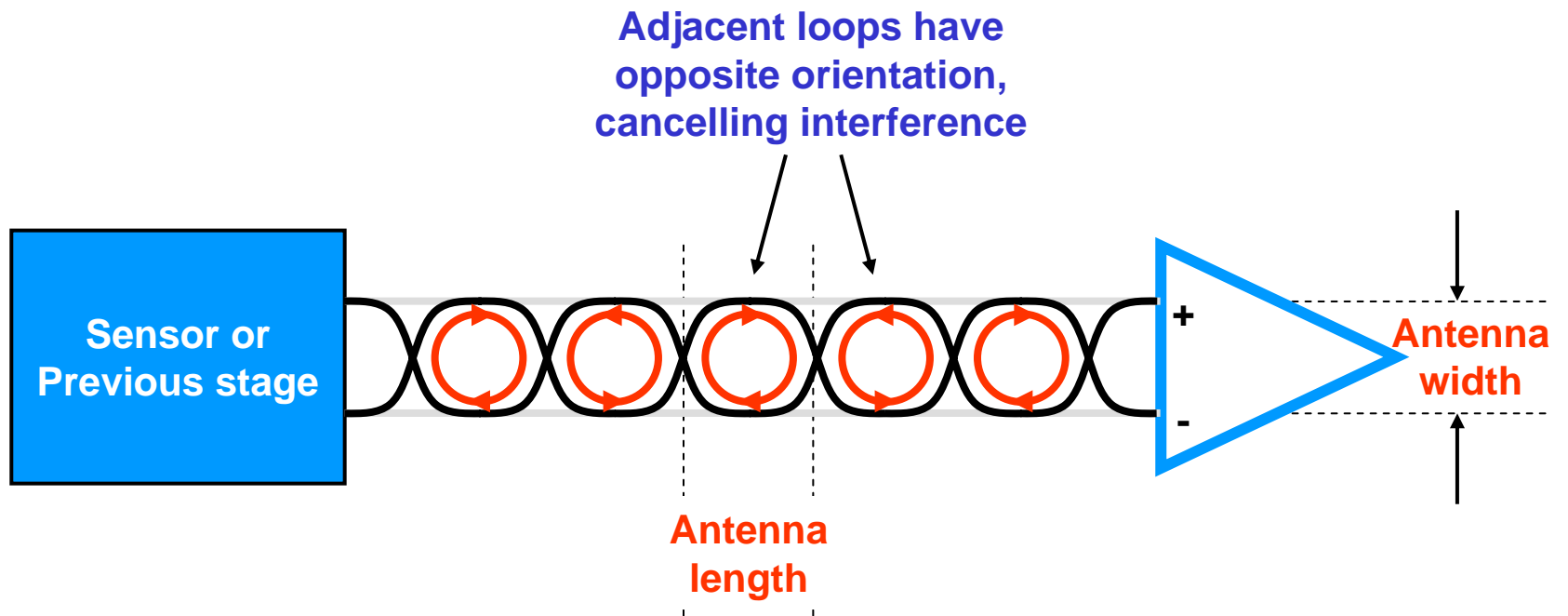

Interference pickup \propto antenna area

Transmission Systems

- Ground loops

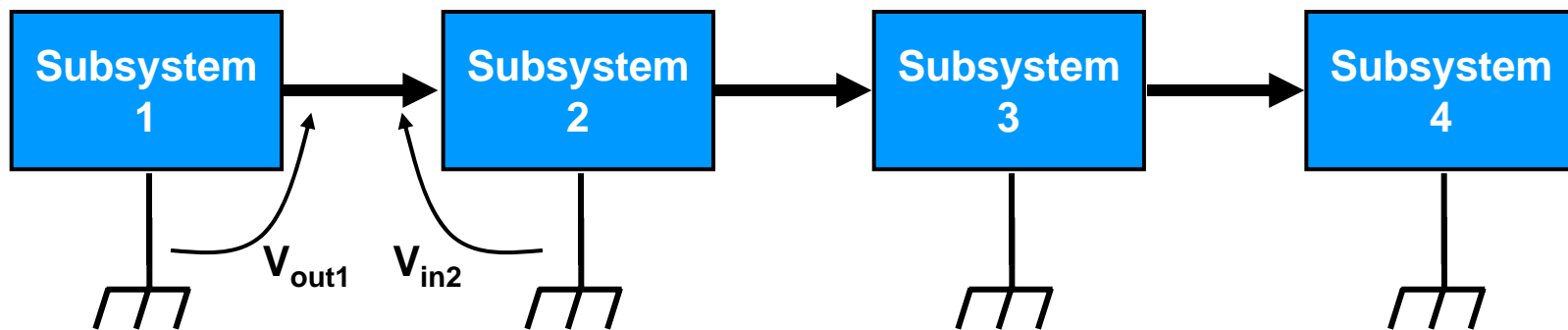

Transmission Systems

- Ground loops

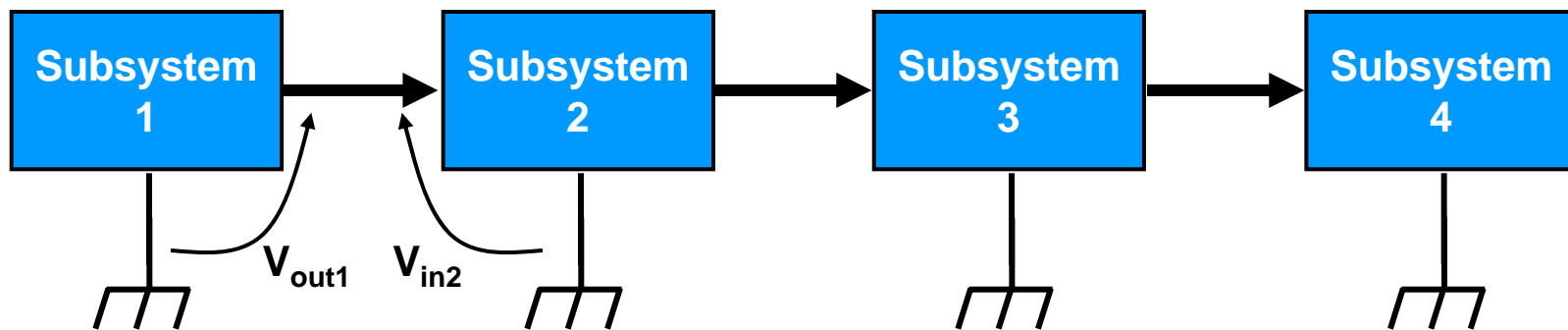

Why might V_{out1} and V_{in2} differ?

Transmission Systems

- Ground loops

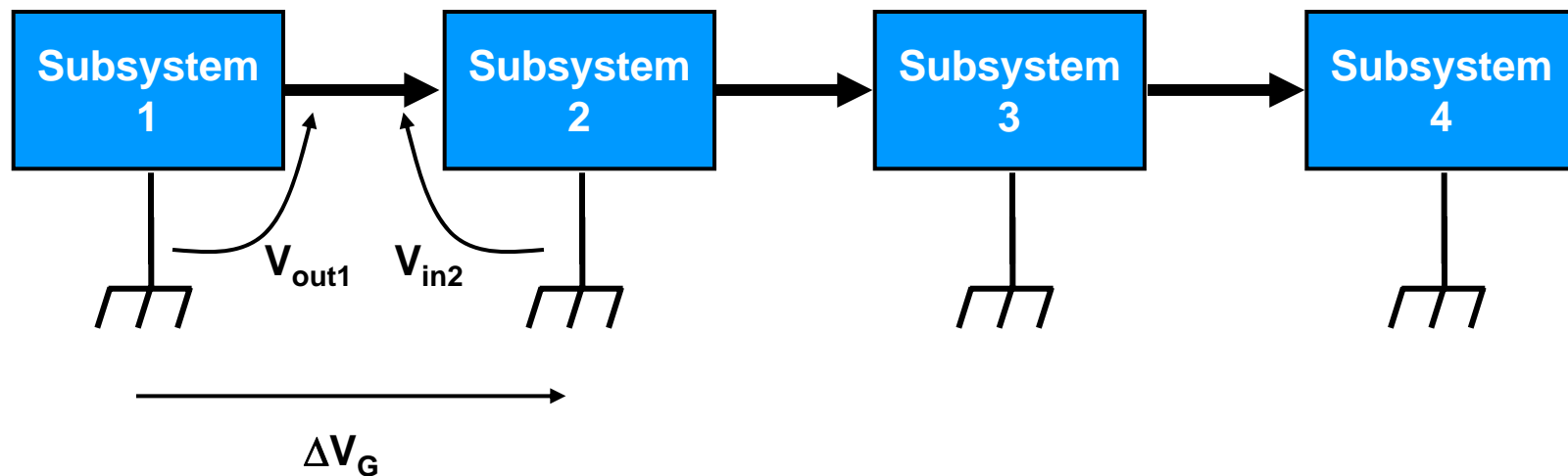

**Why might V_{out1} and V_{in2} differ?
Difference in ground voltage shows up as input noise.**

Transmission Systems

- Controlling ground loops

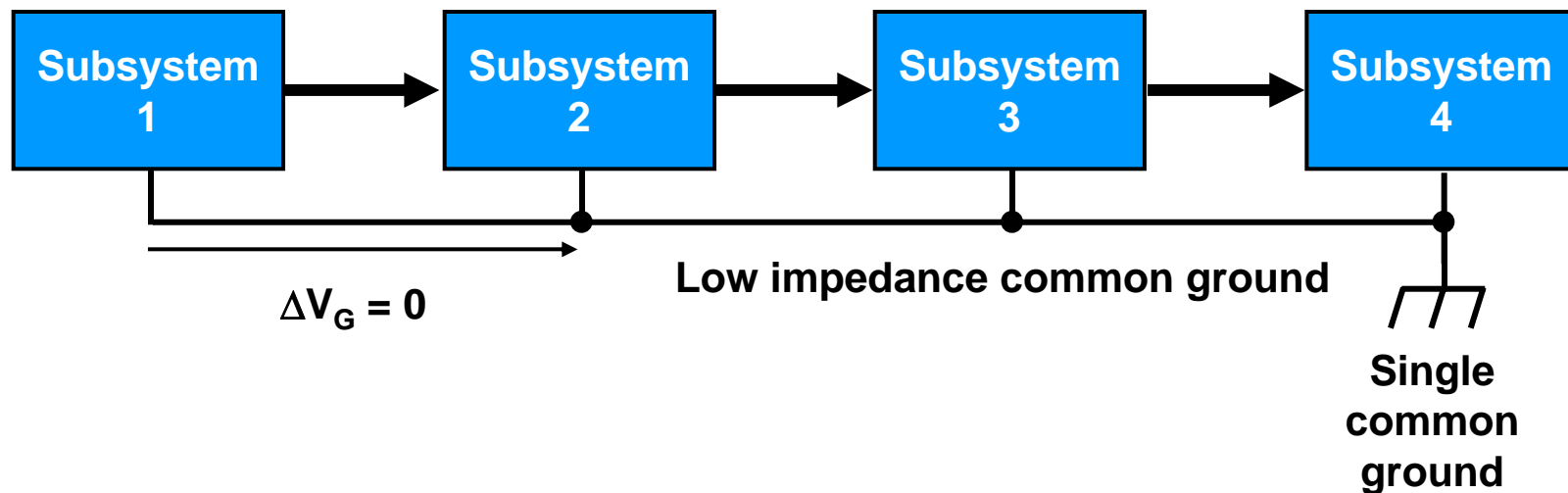

Transmission Systems

- Voltage vs. current transmission

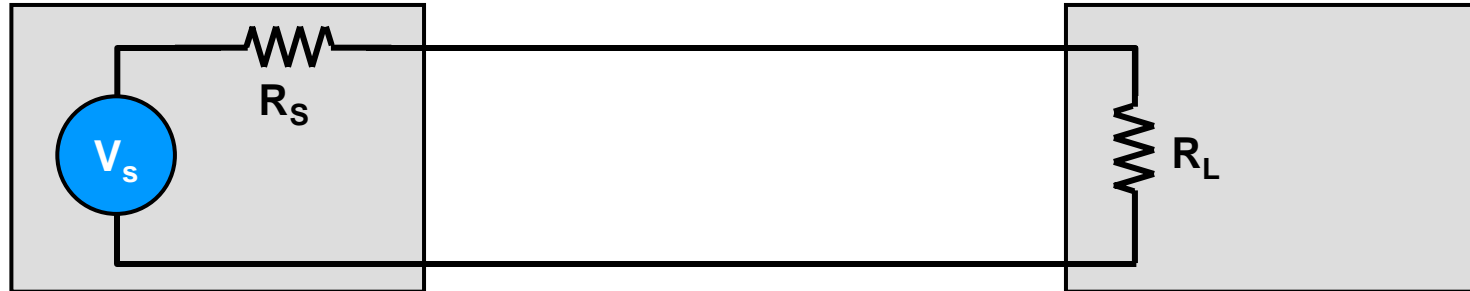

Maximizing R_L minimizes loading

Transmission Systems

- Voltage vs. current transmission

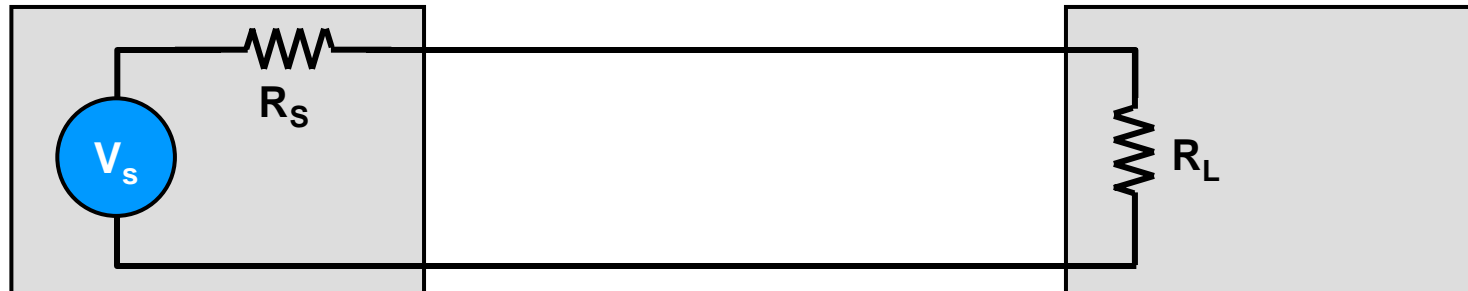

**Maximizing R_L minimizes loading
but maximizes susceptibility to interference**

Transmission Systems

- Voltage vs. current transmission

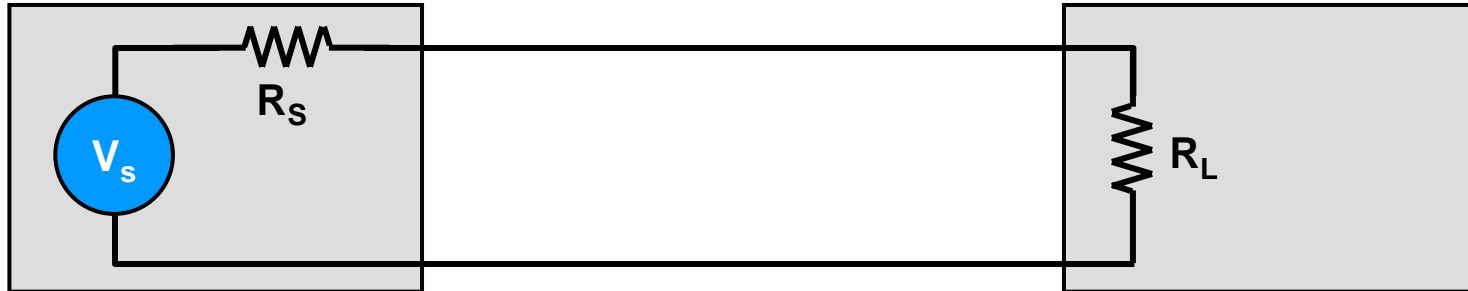

Maximizing R_L minimizes loading
but maximizes susceptibility to interference

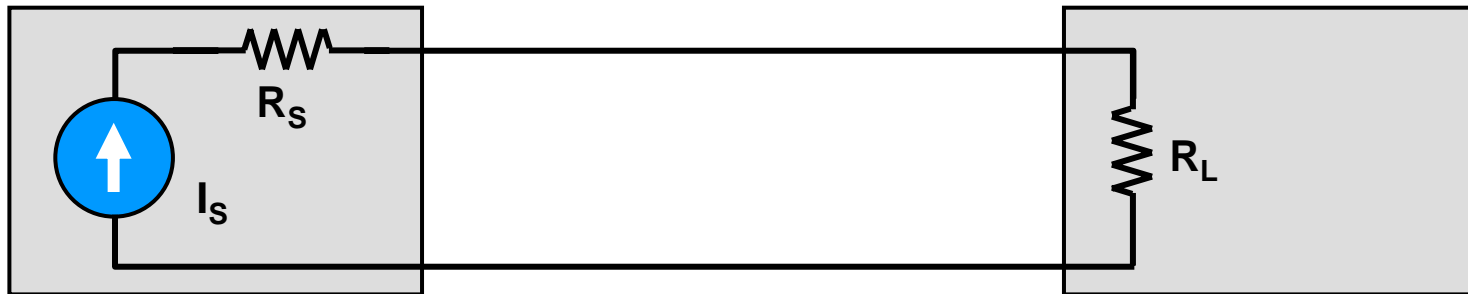

Smaller R_L can be used
reducing susceptibility to interference

Transmission Systems

- Analog signal transmission

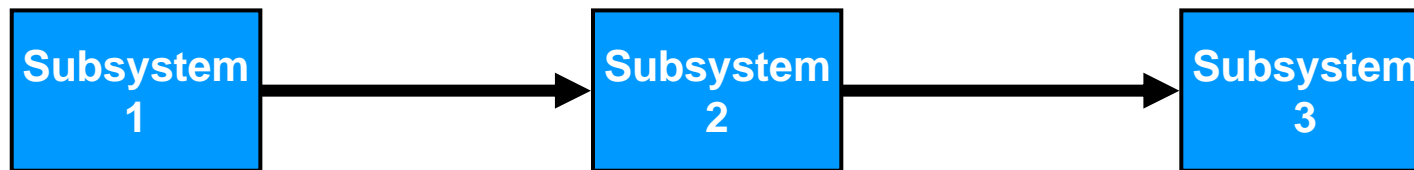

Transmission Systems

- Analog signal transmission

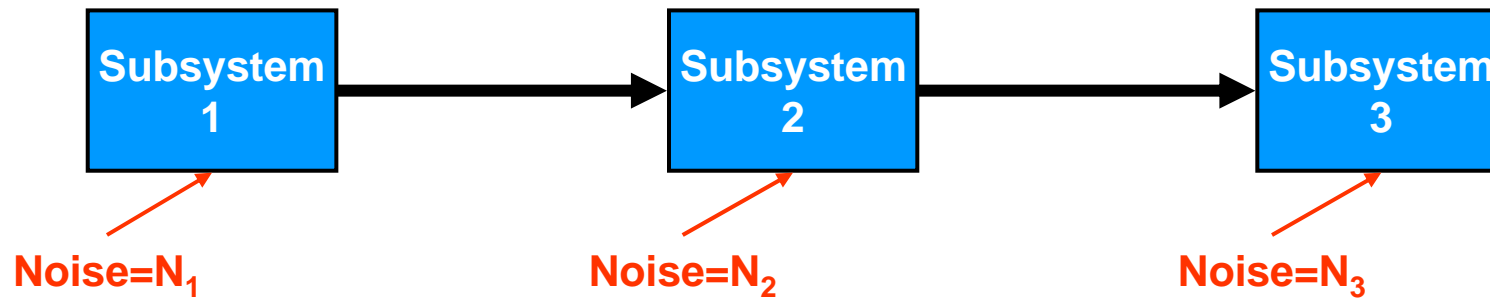

Transmission Systems

- Analog signal transmission

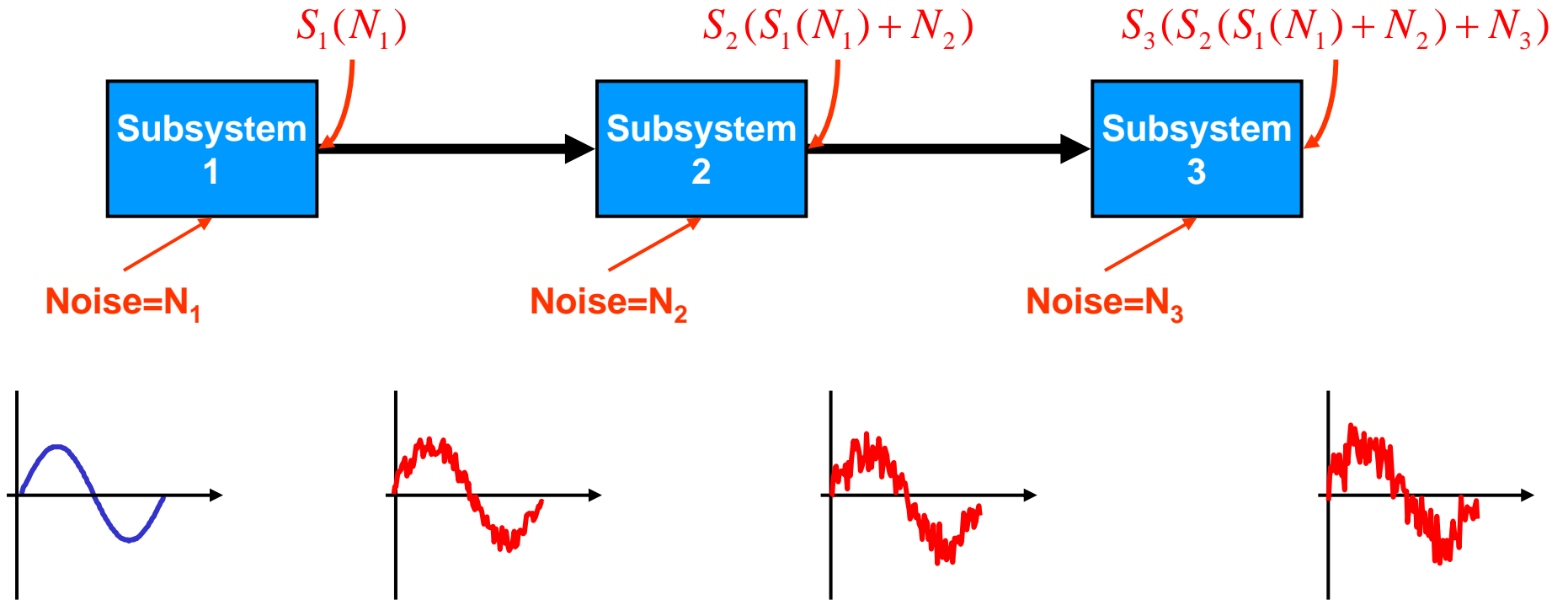

Noise from each stage combines with input noise and cannot be removed

Transmission Systems

- Digital signal transmission

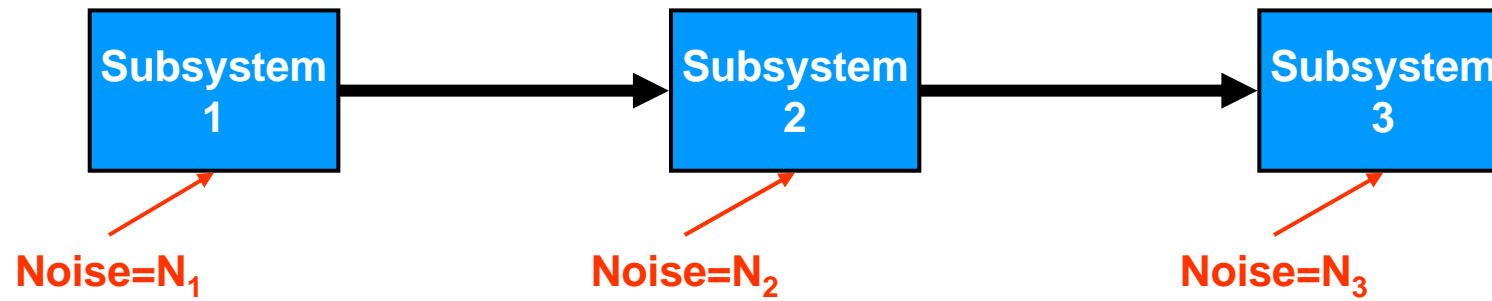

Transmission Systems

- Digital signal transmission

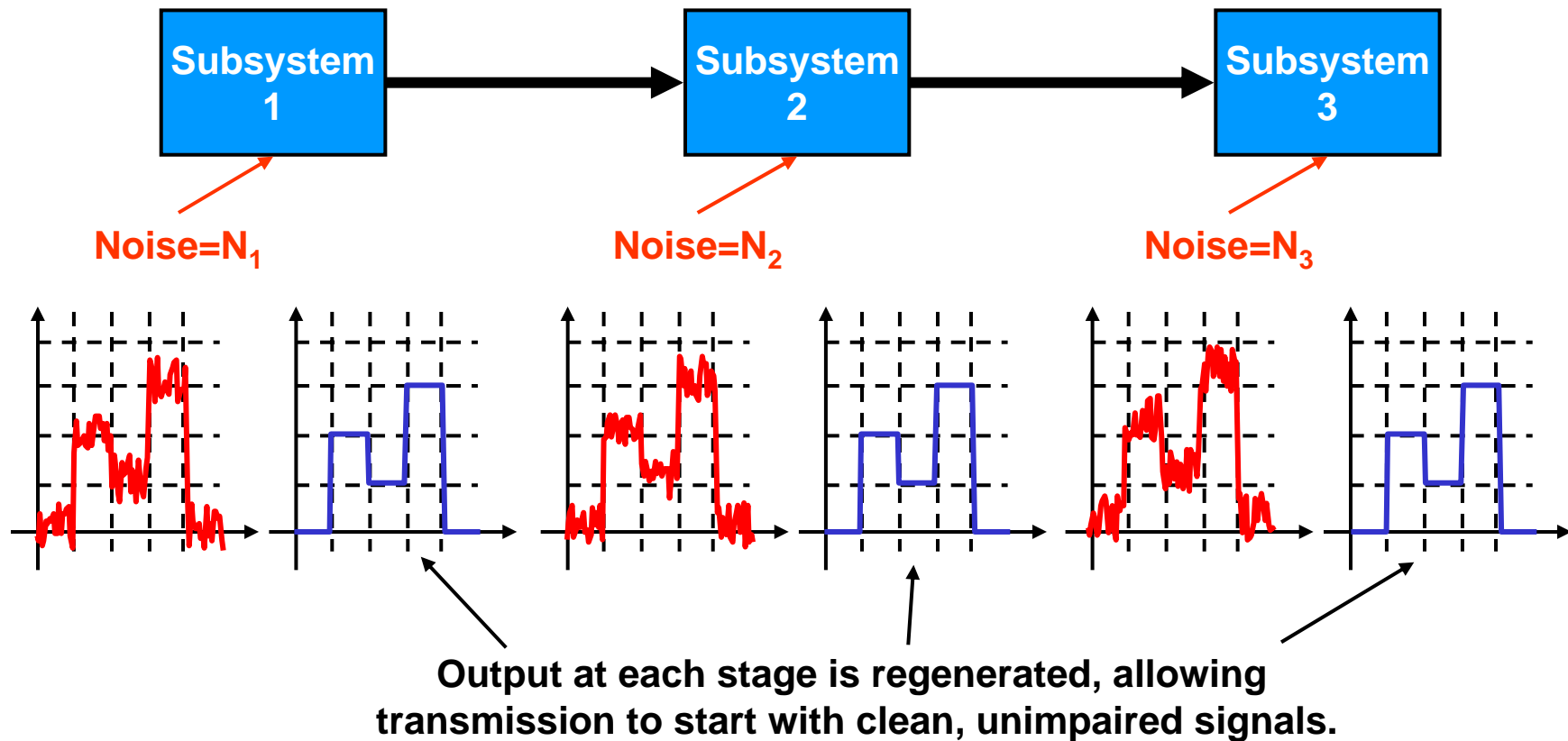

Signals change at established points in time, with specific allowed levels

Next topics

- Computerized Data Acquisition
 - Signal representation
 - Components
 - A/D conversion
 - Sampling
 - Quantization effects
 - Fourier Transform and frequency domain analysis

Homework 3

- Read Chapter 4
- Problems 3.17 (except the output is down 1.25 dB at 200 Hz), 3.24 (except the vertical sensitivity is 10 V/div), 3.25
- Show all work and indicate time spent on problems