

Modulation - baseband signals

- Consider a baseband signal, consisting of a few sinusoids. Examine the signal in the time domain and in the frequency domain:

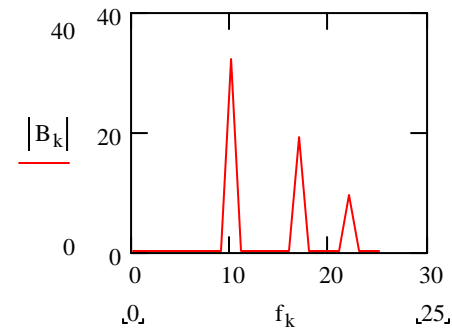
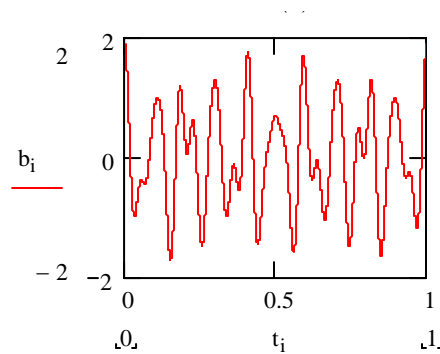

- This signal cannot be transmitted very far in its present format, nor can we allow multiple users to share the same spectrum, so the signal has to be modulated onto a “carrier”

Modulation - passband signals

- By “translating” the previous signal to a “carrier” frequency, we obtain a passband signal:

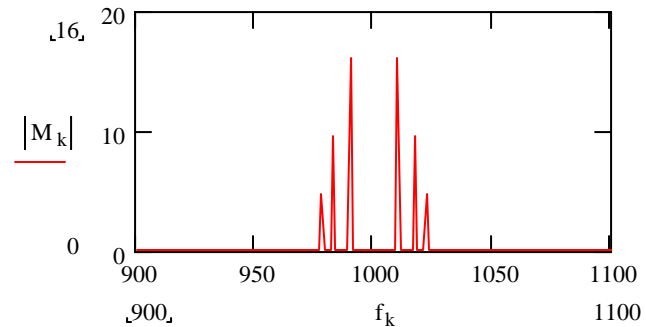
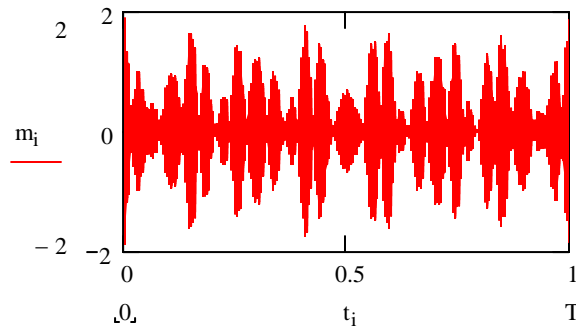

- This signal has all of its energy near the carrier frequency, in this case 1000 Hz

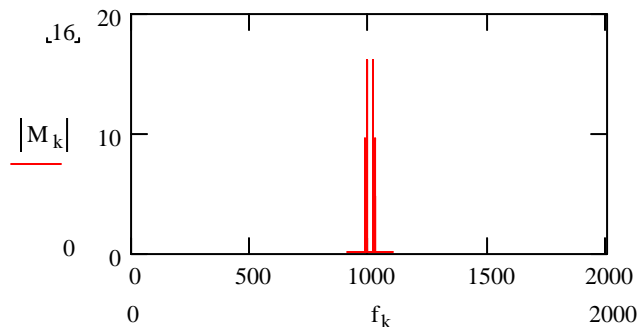

Modulation - a generic communications system

- Consider a simple communications system:

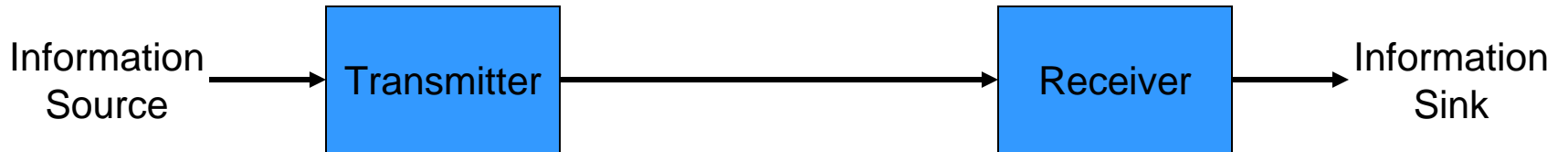

Modulation - a generic communications system

- Consider a simple communications system:

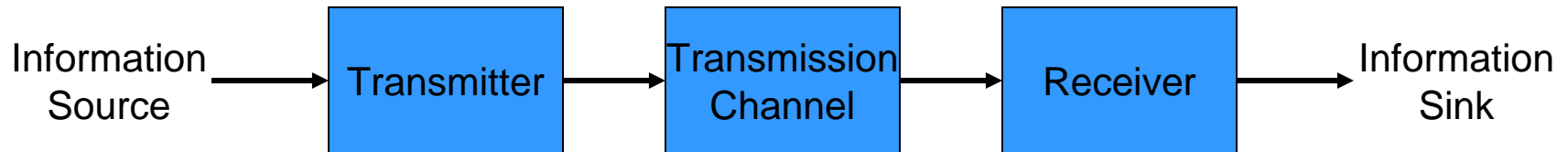

Modulation - a generic communications system

- Consider a simple communications system:

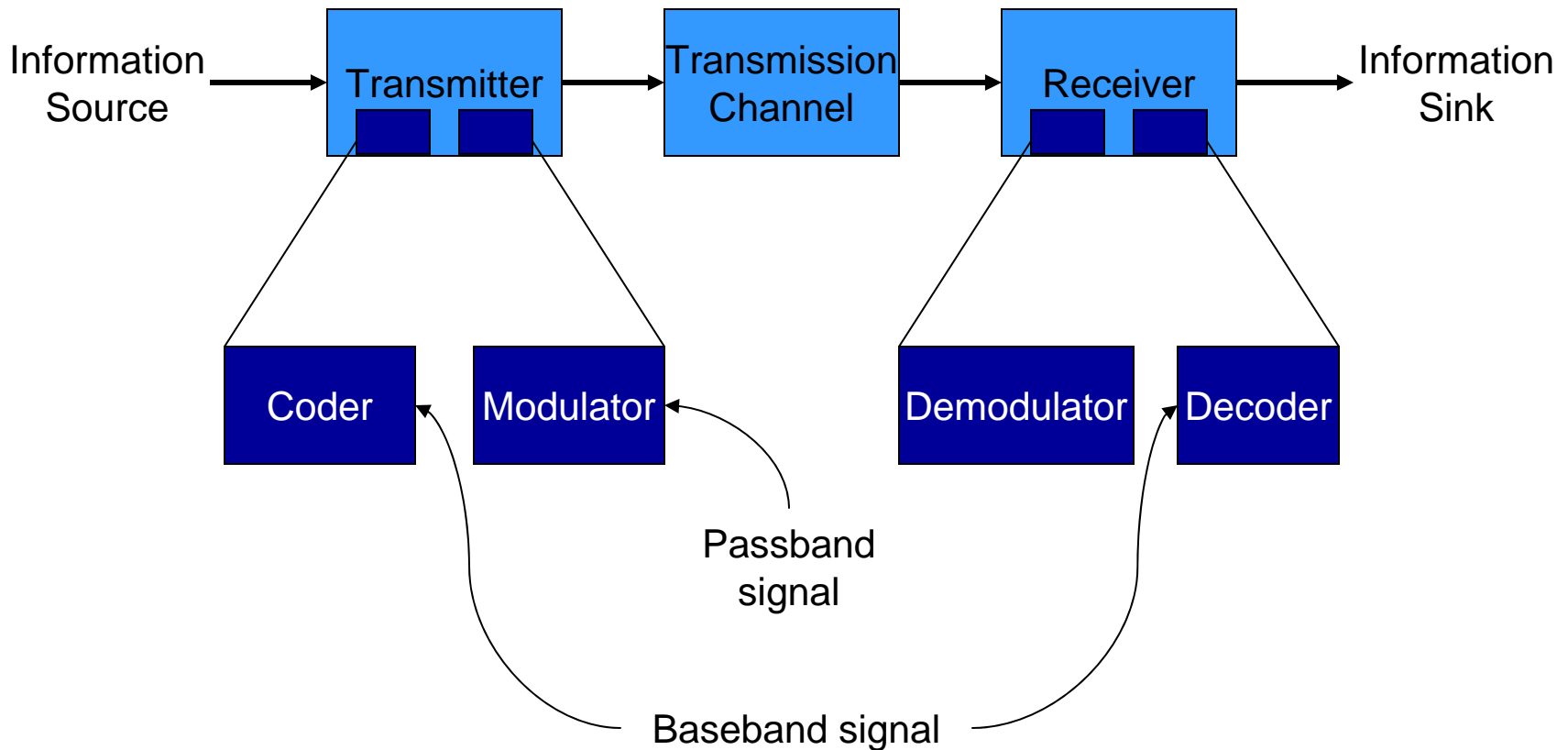

Modulation - modifiable signal parameters

- Consider a generic equation for a modulated signal $m(t)$, generated by a baseband signal $b(t)$. Start with an unmodulated carrier signal:

$$m(t) = A_c \cos(\omega_c t + \phi_c)$$

- we can modulate the carrier's
 - amplitude (as set by m_A)
 - frequency (as set by m_f), or
 - phase (as set by m_p)

Or multiple parameters could be modulated simultaneously

$$m(t) = A_c [1 + m_A b(t)] \cos((\omega_c + m_f b(t))t + m_p b(t) + \phi_c)$$

Analog modulation - AM

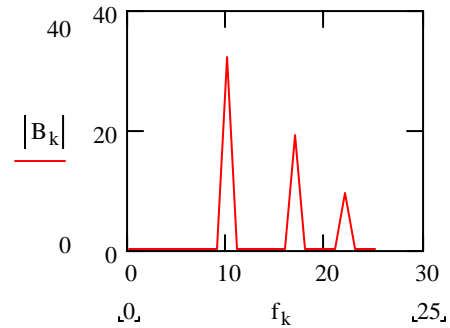
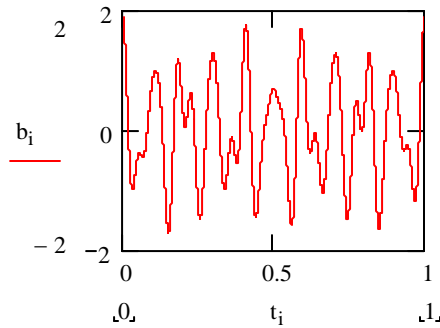

- With the baseband signal as before, set m_A to 1 (100% modulation) and the other modulation parameters to zero to obtain a purely AM signal

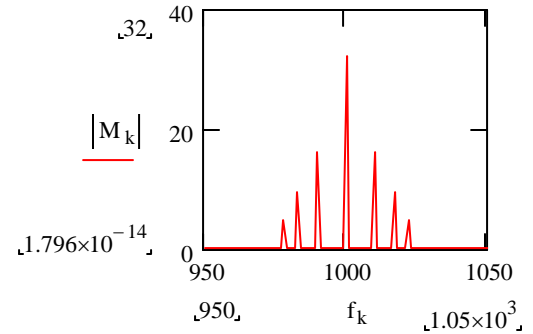
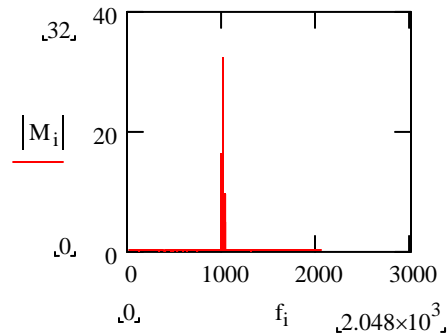
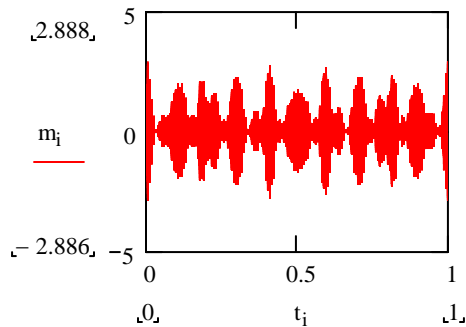

Detecting AM

- There are two types of AM detectors:
 - envelop detectors

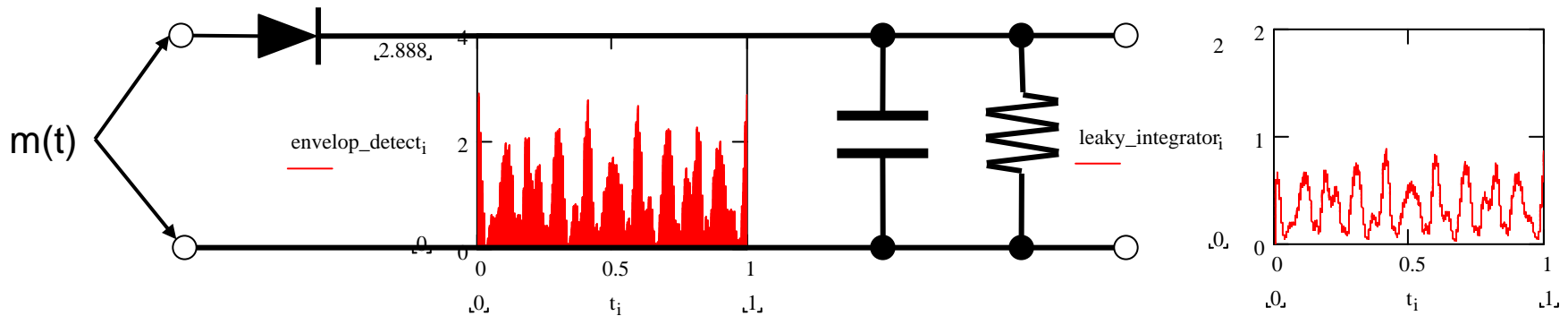

- and synchronous detectors

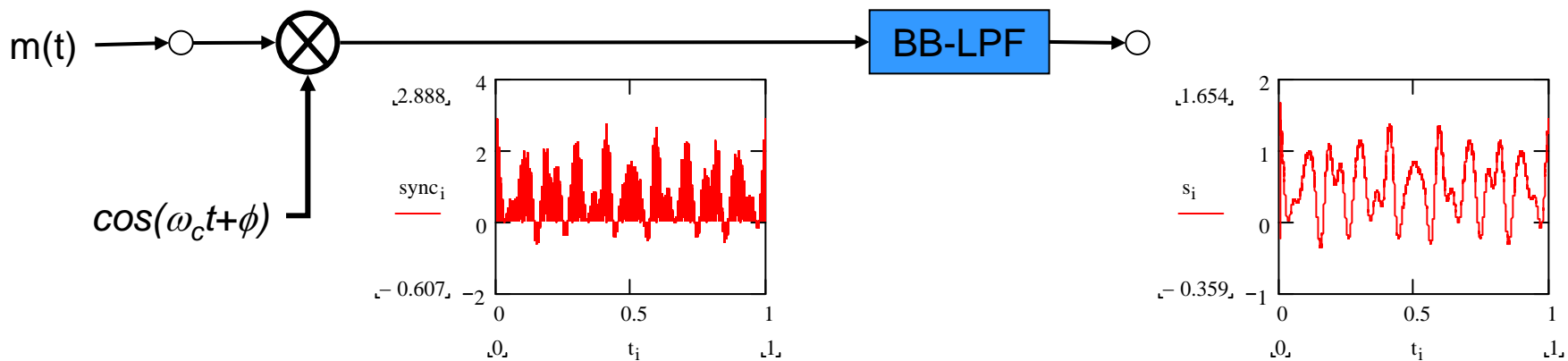

FM and PM

- FM and PM can be thought of as the same modulation technique with proper choice of the input signal:
 - Define the instantaneous phase of a sinusoid:

$$\phi(t) = \int_{-\infty}^t \omega(x) dx$$

- so, by integrating the modulating waveform presented to a phase modulation system, we have a frequency modulation system. And conversely, by differentiating the input to a frequency modulated system, we have a phase modulated system.

Bandwidth requirements of FM/PM systems

- Again, consider the earlier baseband modulating signal, this time frequency modulating the carrier.

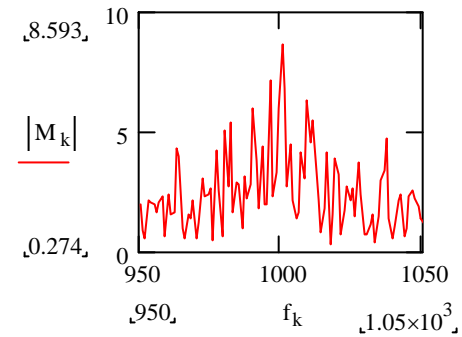
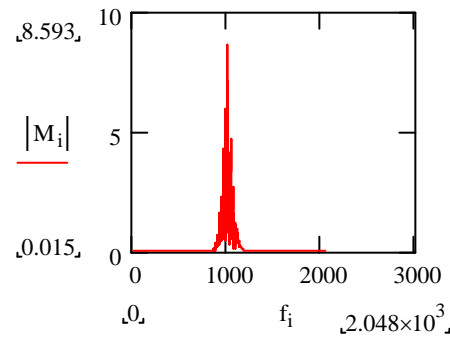
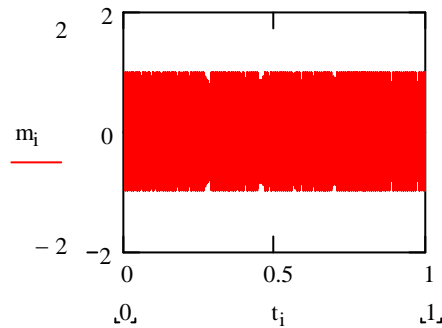

Bandwidth requirements of FM/PM systems

- An FM signal with a simple sinusoidal modulating waveform

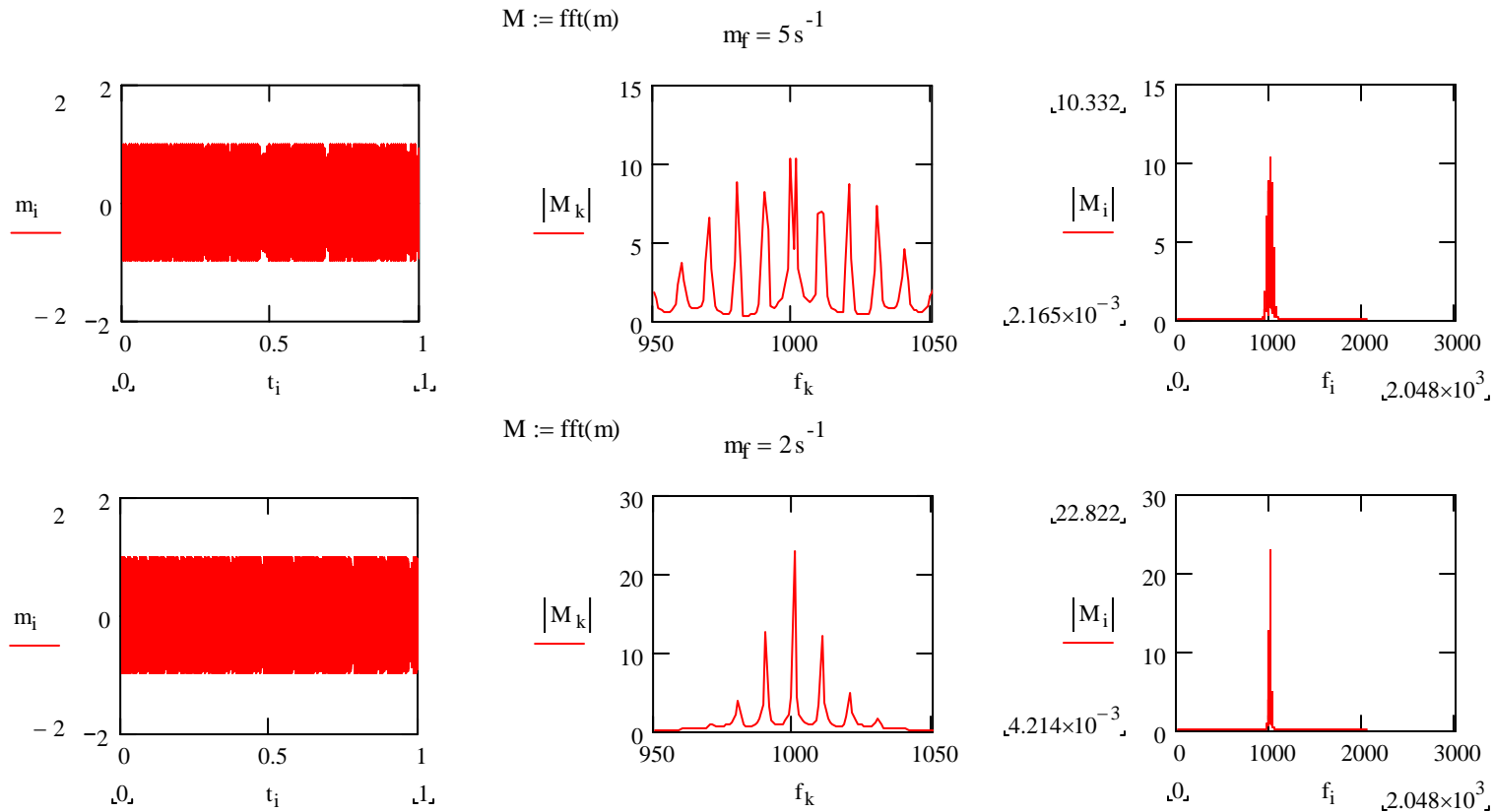

Modulating an FM signal

- Generic FM modulator:

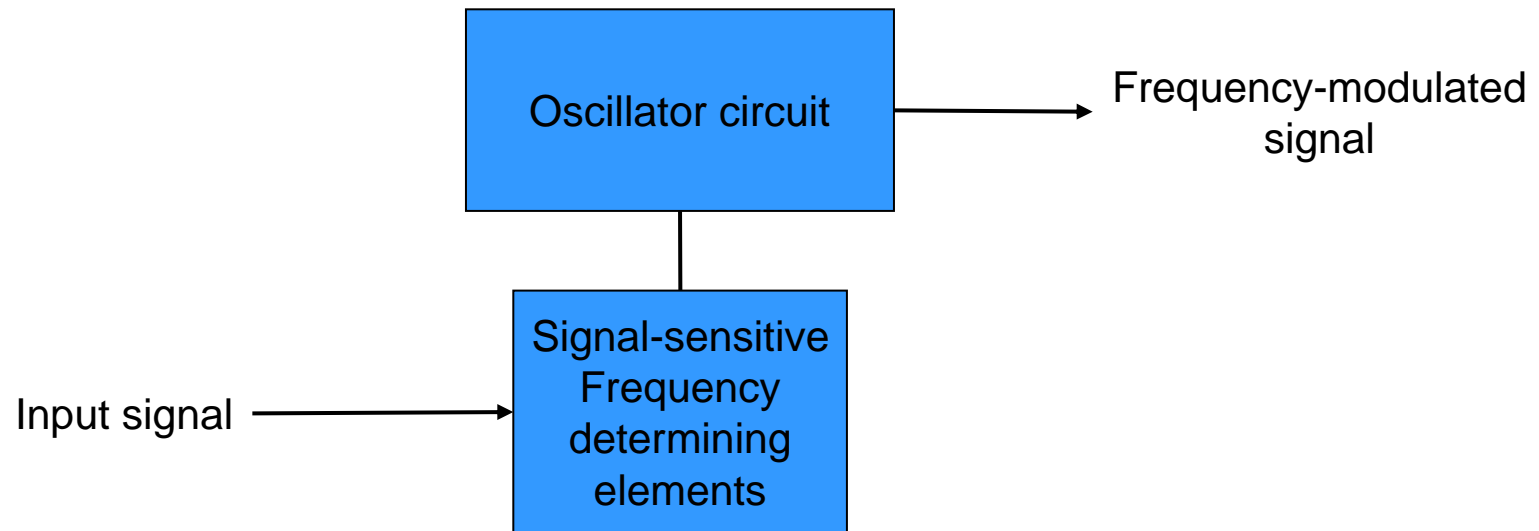

Demodulating FM

- Generic FM demodulator:

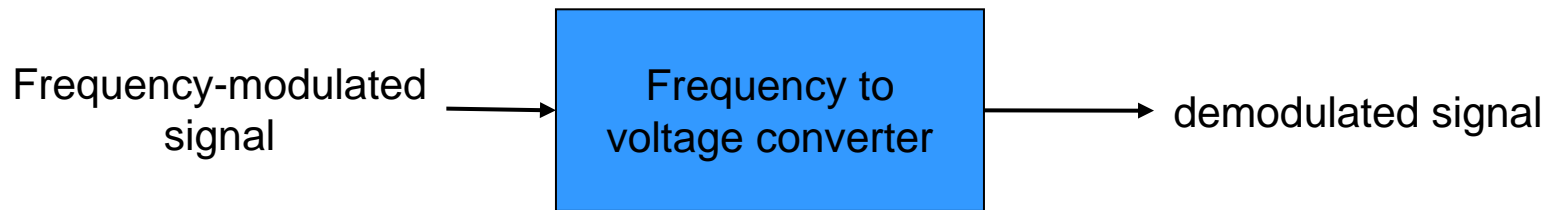

Demodulating FM

- Generic FM demodulator:

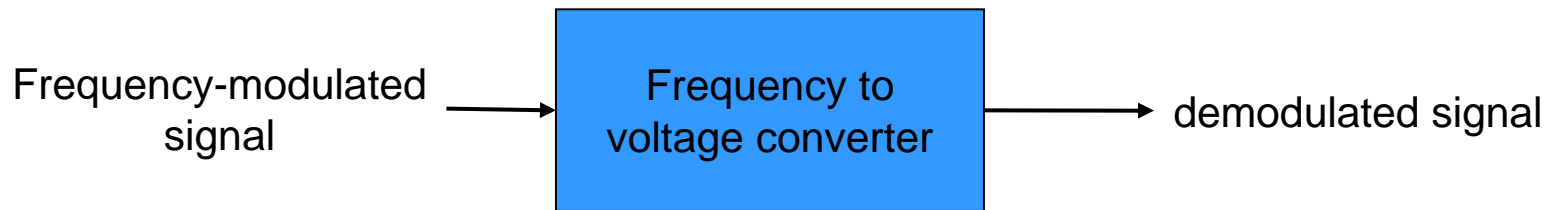

- Frequency Discriminator:

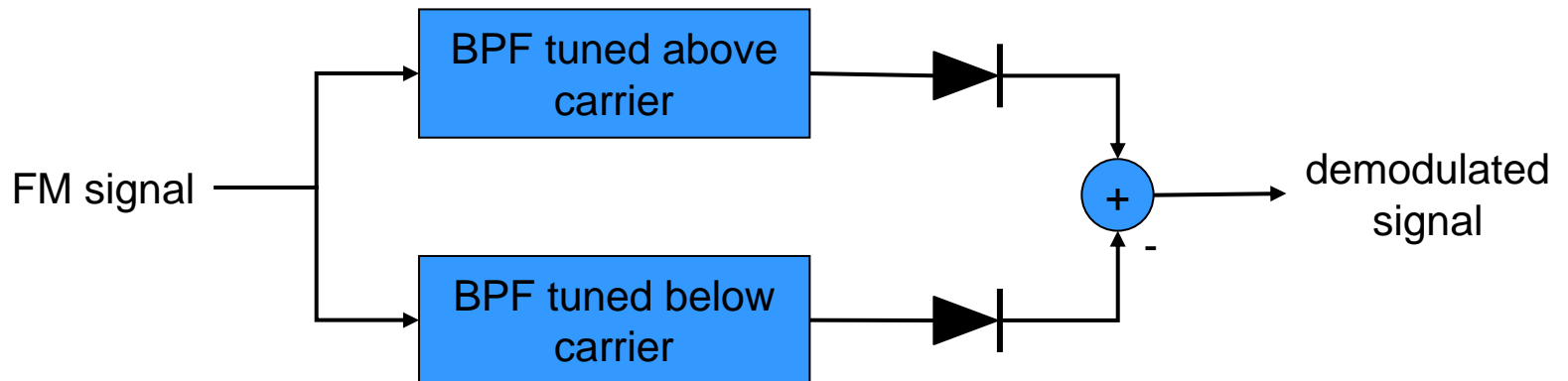

Digital Modulation

- As before, the generic expression for a modulated signal

$$m(t) = A_c [1 + m_A b(t)] \cos((w_c + m_f b(t))t + m_p b(t) + \phi_c)$$

- For digital modulation, $b(t)$ is a digital waveform – discrete in time and level:

$$b(t) = b(nT) \in \{l_1, l_2, \dots, l_m\}$$

- The modulated signal “shifts” between discrete states, so digital modulation techniques are referred to differently than analog modulation:

Analog	Digital
AM	Amplitude Shift Keying (ASK)
FM	Frequency Shift Keying (FSK)
PM	Phase Shift Keying (PSK)

M-ary signaling

- The size of the baseband signaling set may be binary:

$$b(t) = b(nT) \in \{l_1, l_2\} = \{0, 1\}$$

- Or M-ary

$$b(t) = b(nT) \in \{l_1, l_2, \dots, l_m\}$$

M-ary signaling

- The size of the baseband signaling set may be binary:

$$b(t) = b(nT) \in \{l_1, l_2\} = \{0, 1\}$$

- Or M-ary

$$b(t) = b(nT) \in \{l_1, l_2, \dots, l_m\}$$

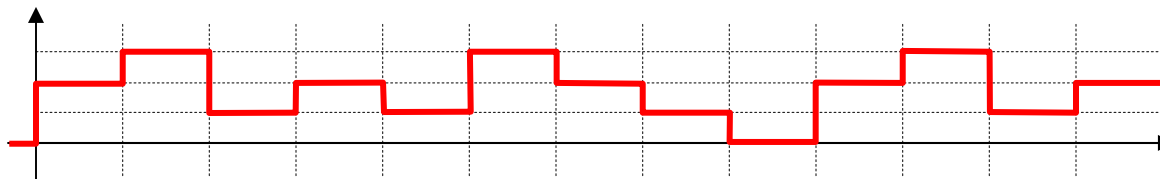
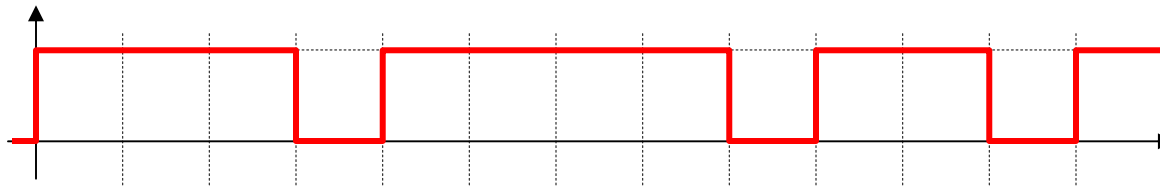

ASK

- Amplitude Shift Keying (ASK) = On-Off Keying (OOK) if the modulation is 100%

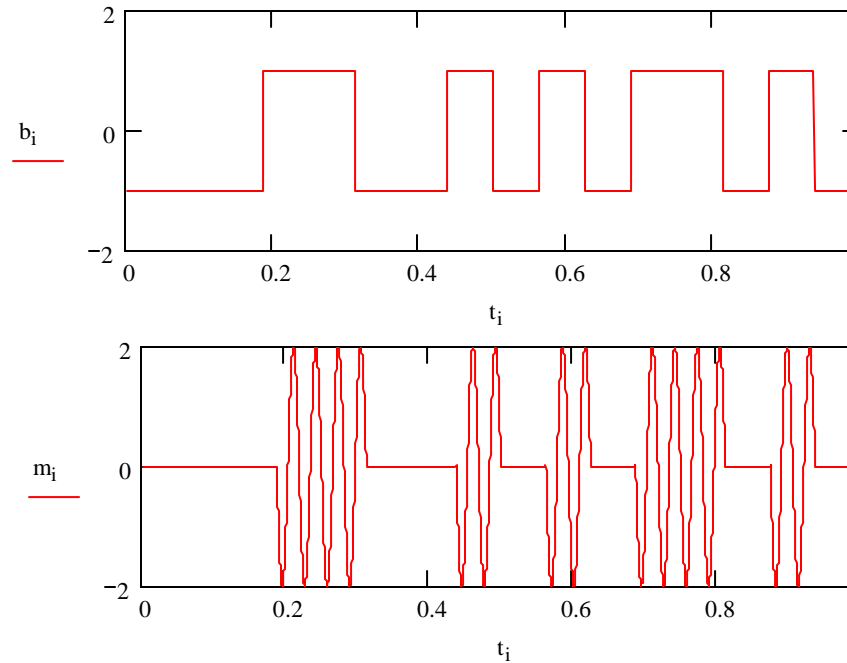

FSK

- FSK maintains the carrier magnitude

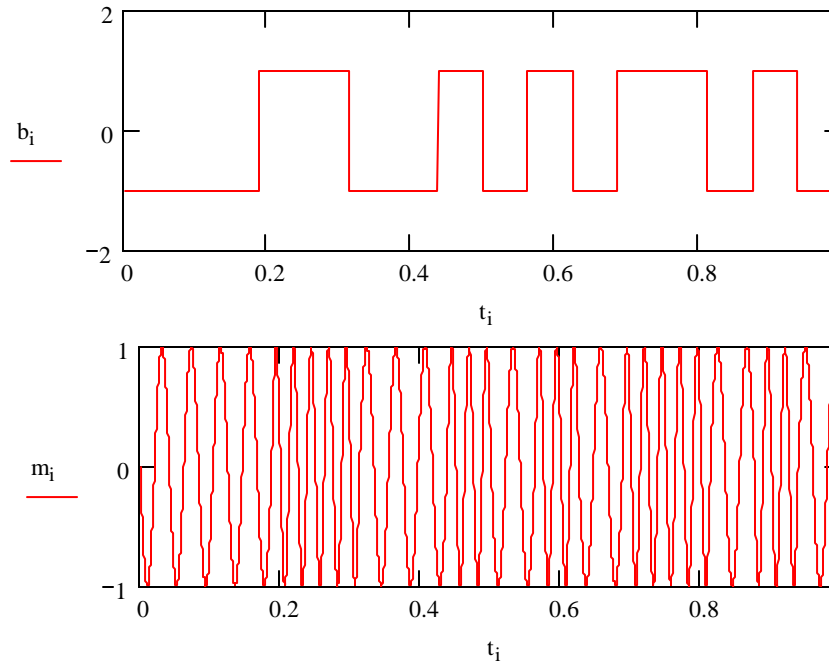

PSK

- PSK maintains the carrier amplitude and the average carrier frequency

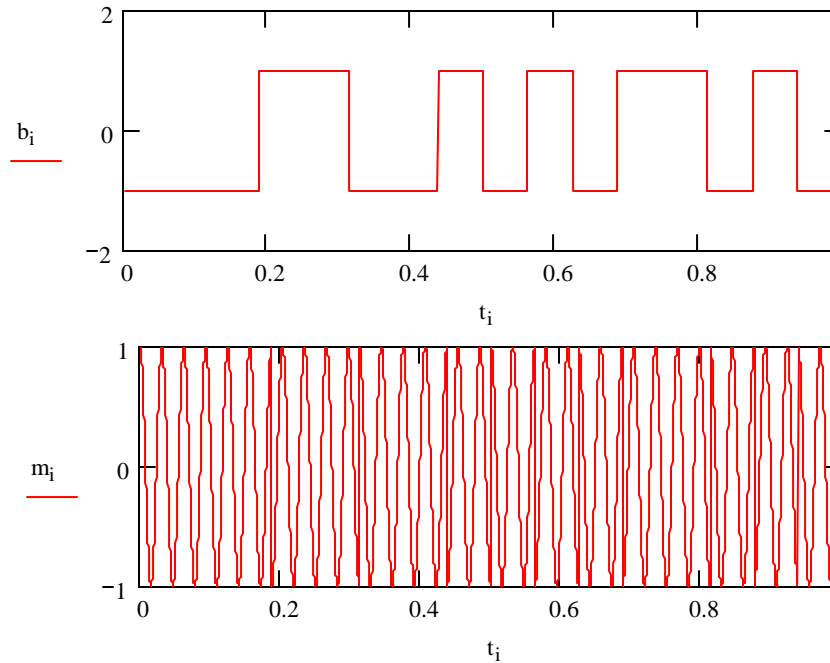

Phasor Representation of Modulated Signals

- Consider a coordinate system, rotating at the carrier frequency:

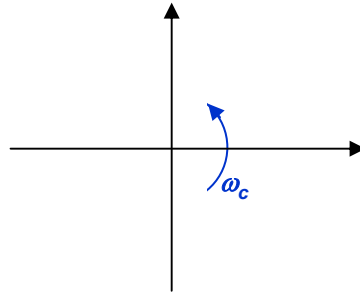

- All signal energy at or nearly related to the carrier frequency will be rotating at approximately the same speed.
 - In particular, consider the “on” and “off” periods of an ASK signal

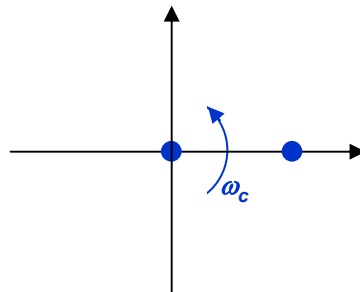

Phasor Representation of PSK Signals

- First, consider a binary PSK system (BPSK). The two transmit phases are chosen 180 degrees apart.

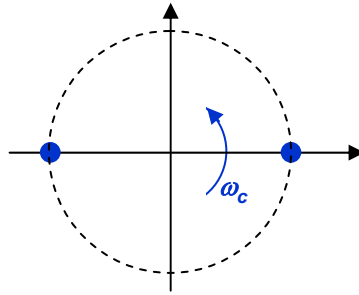

Phasor Representation of PSK Signals

- First, consider a binary PSK system (BPSK). The two transmit phases are chosen 180 degrees apart.

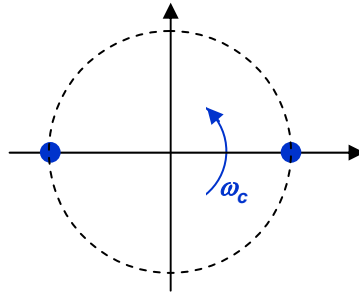

- Next, we can consider an m-ary PSK system, e.g., m=4

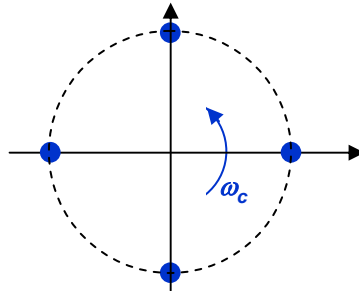

PSK and Quadrature Modulation

- Is this signal PSK or ASK?

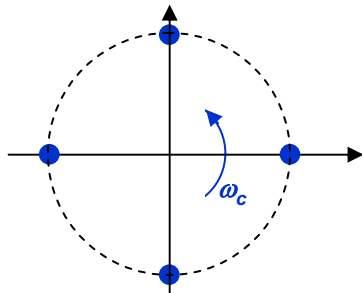

PSK and Quadrature Modulation

- Is this signal PSK or ASK?

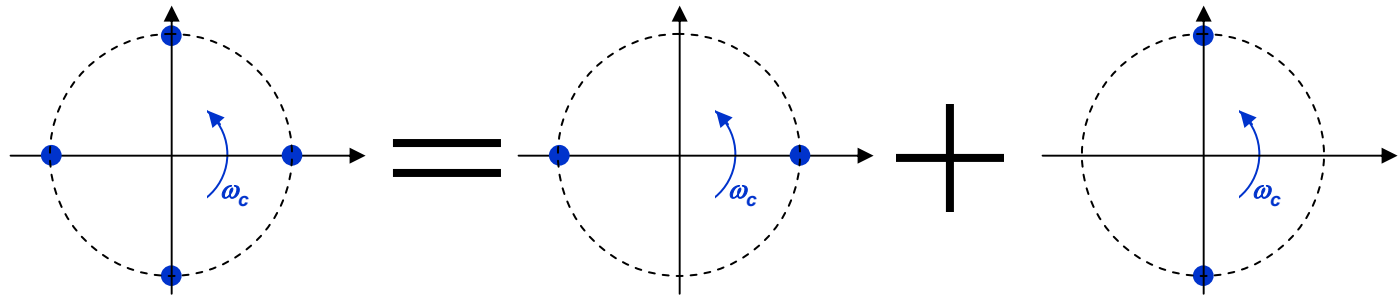

PSK and Quadrature Modulation

- Is this signal PSK or ASK?

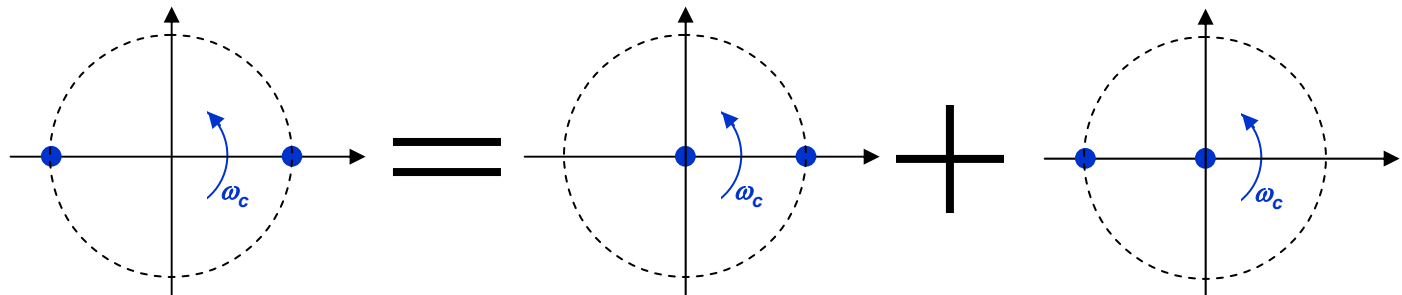
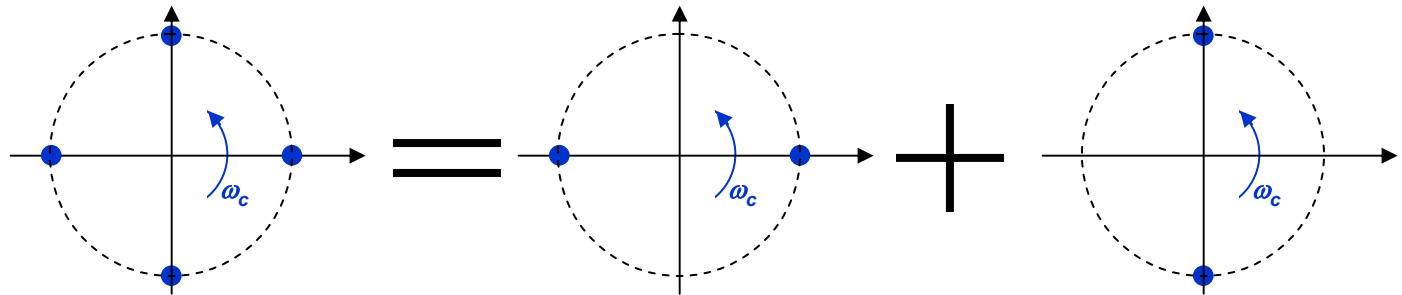

Signal Constellation Design

- A typical 16-QAM constellation:

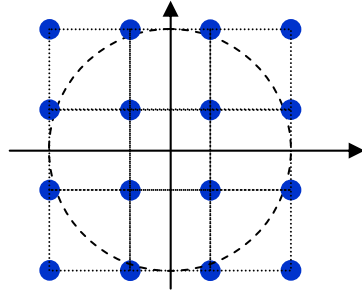

Filtering Considerations

- Simplest case for a communications system:

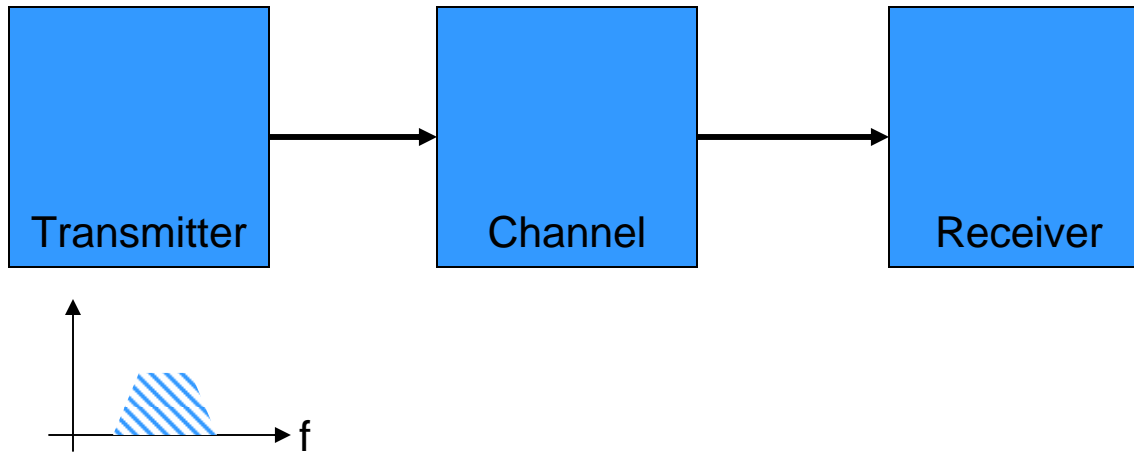

Filtering Considerations

- Simplest case for a communications system:

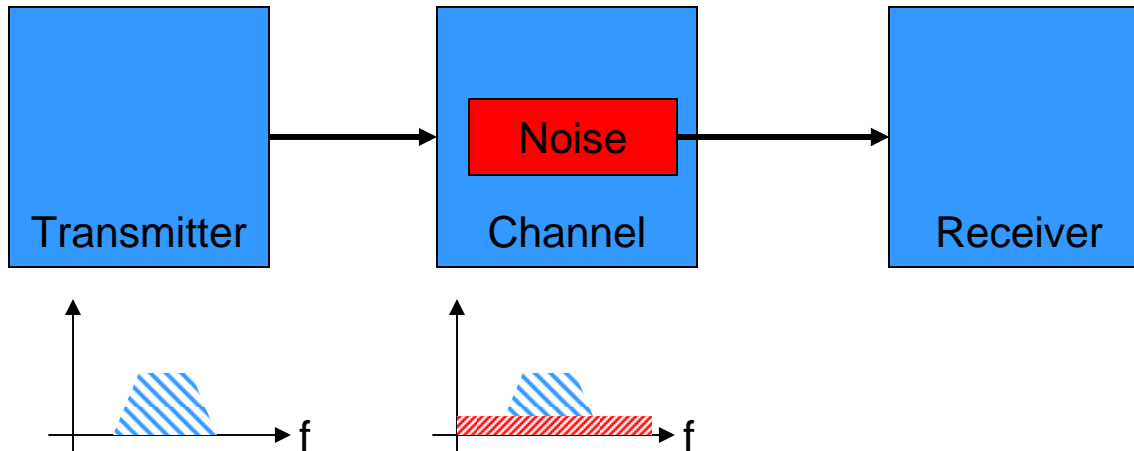

Filtering Considerations

- Simplest case for a communications system:

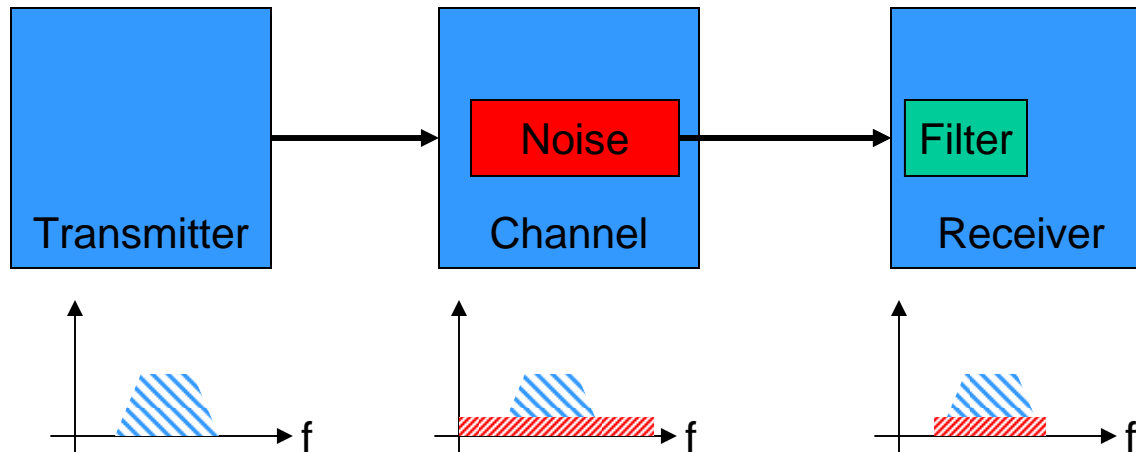

Filtering Considerations

- Simplest case for a communications system:

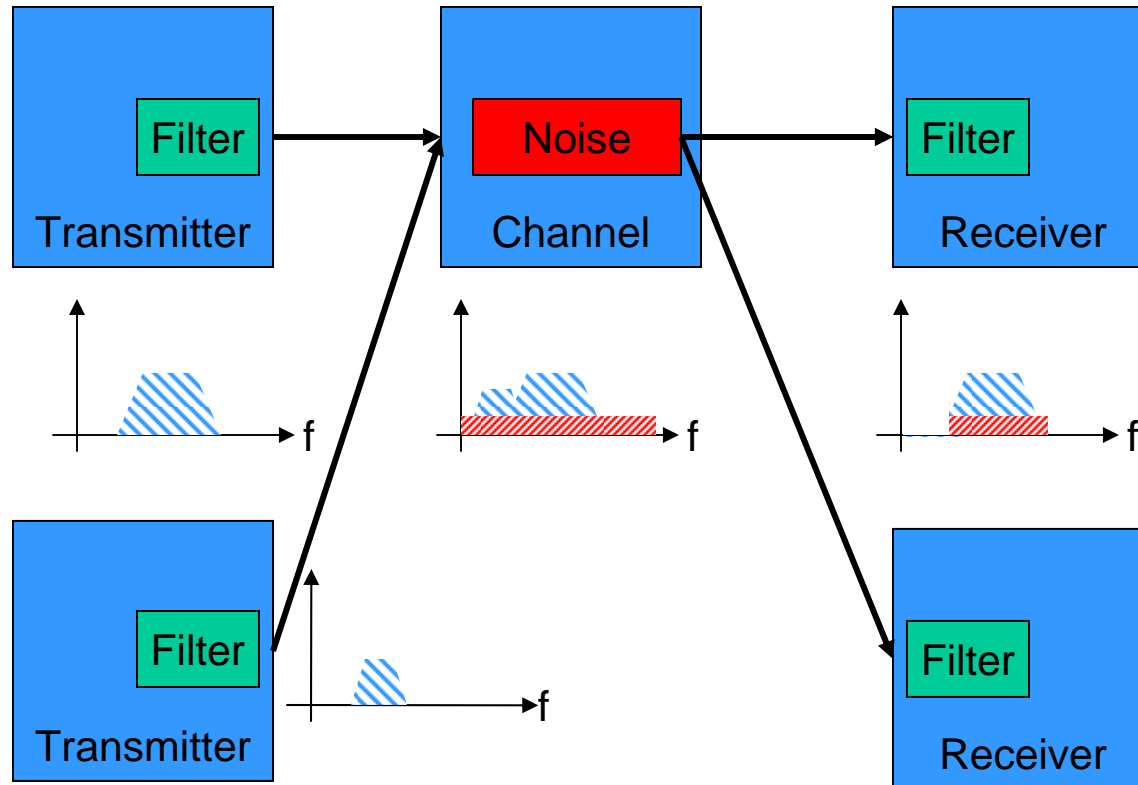

- More realistically, there are other users transmitting and receiving signals

More Filtering Considerations

- For the simplest form of modulation, BPSK, generate a random sequence

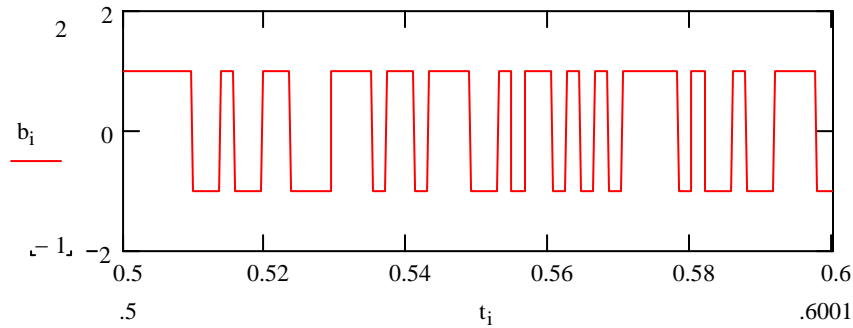

- And look at it in the frequency domain

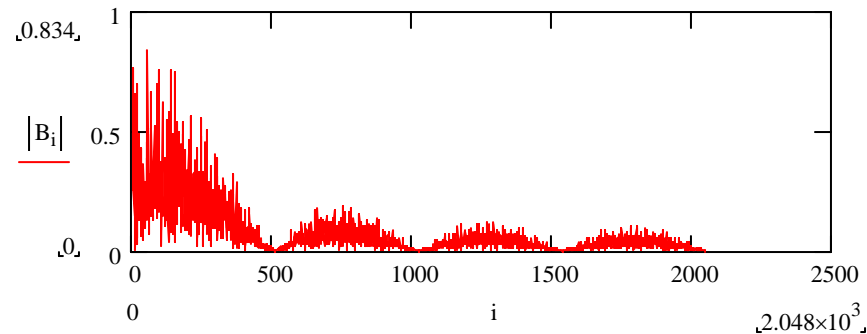

Filtering the Baseband signal

- In the time domain

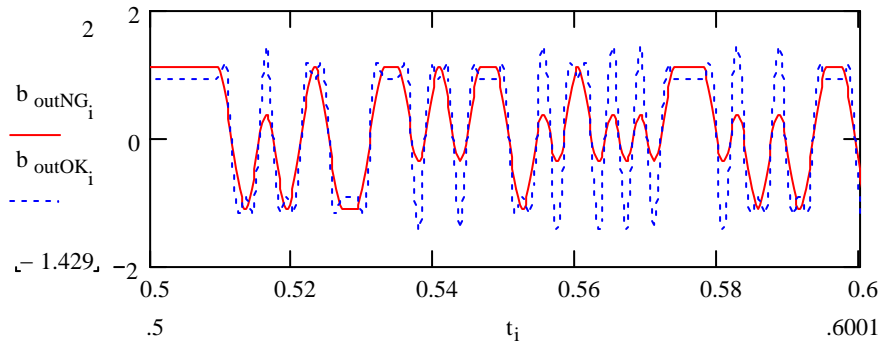

- In the frequency domain

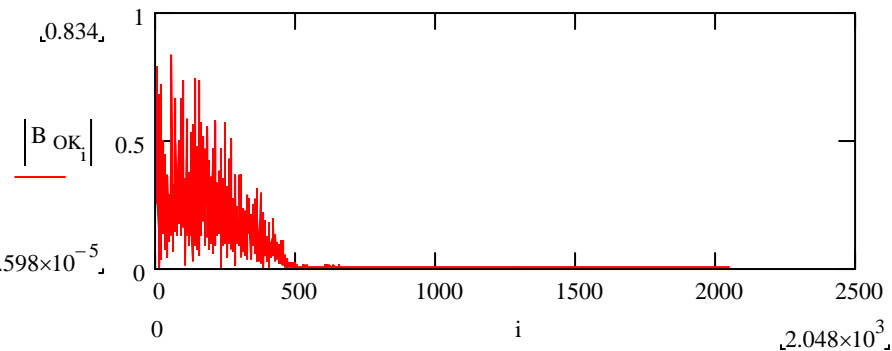
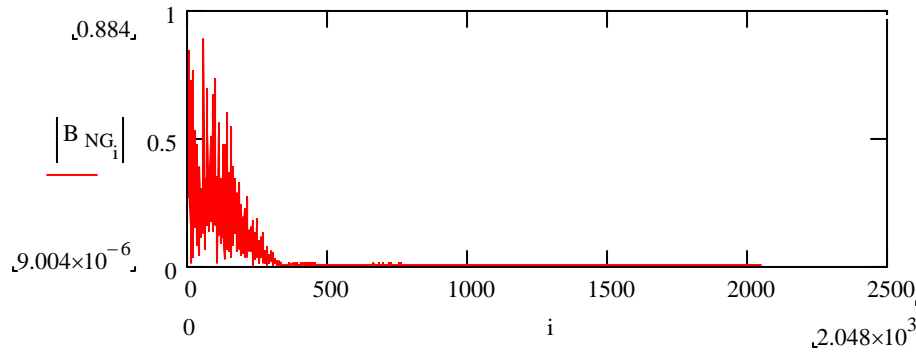

Examining the “Eye Diagram”

- Eye diagram for properly filtered signal
- Eye diagram for over-filtered signal

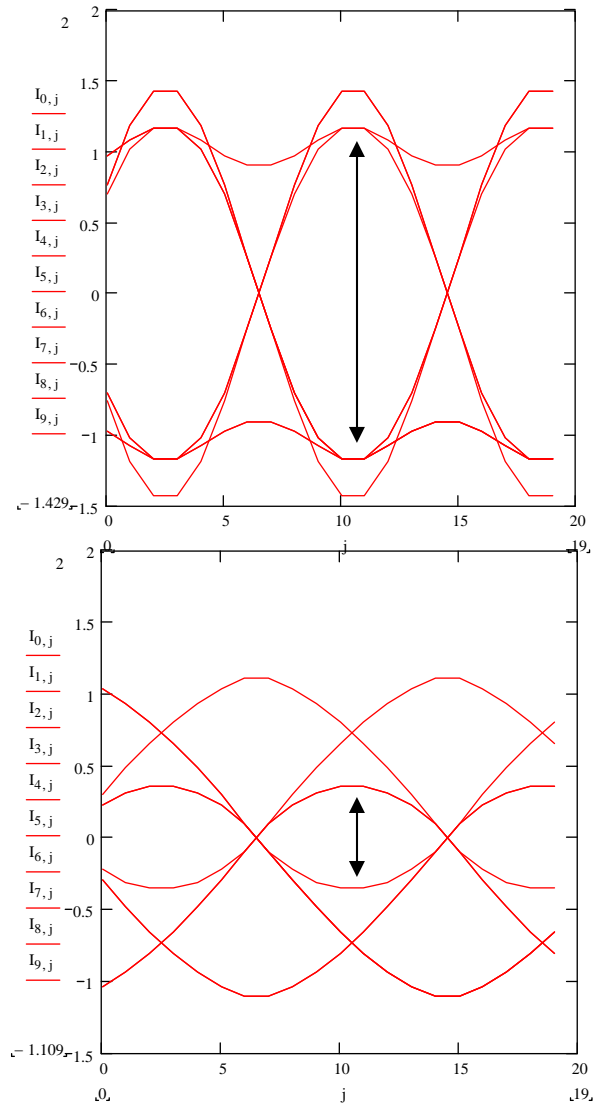

The Effect of ISI on the Eye Diagram

- A filter with no ISI

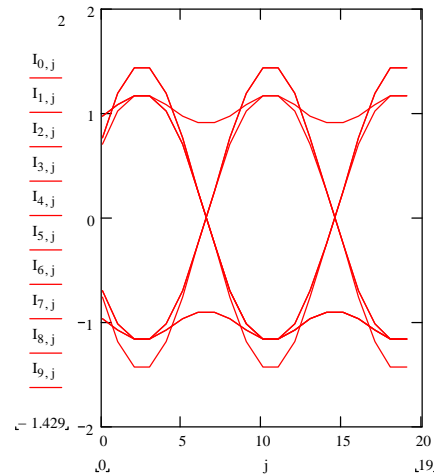

- ISI due to the filter dispersion

